

## SECTION 501

### DIVISION 500 - STRUCTURES

#### *SECTION 501 -- TEMPORARY BRIDGE*

##### **Description**

**1.1** This work shall consist of the design, furnishing or obtaining, construction, maintenance and removal of a temporary bridge(s) and, if specified, the approaches to the temporary bridge meeting the requirements shown on the plans or contained herein. The work shall also include the design and construction of temporary abutments and piers, as required, bridge rail, connection to portable concrete barrier or temporary guardrail, and furnishing all equipment to install and dismantle the temporary bridge. The limits of the available work area shall be as indicated on the plans or as permitted.

##### **Materials**

**2.1** All materials to be used in the construction of the temporary bridge shall be subject to inspection and approval by the Engineer prior to their incorporation into the work. Used material will be acceptable, provided appropriate allowances are made for their condition.

**2.1.1** Steel sheet piling shall conform to 506.

**2.1.2** Steel bearing piles shall conform to 510.

**2.1.3** Concrete shall conform to 520.

**2.1.4** Reinforcing steel shall conform to 544.

**2.1.5** Structural steel shall conform to 550.

**2.1.6** Structural timber shall conform to 568.

**2.1.7** Bridge rail shall be galvanized steel conforming to 563.2.

**2.2** The Contractor shall provide the temporary bridge incorporating one of the following sources:

(a) Modular Prefabricated Panel Bridge System – Contractor Supplied. Bridge components such as those manufactured by Acrow Corporation of America, Maybe Bridge, Inc., or equal subject to approval by the Department, Contractor supplied, purchased or leased under separate agreement.

(b) Site Specific Bridge – Contractor Supplied. Bridge components, such as structural steel members with concrete or steel decking, Contractor supplied and constructed.

##### **Construction Requirements**

**3.1** Unless otherwise specified on the Plans, the temporary bridge, including the rail system and substructures shall meet the minimum strength requirements of an HL-93 design loading and pedestrian loading as required and specified in the AASHTO "LRFD Bridge Design Specifications". The bridge,

including superstructure, rail system, and substructures shall be designed by a Licensed Professional Engineer.

**3.1.1** Detailed plans, showing sizes, arrangement, and quality of the materials to be used in the construction and calculations of the proposed temporary bridge shall be stamped with the seal of the Licensed Professional Engineer, signed and submitted for documentation to the Engineer in accordance with 105.02. Plans shall be documented and authorization to proceed with construction shall be obtained before construction is started. As provided 105.02, such documentation shall not relieve the Contractor from any responsibility under the Contract.

**3.1.2** When more than one Engineer is responsible for the design of separate components of the temporary bridge (i.e. substructure and superstructure), the Contractor shall make one submittal for documentation containing all portions of the temporary bridge unless otherwise allowed.

**3.2** The temporary bridge shall have a minimum clearspan length as shown on the plans. The minimum low steel elevation with provisions for any anticipated sag and dead load deflections shall be maintained as noted in the contract plans.

**3.3** The temporary bridge and approaches shall be designed to accommodate the free passage of vehicles, including snowplows, for either one-way, two-way, or pedestrian traffic as specified on the Plans. The bridge shall provide for a clear width as shown on the plans.

**3.4** All approach work shall be performed in accordance with the applicable specifications.

**3.5** No trees shall be removed without approval.

**3.6** For Modular Prefabricated Panel Bridge Systems, the Contractor shall submit, for approval, a detailed proposed sequence of erecting and dismantling of the bridge components. Plans shall be prepared by a Licensed Professional Engineer with the assistance of the manufacturer of the bridge system. Plans shall be approved before construction is started.

**3.6.1** The Contractor shall have a representative from the manufacturer of the bridge system present during the erection and dismantling of the bridge components.

**3.7** The Contractor shall maintain the temporary bridge until removal. The maintenance shall consist of weekly joint inspections by the Department and the Contractor as to the condition of the bridge and any repairs deemed necessary by the Engineer.

**3.8** If the Contractor elects to use an alternate bridge system at any time during the Contract, the alternate bridge system shall be in place and operational before removal of the existing temporary bridge system.

**3.9** When the temporary bridge and approaches are no longer required, they shall be completely removed and the area restored to its original condition or as shown on the Plans, or as directed.

### **Method of Measurement**

**4.1** Temporary bridge and temporary bridge including approaches of the type specified will each be measured as a unit. No separate measurement will be made for multiple structures required to provide the temporary bridge as required. When more than one unit is specified in the Contract, separate item numbers will appear for each separate and complete unit.

## SECTION 501

### 4.2 Measurement of Approach Work.

4.2.1 When Item 501.1, Temporary Bridge of the type specified, is used, specific items for the approach work will appear in the Contract and measurement of these items will be in accordance with their respective sections.

4.2.2 When Item 501.2, Temporary Bridge including Approaches of the type specified, is used, all temporary bridge approach work will be included in the unit measurement.

#### Basis of Payment

5.1 The accepted Temporary Bridge and Temporary Bridge including Approaches of the type specified will each be paid for at the contract lump sum price.

#### Pay items and units:

501.1	Temporary Bridge	Unit
501.11	Temporary Footbridge	Unit
501.2	Temporary Bridge including Approaches	Unit
501.21	Temporary Footbridge including Approaches	Unit

## SECTION 502 -- REMOVAL OF EXISTING BRIDGE STRUCTURE

### Description

1.1 This work shall consist of the removal and satisfactory disposal of the existing bridge structure as shown on the plans, except such portions thereof as may be required or permitted to be left in place, or portions designated for salvage.

### Construction Requirements

3.1 The Contractor shall dismantle the existing structure in any manner that will not cause damage to persons or property. Removal of those portions of the existing bridge over roadways, railroads, and waterways shall be accomplished with the least possible disruption of the normal traffic flow under the bridge. Special care and precautions, including protective structures as required or ordered, shall be taken to insure that no debris is allowed to fall on any roadway, railroad, or waterway.

3.1.1 Detailed plans showing the size, arrangement and quality of materials to be used in the removal of existing bridge structures and the construction of protective structures shall be submitted for documentation

3.1.2 or in accordance with 105.02. Plans shall show the proposed method(s) of removal, all required falsework, protective structures and equipment needed to safely accomplish the structure removal.

3.2 If it is specified that the existing structure, or any portion thereof, is to be salvaged, it shall be dismantled and removed in such a manner as to avoid damage to any member thereof. All structural steel members shall be marked with paint indicating member size and grade of steel.

## SECTION 502

**3.2.1** If it is specified that any part or parts of the existing structure are to be salvaged for re-erection, all members shall be match-marked with paint before they are dismantled. All pins, bolts, nuts, loose plates, and the like shall be appropriately marked for identification and be placed in durable containers. Salvaged materials shall be stored in neat piles within the limits of the right-of-way adjacent to the work or loaded onto trucks as directed.

**3.3** All parts not designated for salvage on the plans or in the special provisions shall become the property of the Contractor and shall be satisfactorily disposed of by the Contractor.

### Method of Measurement

**4.1** This item will be measured as a unit. When more than one unit is specified in the Contract, separate item numbers will appear for each separate and complete unit.

**4.2** Limits of work shall be as established on the plans either by detail or by note. Unless otherwise shown, the horizontal limits will not exceed the neat lines of the portion of the structure to be removed.

**4.2.1** Unless otherwise shown on the plans, when the horizontal limits of bridge excavation, roadway excavation, or channel excavation fall within the specified removal limits of existing abutments, wingwalls or piers, the removal of the substructure material will be paid under the governing excavation item. Only portions of the existing bridge substructure which fall outside the horizontal limits of all other excavation items will be included as part of this item.

### Basis of Payment

**5.1** The accepted removal of existing bridge structure will be paid for at the contract lump sum price.

**5.1.1** Protective structures, if required or ordered, will be subsidiary.

#### Pay item and unit:

502	Removal of Existing Bridge Structure	Unit
-----	--------------------------------------	------

## SECTION 503 -- COFFERDAMS AND WATER DIVERSION STRUCTURES

### Description

**1.1** This work shall consist of the design, construction, maintenance, and removal of all cofferdams, caissons, cribs, sheeting, embankments, channel diversion structures, pipes, and other similar work, including dewatering, required to allow the excavation for foundation units and to permit and protect the construction of bridge or other structural units.

### Materials

**2.1** All materials to be used in the construction of this work shall be subject to inspection and approval prior to their incorporation in the structure.

**2.2** Sheeting specified to be left in place shall meet the requirements of 506.2.

## SECTION 503

### Construction Requirements

#### 3.1 General.

**3.1.1** Cofferdams and water diversion structures shall be constructed so as to protect fresh concrete against damage from a sudden rising of the stream and to prevent damage to the footings and bridge units by erosion.

**3.1.2** The Contractor shall submit drawings showing materials to be used, proposed method of construction, and other details left open to choice or not fully shown on the plans. When cofferdams are required or proposed, such information shall show the arrangement for flooding the cofferdam. Drawings shall be submitted for documentation in accordance with 105.02.

#### 3.2 Water Diversion Structures.

**3.2.1** Temporary diversion channels, dikes, embankments and other similar structures shall be constructed in a way to minimize erosion and resulting water pollution. Appropriate measures of protection shall be incorporated into their construction.

**3.2.2** Pipes, sluices, elbows, etc. that are used in the diversion of water shall be of sufficient size to carry the flow specified on the plans.

**3.2.3** Temporary diversion channels, dikes and embankments shall be completely removed and restored to original or design grades as directed by the Engineer.

#### 3.3 Cofferdams.

**3.3.1** Cofferdams or cribs for foundation construction shall be carried to adequate depths and heights, shall be safely designed and constructed, and shall be as watertight as necessary for the proper performance of the work which must be done inside them. Interior dimensions shall be such as to give sufficient clearance for the construction and exterior inspection of forms and to permit pumping outside of the forms. In no case shall the sheeting be placed inside the neat lines shown for the concrete footing or seal. No construction material shall be left in cofferdams in such a way as to extend into the substructure masonry, without permission.

**3.3.2** No excavation shall be made outside of cofferdams, nor shall the existing streambed adjacent to the structure be disturbed without the approval of the Engineer. When the Contractor is permitted to make excavation at the site of the structure before cofferdams are placed, all openings outside the cofferdams shall be backfilled with approved material to the elevations of the original ground or streambed after the cofferdams have been placed.

**3.3.3** Cofferdams which are tilted or moved laterally during the process of sinking shall be righted, reset, or enlarged, so as to provide the necessary clearance, at the Contractor's expense.

**3.3.4** Unless otherwise provided, cofferdams including all bracing shall be removed by the Contractor after the completion of the substructure, with care being taken not to disturb the surrounding soil or injure the finished masonry.

**3.3.5** Concrete foundation seals, when required or permitted, shall be constructed as provided in 520.

**3.3.6 Cofferdams with sheeting left in place.** When called for on the plans, cofferdam sheeting shall be cut off at the top of the foundation seal or footing or at the specified elevation. The length of

sheeting left in place below the specified cut off elevation will be the minimum embedment length shown on the plans or the length required on the approved cofferdam design drawings.

**3.3.6.1** Anchorage between the cofferdam sheeting and concrete foundation, if required, will be detailed on the plans.

**3.4 Dewatering.** Control of water within cofferdams shall be in such a manner as to prevent disturbance of the bearing soil, or fresh concrete, or segregation of backfill material. Pumping areas shall be properly filtered to prevent pumping of fines.

**3.4.1** No pumping shall be permitted during the placing of concrete or for a period of at least 24 hours thereafter, unless it is done from a suitable sump separated from the concrete work by a watertight wall.

**3.4.2** Pumping to dewater a cofferdam with a concrete foundation seal shall not commence until the seal has set sufficiently to withstand the hydrostatic pressure, and in no case before 5 days have elapsed following the placing of the concrete.

**3.4.3** Any foundation soil weakened as a result of insufficient care taken in maintaining a dewatered condition shall be removed and replaced with structural fill at the expense of the Contractor.

#### **Method of Measurement**

**4.1** The accepted quantity of water diversion structures, cofferdams, and cofferdams with sheeting left in place will each be measured as a unit. When more than one unit is specified in the Contract, separate item numbers will appear for each separate and complete unit.

#### **Basis of Payment**

**5.1** The accepted quantity of water diversion structures, cofferdams, and cofferdams with sheeting left in place will be paid for at the contract lump sum price. The cost of any required anchorages shall be subsidiary.

**5.2** When no quantities for these items are included in the proposal, the work shall be subsidiary except as may be provided under 5.3.

#### **5.3 Alterations.**

**5.3.1** When the foundation is to be placed on earth, the cost of necessary alterations to the cofferdams due to required changes of more than 1 ft (300 mm) in depth of the bridge excavation will be paid for as provided for in 109.04.

**5.3.2** When the foundation is to set on existing rock as prepared in accordance with 504.3.2, the cost of necessary alterations to the cofferdams when existing rock is encountered at an elevation more than 5 ft (1.5 m) below that anticipated at the time of the proposal will be paid for as provided for in 109.04. In cases where the plans show a sloping rock surface, no extra payment will be made unless the depth to rock is more than 5 ft (1.5 m) below the lowest elevation shown. When extra work is ordered, the cost of the first 5 ft (1.5 m) of additional depth of the cofferdam will not be included in the extra work payment. If rock is ordered removed in addition to that required by 504.3.2, the cost of any necessary alterations to the cofferdams resulting from such rock removal will be paid for as extra work.

## SECTION 503

### Pay items and units:

503.1	Water Diversion Structures	Unit
503.2	Cofferdams	Unit
503.3	Cofferdams with Sheeting Left in Place	Unit

## SECTION 504 -- BRIDGE EXCAVATION

### Description

**1.1** This work shall consist of the excavation, satisfactory disposal, and backfill of all materials encountered in the construction of bridges as shown on the plans or ordered.

### Classification of Materials

**2.1** Common bridge excavation shall consist of all materials not classified as rock. Glacial till or boulder clay will be considered as common bridge excavation.

**2.2** Rock bridge excavation shall consist of solid rock which cannot be removed without blasting or ripping. It shall also consist of boulders and parts of masonry structures when found to measure 1/2 yd<sup>3</sup> (0.5 m<sup>3</sup>) or more.

### Construction Requirements

#### 3.1 Preparation of a Foundation on Earth.

**3.1.1** In areas of excavation where pumping is not required, material shall be removed and maintained a minimum of 1 ft (300 mm) outside the neat lines of the footing.

**3.1.2** In areas of excavation where pumping is required, material shall be removed and maintained to such limits as will provide for carrying water outside all footing forms, with the water level maintained slightly lower than the elevation of the bottom of all footings. Suitable sumps shall be constructed and maintained.

**3.1.2.1** Where materials are encountered which are susceptible to softening or displacement when inundated, pumping shall begin prior to removal of material to grade and shall continue on a 24-hour basis until masonry has been placed.

**3.2.1.1** When blasting is required, the provisions of 203.3.2 shall apply as though contained in this Section.

**3.1.3** The final removal of the foundation material to grade shall be made in such a manner that the foundation material below grade will not be disturbed or loosened and a uniform foundation will be obtained. Removal shall be made by hand unless the use of power equipment for this purpose performs satisfactorily. This portion of the excavation shall be made in as short a time as possible before the masonry is to be placed.

**3.1.4** When ordered, a layer of structural fill of sufficient depth to stabilize the foundation material shall be applied prior to placing either forms, reinforcing steel, or masonry.

### **3.2 Preparation of a Foundation on Rock.**

**3.2.1** Care shall be taken to avoid undue overbreakage in the drilling and blasting of rock.

**3.2.1.1** When blasting is required, the provisions 203.3.2 shall apply as though contained in this Section.

**3.2.2** The surfaces to receive the footings shall be level, stepped, roughened, doweled, or any combination thereof as directed. When the use of dowels is ordered, holes shall be drilled to the depth required and the dowels grouted with cement mortar conforming to 707. The surfaces shall be cleaned and maintained clean until the masonry is placed.

**3.2.3** All loose rock and fragments shall be removed as directed.

**3.2.4** Seams shall be cleaned and grouted when ordered.

**3.3 Inspection.** After each excavation is completed, and prior to placing forms for concrete, the Contractor shall secure approval of the depth of excavation and the character of the foundation material.

### **3.4 Backfill.**

**3.4.1** Where masonry is to rest on a rock surface, all space resulting from excavating rock within vertical planes through the neat lines of the footings shall be backfilled with concrete of the same class as that in the footings, unless otherwise shown or ordered.

**3.4.2** All spaces resulting from excavation adjacent to the structure shall be backfilled to the level of the surrounding ground with suitable material from the excavation, free from rock, lumps, wood, or other foreign matter, unless otherwise shown or ordered.

**3.4.3** Backfilling around footings shall be done immediately after form removal. Backfilling adjacent to and over arch rings or rigid frame structures shall not be performed until 21 days after the concrete has been placed, or the test cylinders prepared from the fresh concrete and cured in the laboratory have attained 80 percent of the minimum compressive strength of the class of concrete shown on the plans. Backfill material shall not exceed the optimum moisture content by more than 2 percentage points. The material shall be placed in layers not more than 12 in (300 mm) loose depth and compacted. To avoid unequal pressures, the material shall be placed and compacted evenly on both sides of arches and other frame type structures. All required material shall be placed in front of walls and abutments prior to beginning fills behind these structures. Unless otherwise permitted, backfilling behind bridge abutments shall be made to the elevation of the bridge seat before the structural steel is erected. Mechanical tamping or vibrating devices must be used where the use of rollers and the like are impracticable.

**3.4.4** Density requirements shall conform to 203.3.8.

**3.4.5** Adequate drainage shall be provided at all times. Water shall be used only in sufficient amounts to obtain the required compaction. Under abnormal conditions where there is no possibility of developing a liquid pressure on the structure and it is impossible or difficult to use power tamping or vibrating devices, the Engineer may order the use of water in such amounts as may be necessary to assist in placing and compacting the backfill.

## SECTION 504

**3.5 Approaches.** When the plans for a bridge or culvert structure require the construction of an approach, the fill shall be constructed in accordance with 203.3.7.

**3.6 Cofferdams.** When the work prescribed in 503 is subsidiary, the construction methods included in 503 shall apply as though contained herein.

### Method of Measurement

**4.1** Common bridge excavation will not be measured, but shall be the cubic yard (cubic meter) final pay quantity in accordance with 109.11. Rock bridge excavation will be measured by the cubic yard (cubic meter) within the following limits:

**4.1.1** The upper limit will be the original ground except as provided under 203.5.1.6.

**4.1.2** The lateral limits shall be vertical planes, 1 ft (300 mm) outside the neat lines of the footings and parallel thereto unless otherwise noted.

**4.1.2.1** When bridge excavation is required in order to place portions of the structure outside of the lateral excavation limits specified above, as may be the case in beams and cantilever walls, payment planes will be parallel to the structure, 1 ft (300 mm) away from the structure, measured normally.

**4.1.3** The lower limits shall be as follows:

**4.1.3.1** When excavation for masonry that is to rest on a surface other than rock is required down to a depth of 1 ft (300 mm) below the elevations shown on the plans, the material actually removed to such 1 ft (300 mm) depth will be measured for payment. When such excavation is required deeper than 1 ft (300 mm) below the elevations shown on the plans, the quantity of all excavation required below such limit will be paid for at 150 percent of the bid price of the appropriate bridge excavation.

**4.1.3.2** Unless otherwise shown on the plans, when masonry is to rest on existing rock either undisturbed or prepared in accordance with 3.2, the lower limit shall be either the surface of the existing undisturbed rock or the firm surface prepared in accordance with 3.2, but any rock removed below an elevation 1 ft (300 mm) lower than the required elevation will be considered as excess removal and will not be measured. The quantity of any common excavation removed more than 1 ft (300 mm) below the assumed elevation of the existing rock shown on the plans will be paid for at 150 percent of the bid price of the appropriate bridge excavation.

**4.1.3.3** Unless otherwise shown on the plans, when the masonry is to rest on a foundation at a plan elevation within rock, all material actually removed above a plane 1 ft (300 mm) below the plan elevation will be measured for payment. When such excavation is required and ordered deeper than 1 ft (300 mm) below the plan elevation, the quantity of all excavation below such limit will be paid for at 150 percent of the bid price of the appropriate bridge excavation. But any rock removed that was not ordered, below an elevation 1 ft (300 mm) lower than the required elevation will be considered excess removal and will not be measured.

**4.2** Material removed from existing structures will be considered as bridge excavation if it is not to be paid for under 502, and is either:

- (a) Removed from within the volume limits noted above, or;
- (b) Is outside these volume limits and is removed within a limit of 1 ft (300 mm) below the proposed slope or subgrade elevations or to such elevations as are noted on the plans or ordered.

## SECTION 504

**4.3** Blast vibration control and monitoring, preblast condition surveys, postblast surveys, blasting precautions and other protective measures will not be measured.

**4.4** When both classes (common and rock) are present in the bridge excavation the final pay quantity of common bridge excavation will be adjusted by the difference between the estimated and accepted quantity of rock bridge excavation.

### **Basis of Payment**

**5.1** Common bridge excavation is a final pay quantity item and will be paid for at the contract unit price per cubic yard (cubic meter) in accordance with 109.11. The accepted quantity of rock bridge excavation will be paid for at the contract unit price per cubic yard (cubic meter).

**5.1.1** No payment will be made for unauthorized material removed except that actual overbreakage of rock will be paid for, not to exceed 1 ft (300 mm) below the elevations shown or ordered, within the same lateral limits specified in 4.1.2.

**5.2** Concrete necessary to replace material classified as excess removal will not be paid for; other concrete within the neat lines will be paid for under 520.

**5.3** Payment for drilling dowel holes ordered and cleaning and grouting seams will be made under extra work; the dowels will be paid for under 544.

**5.4** Structural fill ordered under 3.1.4 will be paid for under 508.

**5.5** When common bridge excavation is the only class included in the Contract, any rock bridge encountered will be paid for at 5 times the Contract unit price for the common bridge excavation under Item 504.2.

**5.6** The cost of all blast vibration control and monitoring, preblast condition surveys, postblast surveys, blasting precautions and other protective measures necessary to prevent damage and subsequent creation of claims in connection with blasting shall be subsidiary to Item 504.2.

### **Pay items and units:**

504.1	Common Bridge Excavation (F)	Cubic Yard (Cubic Meter)
504.2	Rock Bridge Excavation	Cubic Yard (Cubic Meter)

## **SECTION 506 -- SHEET PILING**

### **Description**

**1.1** This work shall consist of furnishing and placing permanent timber or steel sheet piling as shown on the plans or ordered.

### **Materials**

**2.1 Steel sheet piling.** The steel sheet piling shall conform to AASHTO M 202/M 202M (ASTM A 328/A 328M). Used steel sheet piling in good condition as determined by the Department is acceptable.

## SECTION 506

### Construction Requirements

#### 3.1 Steel Sheet Piling.

3.1.1 The sections when assembled in place shall be practically watertight at the joints.

3.1.2 The tops of the piles shall be cut off to a straight line at the elevation indicated.

3.2 **Defective piles.** The procedure incident to the driving of piles shall not subject them to excessive and undue abuse producing deformation of the steel. Manipulation of piles to force them into proper position, considered by the Engineer to be excessive, will not be permitted. Any pile damaged by reason of internal defects or by improper driving, driven out of its proper location, or driven below the elevation fixed by the plans or by the Engineer shall be corrected at the Contractor's expense.

### Method of Measurement

4.1 Steel sheet piling will be measured by the pound (kilogram).

4.2 Only the lengths shown on the plans or ordered will be measured.

### Basis of Payment

5.1 The accepted quantity of piling will be paid for at the contract unit price per pound (kilogram) for steel piling, as measured.

#### Pay items and units:

506.2	Steel Sheet Piling	Pound (Kilogram)
-------	--------------------	------------------

## *SECTION 508 -- STRUCTURAL FILL*

### Description

1.1 This work shall consist of the formation of embankments which are intended to support structures.

### Materials

2.1 Structural fill shall consist of crushed gravel unless bank-run gravel, clean stone fill, or other material is specified on the plans or permitted by the Engineer. When not otherwise limited the word gravel as used below will refer to both bank-run gravel and crushed gravel.

**2.1.1 Crushed Gravel for Structural Fill.****2.1.1.1 Required Grading:**

Sieve Size	Percentage by Weight Passing
3 in (75 mm)	100
2 in (50 mm)	95 - 100
1 in (25.0 mm)	55 - 85
No. 4 (4.75 mm)	27 - 52
No. 200 (0.075 mm)	0 - 12
(Based on the fraction passing the No. 4 (4.75 mm) sieve)	

**2.1.1.2** At least 50 percent by weight of the materials retained on the 1 in (25.0 mm) sieve shall have a fractured face.

**2.1.2 Bank-run Gravel for Structural Fill.** Bank-run gravel shall be graded as follows: 25 to 70 percent shall pass a No. 4 (4.75 mm) sieve. Not more than 15 percent of the portion which passes the No. 4 (4.75 mm) sieve shall pass a No. 200 (0.075 mm) sieve. No stone shall be included which cannot be incorporated in a 6 in (150 mm) - course.

**2.1.3 Clean Stone Fill for Structural Fill.****2.1.3.1 Required Grading:**

Sieve Size	Percentage by Weight Passing
2 in (50 mm)	100
1-1/2 in (37.5 mm)	95 - 100
3/4 in (19.0 mm)	35 - 70
3/8 in (9.5 mm)	10 - 30
No. 4 (4.75 mm)	0 - 5

**2.1.3.2** At least 50 percent by weight of the materials retained on the 3/4 in (19.0 mm) sieve shall have a fractured face.

**2.1.4 Wear.** The percent of wear of gravel or clean stone fill shall not exceed 50 percent as determined in accordance with AASHTO T 96.

**2.2** Concrete class F, flowable fill may be requested in writing as a substitute for structural fill. Approval in the form of a supplementary agreement shall be in consideration of, but not limited to, differential frost heaving due to dissimilar materials, unit weight, structural requirements, lack of permeability, and damming resulting from water flow cut off.

**Construction Requirements**

**3.1** The area upon which the fill is to be constructed, regardless of the height of the proposed fill, shall be stripped of all loam, refuse, roots, stumps, boulders, and the like and shall be backfilled with the same type of material as that found at the site. All excavation shown on the plans or ordered shall be completed before constructing the fill. When fills are to be made on hillsides or when fill is built one half

## SECTION 508

width at a time, the slopes of the original hillside or new fill shall be cut into or terraced as the work is brought up in layers.

**3.1.1** Before the first layer of structural fill is placed, the entire work area of the original ground shall be compacted with approved compacting equipment.

**3.2** Structural fill to be placed adjacent to new embankment material shall be placed concurrently with the embankment material to obtain lateral support.

**3.3** The fill shall be placed in horizontal layers of uniform thickness not exceeding 8 in (200 mm) loose depth and compacted to the required density prior to placing the next layer. Each layer shall be compacted with power rollers, power tampers or vibratory compactors until the required density is obtained. The surface of the fill shall be kept approximately level at all times and the portion of the fill to be occupied by the structure shall be maintained at the proper density by moistening and tamping if necessary, until the concrete or structure is in place.

**3.4** The density of structural fill will be determined by AASHTO T 191 (Sand Cone Method), or by AASHTO T 238 and T 239 (Nuclear Method) and shall be not less than 98 percent of the maximum density determined in accordance with AASHTO T 99 (Standard Proctor Test). This maximum density may also be determined by the control strip procedure in 304.3.8.

**3.5** The Contractor shall notify the Engineer of the anticipated date of completion of the structural fill at least 3 working days prior to completion of the fill. Upon completion, the Contractor shall not proceed with any further operations on the fill until the Engineer has taken all of the necessary proof borings. When approval has been given, the Contractor shall backfill any drilled holes with saturated sand or other approved material.

**3.6** The use of clean 1-1/2 in (38 mm) stone fill as structural fill may be permitted by the Engineer under special circumstances, such as when dewatering problems occur during foundation construction. The total thickness of stone fill shall not exceed 12 in (300 mm). All compaction and density requirements of this specification shall apply when using stone fill.

### Method of Measurement

**4.1** Structural fill will be measured by the cubic yard (cubic meter) as determined from the ground elevation immediately before the placement of any fill and the neat lines for the compacted material as shown on the plans.

### Basis of Payment

**5.1** The accepted quantity of structural fill will be paid for at the contract price per cubic yard (cubic meter) complete in place.

**5.1.1** Concrete class F, flowable fill substituted for structural fill will be paid for at the contract unit price for structural fill.

**5.2** Excavation in preparation for this item will be paid for under 504 unless otherwise indicated on the plans. Any excavation for terracing and any backfilling of proof boring holes will not be measured but will be incidental to the work.

#### Pay item and unit:

508	Structural Fill	Cubic Yard (Cubic Meter)
-----	-----------------	--------------------------

**SECTION 510 -- BEARING PILES**

DESCRIPTION	205
MATERIALS AND EQUIPMENT .....	205
2.1 MATERIALS .....	205
2.2 EQUIPMENT FOR DRIVING PILES. ....	206
CONSTRUCTION REQUIREMENTS	212
3.1 GENERAL .....	212
3.2 PILES. ....	213
3.3 DETERMINATION OF PILE DRIVING CRITERIA. ....	215
3.4 PILE LOAD TESTS. ....	216
3.5 REQUIRED ULTIMATE RESISTANCE. ....	218
3.6 PREPARATION AND DRIVING.....	218
3.7 CUTTING OFF PILES .....	220
METHOD OF MEASUREMENT	220
BASIS OF PAYMENT	221

**Description**

**1.1 General.** This work shall consist of furnishing all types of bearing piles, furnishing pile driving equipment, and driving bearing piles to the required penetration, and when required, test loading, splicing, and cutting, as shown on the plans or ordered.

**Materials & Equipment****2.1 Materials**

**2.1.1** Concrete piles, precast or cast-in-place, shall be Class A unless otherwise shown on the plans and shall conform to 520. All concrete for cast-in-place piles shall be designed with the necessary admixtures to maintain the required slump and sufficient workability throughout the entire concrete placement operation. Reinforcing steel shall conform to 544.

**2.1.2 Steel Piles.**

**2.1.2.1** Steel H-piles shall conform to the general requirements for rolled steel plates, shapes, sheet piling and bars for structural use, AASHTO M 160/ 160 M (ASTM A 6/A 6M).

**2.1.2.2** Unless otherwise specified, high-strength, low-alloy steel shall be furnished for all H-piles and conform to AASHTO N270/M270M (ASTM A709/A709M).

**2.1.2.3** Steel pipe piles shall conform to ASTM A 252, Grade 2, unless otherwise specified.

**2.1.2.4** The use of foreign steel will be permitted only after approval by the Engineer upon suitable certification from a recognized domestic laboratory.

**2.1.3** Driving points for steel piles shall conform to AASHTO M 103/M 103M (ASTM A 27/A 27M), Grade 65-35 (450-240) or ASTM A 148/A 148M, Grade 90-60 (620-415) and shall be as included on the Qualified Products List.

## SECTION 510

### 2.2 Equipment for Driving Piles.

**2.2.1 Pile hammers.** Piles may be driven with steam, air, hydraulic or diesel hammers capable of driving piles at least 10 ft (3 m) longer than the longest pile length shown on the plans.

**2.2.1.1** Gravity hammers shall be subject to approval. When gravity hammers are permitted, the ram shall have a mass between 2,000 and 3,500 lb (900 and 1,600 kg) and the height of drop shall not exceed 15 ft (4.5 m). In no case shall the weight of gravity hammers be less than the combined weight of drive head and pile. All gravity hammers shall be equipped with hammer guides to insure concentric impact on the drive head.

**2.2.1.2** Open-end (single acting) diesel hammers shall be equipped with a device such as rings on the ram or a scale extending above the ram cylinder, to permit the Engineer to determine hammer stroke at all times during pile driving operations. The Contractor shall provide the Engineer a chart from the hammer manufacturer equating stroke and blows per minute for the open-end diesel hammer to be used. Closed-end (double acting) diesel hammers shall be equipped with a bounce chamber pressure gauge, in good working order, mounted near ground level so as to be easily read by the Engineer. In addition, for closed-end diesel hammers, the Contractor shall provide to the Engineer a chart calibrated to actual hammer performance within 90 days of use equating bounce chamber pressure to either equivalent energy or stroke.

**2.2.1.3** Non-impact hammers, such as vibratory hammers, or driving aids such as jets, followers, and prebored holes shall not be used unless specifically permitted in writing by the Engineer. When permitted, such equipment and driving aids shall be used only for production piles and only after the pile tip elevation necessary to provide the required ultimate resistance is established by load testing and/or test piles driven with an impact hammer. As a condition of approval of the non-impact hammers or driving aids, the Contractor shall perform, at no cost to the State, pile load tests and/or any additional work required to drive test piles, as determined by the Engineer. Installation of production piles with vibratory hammers shall be controlled according to power consumption, rate of penetration, or other means acceptable to the Engineer which assure pile load capacity equals or exceeds the test pile capacity. In addition, one of every ten piles driven with a vibratory hammer shall be retapped with an impact hammer of suitable energy to verify pile capacity.

**2.2.1.4** The plant and equipment furnished for steam and air hammers shall have sufficient capacity to maintain, under working conditions, the volume and pressure specified by the manufacturer. The plant and equipment shall be equipped with accurate pressure gauges. The weight of the striking parts of air and steam hammers shall not be less than 1/3 the weight of drive head and pile being driven, and in no case shall the striking parts have a mass less than 2,750 lb (1,250 kg).

### 2.2.2 Driving Appurtenances.

**2.2.2.1 Hammer cushion.** All pile driving equipment shall be equipped with a suitable thickness of hammer cushion material to prevent pile damage and insure uniform driving behavior. Hammer cushions shall be made of durable, manufactured materials, provided in accordance with the hammer manufacturer's guidelines except that all wood, wire rope, and asbestos hammer cushions are specifically disallowed and shall not be used. A striker plate as recommended by the hammer manufacturer shall be placed on the hammer cushion to insure uniform compression of the cushion material. The hammer cushions shall be inspected in the presence of the Engineer when beginning pile driving at each substructure element or after each 100 hours of pile driving, whichever is less. Any reduction of hammer cushion thickness shall be replaced by the Contractor before driving is permitted to continue.

**2.2.2.2 Pile cushion.** The heads of concrete piles shall be protected by a pile cushion made of plywood or other similar material approved by the Engineer. The minimum plywood thickness placed on the pile head prior to driving shall not be less than 4 in (100 mm). A new pile cushion shall be provided for each pile. In addition, the pile cushion shall be replaced if during the driving of any pile, the cushion is either compressed more than one-half the original thickness or begins to burn. The pile cushion dimensions shall match the cross-sectional area of the pile top.

**2.2.2.3 Pile drive head.** Piles driven with impact hammers require an adequate drive head to distribute the hammer blow to the pile head. The drive head shall be axially aligned with the hammer and the pile. The drive head should be guided by the leads and not be free-swinging. The drive head should fit around the pile head in such a manner as to prevent transfer of torsional forces during driving while maintaining proper alignment of hammer and pile.

**2.2.2.3.1** For steel piling the pile heads shall be cut squarely and a drive head, as recommended by the hammer manufacturer, shall be provided to hold the axis of the pile in line with the axis of the hammer.

**2.2.2.3.2** For precast concrete and prestressed concrete piles, the pile head shall be plane and perpendicular to the longitudinal axis of the pile to prevent eccentric impacts.

**2.2.2.3.3** For special types of piles, appropriate driving heads, mandrels or other devices shall be provided in accordance with the manufacturers' recommendations so that the piles may be driven without damage.

**2.2.2.4 Leads.** Piles shall be supported in line and position with leads while being driven. Pile driver leads shall be constructed in a manner that affords freedom of movement of the hammer while maintaining alignment of the hammer and the pile to insure concentric impact for each blow. Leads may be either fixed or swinging type. Swinging leads when used shall be fitted with a pile gate at the bottom of the leads. The pile section being driven shall not extend above the leads. The leads shall be adequately embedded in the ground or the pile constrained in a structural frame such as a template to maintain alignment. The leads shall be of sufficient length to make the use of a follower unnecessary and shall be so designed as to permit proper placing of batter piles. A free hammer and a rigid double template, which will independently support the pile, may be used when approved in writing by the Engineer.

**2.2.2.5 Followers.** Followers shall only be used when approved in writing by the Engineer, or when specifically stated in the contract documents. In cases where a follower is permitted, the first pile in each bent and every tenth pile driven thereafter shall be driven full length without a follower to verify that adequate pile length is being attained to develop the required ultimate resistance. The follower and pile shall be held and maintained in equal and proper alignment during driving. The follower shall be of such material and dimensions to permit the piles to be driven to the length determined necessary from the driving of the full length piles. The final position and alignment of the first two piles installed with followers in each substructure unit shall be verified to be in accordance with the location tolerances in 3.6.4 before additional piles are installed.

**2.2.2.6 Jets.** Jetting shall only be permitted if approved in writing by the Engineer or when specifically stated in the Contract documents. When jetting is permitted, the Contractor shall determine the number of jets and the volume and pressure of water at the jet nozzles necessary to freely erode the material adjacent to the pile without affecting the lateral stability of the final in-place jetted pile and adjacent piles. The Contractor shall control, treat if necessary, and dispose of all jet water in a manner satisfactory to the Engineer. The Contractor shall be responsible for all damage to the site caused by unapproved or improper jetting operations. When jetting is specifically required in the Contract documents, the jetting plant shall have sufficient capacity to deliver at all times a pressure equivalent to at

## SECTION 510

least 100 psi (690 kPa) at two 3/4 in (19 mm) jet nozzles. In either case, unless otherwise indicated, jet pipes shall be removed when the pile tip is a minimum of 5 ft (1.5 m) above prescribed tip elevation and the pile shall be driven to the required ultimate resistance with an impact hammer.

**2.2.2.7 Preboring.** When specified in the contract documents, the Contractor shall prebore holes at pile locations and to the depths shown on the plans. Prebored holes shall be of a size smaller than the diameter or diagonal of the pile cross section that is sufficient to allow penetration of pile to the specified depth. If subsurface obstructions, such as boulders or rock layers are encountered, the hole diameter may be increased to the least dimension which is adequate for pile installation. Any void space remaining around any type pile after driving shall be completely filled with sand or other approved material. The use of spuds, a short strong driven member which is removed to make a hole for inserting a pile, shall not be permitted in lieu of preboring.

**2.2.3 Approval of pile driving equipment.** All pile driving equipment furnished by the Contractor shall be subject to the approval of the Engineer. All pile driving equipment shall be sized to meet the requirements in 2.2.1. Approval of pile driving equipment by the Engineer will be based on wave equation analysis and/or other judgments. In no case shall the driving equipment be transported to the project site until approval of the Engineer is received in writing. Prerequisite to such approval, the Contractor shall submit to the Engineer the necessary pile driving equipment information at least 30 days prior to driving piles. The form for the above information is shown in Figure 1. A full size form will be included in the contract documents or supplied by the Engineer.

**2.2.3.1 Wave equation analysis.** The criteria, which the Engineer will use to evaluate the driving equipment from the wave equation results, consists of both the required number of hammer blows per in (25 mm) and the pile stresses at the ultimate pile resistance. The required number of hammer blows indicated by the wave equation at the ultimate pile resistance shall be between 3 and 15 per in (25 mm) for the driving equipment to be acceptable. The pile stresses which are indicated by the wave equation to be generated by the driving equipment shall not exceed the values where pile damage impends, if the equipment is to be acceptable.

**2.2.3.1.1** The point of impending damage in steel piles is defined herein as a compressive driving stress of 90 percent of the yield point of the pile material.

For concrete piles, tensile stresses shall not exceed the following:

In ENGLISH units:

3 multiplied by the square root of the concrete compressive strength,  $f'c$ , in pounds per square inch, plus the effective prestress value, in pounds per square inch,  $3\sqrt{f'c} + \text{prestress}$ .

In METRIC units:

0.25 multiplied by the square root of the concrete compressive strength,  $f'c$ , in megapascals, plus the effective prestress value, in megapascals,  $0.25\sqrt{f'c} + \text{prestress}$ .

Compressive stresses shall not exceed 85 percent of the compressive strength minus the effective prestress value ( $0.85 f'c - \text{prestress}$ ).

These criteria will be used in evaluating wave equation results to determine acceptability of the Contractor's proposed driving system.

**2.2.3.1.2** The Contractor will be notified of the acceptance or rejection of the driving system within 14 calendar days of the Engineer's receipt of the Pile and Driving Equipment Data Form. If the wave equation analysis shows that either pile damage or inability to drive the pile with a reasonable blow count

## SECTION 510

to the required ultimate resistance will result from the Contractor's proposed equipment or methods, the Contractor shall modify or replace the proposed methods or equipment until subsequent wave equation analysis indicates the piles can be reasonably driven to the required ultimate resistance, without damage. The Engineer will notify the Contractor of the acceptance or rejection of the revised driving system within 7 calendar days of receipt of a revised Pile and Driving Equipment Data Form.

**2.2.3.1.3** During pile driving operations, the Contractor shall use the approved system. No variations in the driving system will be permitted without the Engineer's written approval. Any change in the driving system will be considered only after the Contractor has submitted the necessary information for a revised wave equation analysis. The Contractor will be notified of the acceptance or rejection of the driving system changes within 7 days of the Engineer's receipt of the requested change. The time required for submission, review, and approval of a revised driving system shall not constitute the basis for a Contract time extension to the Contractor.

**SECTION 510**

TOWN: \_\_\_\_\_ BRIDGE NO.: \_\_\_\_\_  
 FED. PROJ. NO.: \_\_\_\_\_ MANUFACTURER: \_\_\_\_\_  
 DESCR. OF BRIDGE: \_\_\_\_\_ PILE DRIVING CONTRACTOR OR SUBCONTRACTOR: \_\_\_\_\_

(PILES DRIVEN BY)

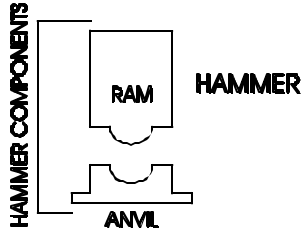

MANUFACTURER: \_\_\_\_\_ MODEL: \_\_\_\_\_  
 THICKNESS: \_\_\_\_\_ (in) SERIAL NO.: \_\_\_\_\_  
 RATED ENERGY: \_\_\_\_\_ (ft-lbs) AT \_\_\_\_\_ LENGTH OF STROKE

MODIFICATIONS: \_\_\_\_\_  
 \_\_\_\_\_  
 \_\_\_\_\_



MATERIAL: \_\_\_\_\_  
 THICKNESS: \_\_\_\_\_ (in) AREA: \_\_\_\_\_ (in<sup>2</sup>)  
 MODULUS OF ELASTICITY (E) \_\_\_\_\_ (P.S.I.)  
 COEFFICIENT OF RESTITUTION (e) \_\_\_\_\_

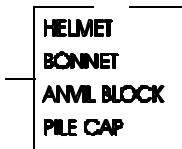
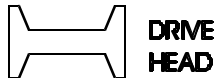

WEIGHT: \_\_\_\_\_ (lbs)



CUSHION MATERIAL: \_\_\_\_\_  
 THICKNESS: \_\_\_\_\_ (in)  
 MODULUS OF ELASTICITY (E) \_\_\_\_\_ (P.S.I.)  
 COEFFICIENT OF RESTITUTION (e) \_\_\_\_\_

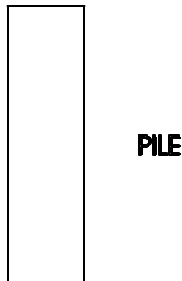

PILE TYPE: \_\_\_\_\_  
 LENGTH (IN LEADS) - \_\_\_\_\_ (ft)  
 WEIGHT/LENGTH: \_\_\_\_\_ (lbs/ft)  
 WALL THICKNESS: \_\_\_\_\_ (in) TAPER: \_\_\_\_\_  
 CROSS SECTIONAL AREA: \_\_\_\_\_ (in<sup>2</sup>)  
 DESIGN PILE CAPACITY: \_\_\_\_\_ (TONS)  
 DESCRIPTION OF SPLICE: \_\_\_\_\_

TP TREATMENT DESCRIPTION: \_\_\_\_\_

**NOTE:** IF MANDREL IS USED TO DRIVE THE PILE, ATTACH SEPARATE MANUFACTURER'S DETAIL SHEET(S) INCLUDING WEIGHT AND DIMENSIONS.

SUBMITTED BY: \_\_\_\_\_ DATE: \_\_\_\_\_

**FIGURE 1 - PILE AND DRIVING EQUIPMENT DATA FORM (ENGLISH)**

SECTION 510

TOWNE: \_\_\_\_\_ BRIDGE NO.: \_\_\_\_\_  
 FED. PROJ. NO.: \_\_\_\_\_ STATE PROJ. NO.: \_\_\_\_\_  
 DESCR. OF BRIDGE: \_\_\_\_\_ PILE DRIVING CONTRACTOR OR SUBCONTRACTOR: \_\_\_\_\_

(PILES DRIVEN BY)

HAMMER COMPONENTS

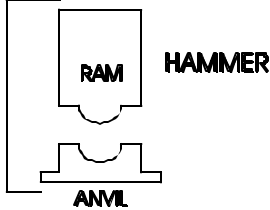

MANUFACTURER: \_\_\_\_\_ MODEL: \_\_\_\_\_  
 THICKNESS: \_\_\_\_\_ (mm) SERIAL NO.: \_\_\_\_\_  
 RATED ENERGY: \_\_\_\_\_ (J) AT \_\_\_\_\_ LENGTH OF STROKE

MODIFICATIONS: \_\_\_\_\_  
 \_\_\_\_\_  
 \_\_\_\_\_



MATERIAL: \_\_\_\_\_  
 THICKNESS: \_\_\_\_\_ (mm) AREA: \_\_\_\_\_ (mm<sup>2</sup>)  
 MODULUS OF ELASTICITY (E) \_\_\_\_\_ (MPa)  
 COEFFICIENT OF RESTITUTION (e) \_\_\_\_\_

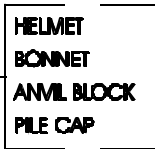
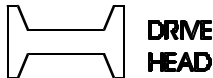

WEIGHT: \_\_\_\_\_ (kg)



CUSHION MATERIAL: \_\_\_\_\_  
 THICKNESS: \_\_\_\_\_ (mm)  
 MODULUS OF ELASTICITY (E) \_\_\_\_\_ (MPa)  
 COEFFICIENT OF RESTITUTION (e) \_\_\_\_\_

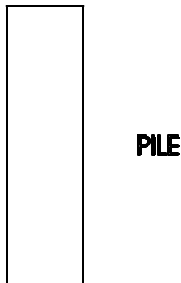

PILE TYPE: \_\_\_\_\_  
 LENGTH (IN LEADS) - \_\_\_\_\_ (m)  
 WEIGHT/LENGTH: \_\_\_\_\_ (kg/m)  
 WALL THICKNESS: \_\_\_\_\_ (mm) TAPER: \_\_\_\_\_  
 CROSS SECTIONAL AREA: \_\_\_\_\_ (mm<sup>2</sup>)  
 DESIGN PILE CAPACITY: \_\_\_\_\_ (METRIC TONS)  
 DESCRIPTION OF SPLICE: \_\_\_\_\_

TIP TREATMENT DESCRIPTION: \_\_\_\_\_

**NOTE:** IF MANDREL IS USED TO DRIVE THE PILE, ATTACH SEPARATE MANUFACTURER'S DETAIL SHEET(S) INCLUDING WEIGHT AND DIMENSIONS.

SUBMITTED BY: \_\_\_\_\_ DATE: \_\_\_\_\_

FIGURE 1 - PILE AND DRIVING EQUIPMENT DATA FORM (METRIC)

## SECTION 510

**2.2.3.2 Alternate approval method.** An alternate method of driving equipment approval will be used when either the Contract documents contain a provision that wave equation analysis will not be used for approval of driving equipment or the Engineer, in writing, waives the requirement for approval by wave equation analysis of pile driving equipment. The alternate approval method requires that the energy of the driving equipment submitted for approval on the Pile and Driving Equipment Data Form, be rated by the manufacturer at or above the appropriate minimum energy level in Table 1 below corresponding to the ultimate pile resistance shown on the plans.

**2.2.3.2.1** During pile driving operations, the Contractor shall use the approved system. If the Engineer determines the Contractor's hammer is unable to transfer sufficient energy to the pile, the hammer shall be removed from service until repaired to the satisfaction of the Engineer. No variations in the driving system will be permitted without the Engineer's written approval. Any changes in the driving system will be considered only after the Contractor has submitted a new Pile and Driving Equipment Data Form. The Contractor will be notified of the acceptance or rejection of the proposed driving equipment within 7 calendar days of the Engineer's receipt of the data form.

**Table 1 - ALTERNATE APPROVAL METHOD  
Minimum Pile Hammer Requirements (English)**

Ultimate Pile Resistance (Kips)	Minimum Manufacturer's Rated Hammer Energy (Foot-lbs)
180 and under	9,000
181 to 300	15,000
301 to 420	20,000
421 to 540	24,000
541 to 600	26,000
601 and over	Wave Equation Required

**Table 1 - ALTERNATE APPROVAL METHOD  
Minimum Pile Hammer Requirements (Metric)**

Ultimate Pile Resistance (kiloNewtons)	Minimum Manufacturer's Rated Hammer Energy (kiloJoules)
800 and under	12
801 to 1300	20
1301 to 1900	27
1901 to 2400	33
2401 to 2700	35
2701 and over	Wave Equation Required

### Construction Requirements

#### 3.1 General.

**3.1.1** The Contractor shall furnish the piles required after consultation with the Engineer, who will confirm or revise the lengths shown on the plans. When stated in the contract, the actual lengths for production piles will be determined by the Engineer after the completion of pile load tests.

**3.1.1.1** The Contractor shall, at his own expense, supply increased lengths to provide for fresh heading and for such additional length as may be necessary to suit his method of operation.

**3.1.2** The length of cast-in-place piles indicated on the plans is for estimating purposes only. The actual length of piles necessary shall be established in the field by driving the shells or pipes to the required ultimate resistance and penetration.

**3.1.3** Unless otherwise permitted, bearing piles shall not be driven until the excavation or fill, whichever the case may be, has been completed. The surface area through which piles are to be driven shall be cleared of all obstructions to driving. The Contractor's attention is called to 203.3.7.6 prohibiting placing rock or other objectionable material in the fill.

**3.1.4** Individual piles and pile groups shall be installed in such sequence that the soil surrounding the pile is not compacted to the extent that other piles in the group cannot be installed properly. The installation sequence shall be such that ground movement that would damage adjacent piles, structures or utilities is prevented.

**3.1.5** All material forced up between the piles shall be removed to the correct elevation before any foundation concrete is placed.

**3.1.6** When a pile strikes an obstruction in the upper level of the penetration depth, the Engineer may order exploratory excavation or removal of the obstruction, or both. Backfill material shall be compacted to the density ordered.

## **3.2 Piles.**

**3.2.1 Precast concrete piles.** When items for furnishing and driving precast concrete piles are included in the contract, the special provisions will specify the required methods of construction and handling.

### **3.2.2 Cast-in-Place Concrete Piles.**

**3.2.2.1 Shells.** Cast-in-place concrete piles shall be cast in metal shells which have been driven to the specified penetration and driving resistance and which shall remain permanently in place. The shells may be driven with or without a mandrel.

**3.2.2.2** The shell shall be both of watertight construction so that the concrete may be placed in the dry and of such thickness and rigidity as to show no signs of harmful distortion after being driven. The end closure shall be of adequate strength to resist driving damage and shall be tightly fastened to the shell to prevent water or soil infiltration. Neither the driving points nor the connection welds shall project more than 1/4 in (6 mm) beyond the perimeter of the pile tips.

**3.2.2.3** Full length shells shall be used where practicable. Shells may be spliced by welding with the approval of the Engineer. All welding shall be in accordance with 550.3.6 and 550.3.16. When built up sections are required either before or during the driving operation, care shall be taken to properly align the section to insure a straight axis for the pile. The connection shall be watertight. Built up sections during the driving operation shall be made at least 2 ft (600 mm) above the ground to permit observation of the behavior of the welded connections when driving resumes.

**3.2.2.4** The cut-offs shall be made at the elevation indicated on the plans or fixed by the Engineer. After the shell has been driven, it shall be inspected and approved before any concrete is placed. Shells which have been improperly driven or are defective shall be removed and replaced, or repaired to the satisfaction of the Engineer at the Contractor's expense.

## SECTION 510

**3.2.2.5 Reinforcement.** Reinforcing steel shall be of the design shown on the plans, of the unit type rigidly fastened together and lowered into the shell before concrete is placed up to the reinforcement area. The steel shall be secured in such a manner as to insure its proper location in the finished pile.

**3.2.2.6 Placing concrete.** All water shall be removed from shells before concrete is placed. Special care shall be taken to place the concrete so as to produce satisfactory bond with the reinforcement and avoid the formation of stone pockets, honeycomb, cold joints, or other such defects. During placing operations, the concrete in the reinforced portion of the pile shall be internally vibrated unless otherwise directed. Piles containing reinforcement shall be vibrated to at least the bottom of the reinforcement.

**3.2.2.6.1** All driving within 15 ft (4.5 m) of cast piles shall be discontinued for at least 7 days after the concrete has been placed or until the concrete has attained 80 percent of its desired strength.

### 3.2.3 Steel Piles.

**3.2.3.1** Steel piles shall be of the size and shape indicated on the plans, or as directed. They shall be handled and stored in such manner as to avoid deformation or injury.

**3.2.3.2 Mill test reports.** To establish proof and insure that the quality of the material in steel piles complies with the contract requirements, the Contractor shall submit to the Engineer two certified copies of Heat Number Identified Mill Test Reports showing physical test results and chemical analysis. Should the Contractor be unable to furnish mill test reports as required above, the Contractor shall have a sufficient number (three minimum) of samples tested at an established metallurgical laboratory and furnish to the Engineer three certified copies of the test reports indicating that the material is in compliance with the contract documents. Piling shall not be driven until the material has been accepted on the basis of either mill test reports or laboratory testing of samples.

**3.2.3.3 Inspection.** All piling shall be given a visual inspection at the site before driving to determine that the pile lengths contain no physical defects, such as kinks or buckles, that would cause the pile to fail in driving or not perform as intended.

**3.2.3.4 Pile points.** When driving-points are used, they shall be welded to the piles in the manner recommended by the manufacturer of the points and approved by the Department. The weld joint shall be prepared for a single-bevel groove weld by beveling the edge a minimum of 1/4 in (6 mm) at 45 degrees.

### 3.2.3.5 Splices.

**3.2.3.5.1** Each steel pile shall be provided in one piece without splices, unless splices are indicated on the plans, or otherwise permitted. When splicing is permitted, extensions 5 ft (1.5 m) or more in length at the butt end shall be used.

**3.2.3.5.2** Splices made on piles that are to be driven in pile bents, shall be made at points that will not be exposed to view, unless otherwise specifically directed or authorized by the Engineer, in which case they shall be finished to present a neat appearance.

**3.2.3.5.3** Unless otherwise directed on the plans or approved, the H-pile splice shall be a complete joint penetration groove butt weld using a 45 degree single-bevel groove weld (AWS BU4) on the flanges and web. The weld may be made by backgouging to sound weld metal and welding the second side, or by welding from one side using a 3/16 in (5 mm) backing bar and 1/4 in (6 mm) root opening.

**3.2.3.6 Welding.**

**3.2.3.6.1** All welding shall conform to the applicable requirements of Section 550.3.16, Field Welding.

**3.2.3.6.2** Welding shall only be performed by qualified welders.

**3.2.3.6.3** Welding shall be done with shielded metal arc (SMAW) using E6010 electrodes unless otherwise approved. Low hydrogen electrodes (E7018) may be used with proper storage and joint preparation. At the Contractor's option, self-shielding flux cored arc welding (FCAW-SS) may be used using E71T-6 or 8 wire for splices and E71T-11 for points.

**3.3 Determination of Pile Driving Criteria.**

**3.3.1 Wave equation.** The wave equation analysis will be performed by the Engineer to evaluate the pile driving equipment as described in 2.2.3.1, and to establish the driving criteria that is necessary to achieve the required ultimate pile resistance. The driving criteria from the wave equation analysis may be modified during pile installation, based on the results of pile load testing as described in 3.4. Piles shall be driven with the approved driving equipment to the ordered length or other lengths necessary to obtain the required ultimate pile resistance. Jetting or other methods to facilitate pile penetration shall not be used unless specifically permitted either in the Contract documents or approved by the Engineer after revised driving criteria is established from the wave equation analysis. Adequate pile penetration shall be considered to be obtained when the specified driving criteria is achieved within 5 ft (1.5 m) of the tip elevation based on ordered length. Piles not achieving the specified driving criteria within these limits shall be driven to penetrations established by the Engineer.

**3.3.2 Dynamic formula.** The driving criteria to achieve the ultimate pile resistance will only be determined by dynamic formula if either the Contract documents contain a provision that dynamic formula shall be used or the Engineer approves dynamic formula use. In such case, piles shall be driven to a length necessary to obtain the ultimate pile resistance according to the following formula:

**ENGLISH**

$$R_U = 1.75 (E)^{1/2} \log (10N) - 100$$

Where:

$R_U$  = the ultimate pile resistance (kips)

$E$  = the manufacturer's rated hammer energy (ft-lb) at the ram stroke observed in the field.

$\log (10N)$  = logarithm to the base 10 of the quantity 10 multiplied by N, the number of hammer blows per in at final penetration (blows per inch).

**METRIC**

$$R_U = 6.685 (E)^{1/2} \log (10N) - 444.8$$

Where:

$R_U$  = the ultimate pile resistance (kN)

$E$  = the manufacturer's rated hammer energy (J) at the ram stroke observed in the field

## SECTION 510

$\log(10N)$  = logarithm to the base 10 of the quantity 10 multiplied by N, the number of hammer blows per 25 mm at final penetration (blows per 25 mm).

### 3.4 Pile load tests. Static and/or dynamic load tests shall be performed prior to driving of other piles.

**3.4.1 Static load test.** When required, load tests shall be performed by procedures set forth in ASTM D 1143 using the quick load test method, except that the test shall be taken to plunging failure or to the test load defined in the Contract, whichever occurs first. Testing equipment and measuring systems shall conform to ASTM D 1143. The Contractor shall submit detailed plans of the proposed loading apparatus for documentation in accordance with 105.02. The apparatus shall be constructed to allow the various increments of the load to be placed gradually without causing vibration to the test pile. When the load test requires the use of tension (anchor) piles, such tension piles shall be of the same type and diameter as the production piles and shall be driven in the location of permanent piles when feasible, except that timber or tapered piles installed in permanent locations shall not be used as tension piles. The safe pile load shall be defined as 50 percent of the failure load. The failure load for the pile shall be defined as follows: For piles 24 in (600 mm) or less in diameter or width, the failure load of a pile tested under axial compressive load is that load which produces a settlement of the pile head equal to:

#### ENGLISH

$$S_F = S + (0.15 + 0.008D)$$

Where:

$S_F$  = Settlement at failure in inches

D = Pile diameter or width in inches

S = Elastic deformation of total unsupported pile length in inches

For piles greater than 24 inches in diameter or width:

$$S_F = S + \frac{D}{30}$$

#### METRIC

$$S_F = S + (3.81 + 0.008D)$$

Where:

$S_F$  = Settlement at failure in millimeters

D = Pile diameter or width in millimeters

S = Elastic deformation of total unsupported pile length in millimeters

For piles greater than 600 mm in diameter or width:

$$S_F = S + \frac{D}{30}$$

**3.4.1.1** The top elevation of the test pile shall be determined immediately after driving and again just before load testing to check for heave. All piles which heave more than 1/4 in (6 mm) shall be redriven or jacked to the original elevation prior to testing. Unless otherwise specified in the contract, a minimum three-day waiting period shall be observed between the driving of any anchor piles or the test pile and the commencement of the load test.

**3.4.1.2** Upon completion of the load testing, any test or anchor piling not a part of the finished structure, shall be removed or cutoff at least 1 ft (300 mm) below either the bottom of footing or the finished ground elevation if not located within the footing area.

### **3.4.2 Pile dynamic load test.**

**3.4.2.1** The Department will conduct pile dynamic load testing using a Pile Dynamic Analyzer (PDA) to evaluate pile capacity, hammer performance and pile stresses. PDA testing requires mounting two strain gauges and two accelerometer transducers near the pile head which are connected with cables to the PDA processing unit.

**3.4.2.2** The number of PDA tests will be determined by the Engineer. At a minimum, PDA testing will be conducted on the first 2 piles per substructure that are driven. PDA testing may also be conducted on additional piles as directed by the Engineer. This may include piles that are suspected of being damaged, or piles that do not reach expected embedment depths. The Contractor shall notify the Engineer at least 10 days prior to the start of pile driving so that arrangements can be made with the Geotechnical Section of the Materials and Research Bureau to conduct the PDA testing.

**3.4.2.3** The Contractor shall assist the Engineer as required during the PDA testing. This includes providing access while the pile is on the ground to drill the gauge mounting holes, a safe and reasonable means of access to the pile head for attaching gauges after the pile is in the leads, adequate time for installation of gauges, and any necessary support personnel, equipment of materials. A minimum 30-foot long extension ladder shall be provided in order to allow access to the pile head to mount the gauges while the pile is in the leads. It is anticipated that approximately one hour would be necessary to attach the gauges to the pile and to prepare the PDA for testing. A power supply (12 Volts DC or 110 to 125 Volts AC) and extension cords shall be provided by the Contractor for powering the PDA equipment. No payment shall be made for delays in the Contractor's operations resulting from the PDA testing and for materials, personnel or equipment provided for assisting in the PDA testing.

**3.4.2.4** The PDA will be used to evaluate both the Contractor's driving system and the driving criteria from the wave equation analysis. Based on the results of the PDA data, the Engineer may require the Contractor to modify the pile driving system if the driving operation is found to be in non-conformance with 510.

**3.4.3 Test piles.** Test piles shall be driven when shown on the plans at the locations and to the lengths specified by the Engineer. All test piles shall be driven with impact hammers unless specifically stated in the plans. In general, the specified length of test piles will be greater than the estimated length of production piles in order to provide for variation in soil conditions. The driving equipment used for driving test piles shall be identical to that which the Contractor proposes to use on the permanent piling and shall conform with the requirements of these specifications. The Contractor shall excavate the ground at each test pile to the elevation of the bottom of the footing before the pile is driven.

**3.4.3.1** Test piles shall be driven to a hammer blow count established by the Engineer at the estimated tip elevation.

**3.4.3.2** Test piles that do not attain the hammer blow count specified above at a depth of 1 ft (300 mm) above the estimated tip elevation shown on the plans shall be allowed to "set up" for 12 to 24 hours

## SECTION 510

or less if directed by the Engineer, before being redriven. A cold hammer shall not be used for redrive. The hammer shall be warmed up before driving begins by applying at least 20 blows to another pile. If the bearing value is not attained on redriving, the Engineer may direct the Contractor to drive a portion or all of the remaining test pile length and repeat the "set up" - redrive procedure. Test piles driven to plan grade and not having the required ultimate resistance shall be spliced and driven until the required ultimate resistance is obtained. Redriving shall be restricted to a maximum of 3 in (75 mm) additional penetration or a maximum of 50 hammer blows.

**3.4.3.3** A record of the driving of the test piles will be prepared by the Engineer. The record will include the number of hammer blows per foot (meter) for the entire driven length, the as-driven length of test pile, the cutoff elevation, the penetration into the ground, and any other pertinent information requested by the Engineer. The Contractor shall provide the information listed in Figure 1 to the Engineer for inclusion in the record. If redrive is necessary, the Engineer will record the number of hammer blows per 1 in (25 mm) of pile movement for the first foot (300 mm) of redrive. If stated in the Contract, the Contractor shall not order piling to be used in the permanent structure until test pile data has been reviewed and permanent pile lengths are authorized by the Engineer. The Engineer will provide the pile order list within 7 calendar days after completion of all test pile driving specified in the contract documents.

### 3.5 Required Ultimate Resistance.

**3.5.1** Piles shall be driven to the penetration shown on the plans or to a greater depth if necessary to obtain the required ultimate resistance. The driving criteria necessary to achieve the ultimate resistance will be determined by the Engineer based on methods listed in 3.3 and 3.4.

**3.5.2** The ultimate resistance of piles driven with a follower shall be considered acceptable only when the follower driven piles attain the same tip elevation as a full length pile driven without a follower, in accordance with the required driving criteria.

**3.5.3** Jetting or other methods shall not be used to facilitate pile penetration unless specifically permitted in the Contract plans or in writing by the Engineer. The ultimate pile resistance of jetted piles shall be based on impact driving blow count criteria after the jet pipes have been removed. Jetted piles not attaining the required ultimate resistance at the specified tip elevation shall be spliced if necessary at no cost to the State and driven with an impact hammer until the required driving criteria is met.

**3.5.4** The ultimate resistance of piles driven with a vibratory hammer shall be based on impact driving blow count of the first pile in each group of 10 piles. Vibrated piles not attaining the required ultimate resistance value at the ordered length shall be spliced, if necessary, at no cost to the State, and driven with an impact hammer until the required driving criteria is met. When the required ultimate pile resistance is attained, the remaining nine piles shall be installed to similar depths with similar vibratory hammer power consumption and rate of penetration as the first pile.

### 3.6 Preparation and Driving.

**3.6.1** The heads of all piles shall be plane and perpendicular to the longitudinal axis of the pile before the drive head is attached. The heads of all concrete piles shall be protected with a pile cushion.

**3.6.2** During pile driving, the capblock and pile cushion shall be changed as described in 2.2.2 before excessive compression or damage takes place. Approval of a pile hammer relative to driving stress damage shall not relieve the Contractor of responsibility for piles damaged because of misalignment of the leads, failure of capblock or cushion material, failure of splices, malfunctioning of the pile hammer, or other improper construction methods. Piles damaged for such reasons shall be rejected and replaced at the Contractor's expense when the Engineer determines that the damage impairs the strength of the pile.

**3.6.3 Preboring.** Spudding, auguring, wet-rotary drilling or other methods of preboring shall be used only when approved by the Engineer or in the same manner as used for any test piles. When permitted, such procedures shall be carried out in a manner which will not impair the carrying capacity of the piles already in place or the safety of existing adjacent structures.

**3.6.3.1** Except for end bearing piles, preboring shall be stopped at least 5 ft (1.5 m) above pile tip elevation and the pile shall be driven with an impact hammer in accordance with the driving criteria specified by the Engineer. Where piles are to be end-bearing on rock or hardpan, preboring may be carried to the surface of the rock or hardpan and the piles shall be retapped with an impact hammer to insure proper seating.

**3.6.3.2** If the Engineer determines that pre-excavation has disturbed the load bearing capacity of previously installed piles, those piles that have been disturbed shall be restored to conditions meeting the requirements of this specification by redriving or by other methods acceptable to the Engineer. Redriving or other remedial measures shall be instituted after the preboring operations in the area have been completed. The Contractor shall be responsible for the costs of any necessary remedial measures unless the preboring method was specifically included in the Contract documents and properly executed by the Contractor.

**3.6.4 Location and alignment tolerance.** The tops of piles at cut-off elevation shall be within 2 in (50 mm) of plan locations for bent cap supported by piles and shall be within 6 in (150 mm) of plan locations for all piles capped below final grade. Furthermore, the as-driven centroid of load of any pile group at cut-off elevation shall be within 5 percent of the plan location of the designed centroid of load. No pile shall be nearer than 4 in (100 mm) from any edge of the cap. Any increase in size of cap to meet this edge distance requirement shall be at the Contractor's expense.

**3.6.4.1** Piles shall be installed so that the axial alignment of the top 10 ft (3 m) of the pile is within 4 percent of specified alignment. For piles that cannot be inspected internally after installation, an alignment check shall be made before installing the last 5 ft (1.5 m) of pile or after installation is completed provided the exposed portion of the pile is not less than 5 ft (1.5 m) in length. The Engineer may require that driving be stopped in order to check the pile alignment. If the location and/or alignment tolerances specified are exceeded, the extent of overloading shall be investigated and if, in the judgment of the Engineer, corrective measures are necessary, suitable measures shall be designed and constructed by the Contractor at no cost to the State. Pulling laterally on piles to correct misalignment or splicing a properly aligned section on a misaligned section shall not be permitted.

**3.6.5 Heaved piles.** Elevation readings to check on pile heave after driving shall be made with a survey level at the start of pile driving operations and shall continue until the Engineer determines that such checking is no longer required. Level readings shall be taken immediately after the pile has been driven and again after piles within a radius of 15 ft (4.5 m) have been driven. The heave of shell piles shall be measured on a tell tale pipe that extends to the bottom of the shell, in order to verify that the shell tip has not heaved. If pile heave is observed, accurate level readings referenced to a fixed datum shall be taken on all piles immediately after installation and periodically thereafter as adjacent piles are driven to determine the pile heave range. All piles that have been heaved more than 0.25 in (6 mm) shall be redriven to the required resistance or penetration. Concrete shall not be placed in pile casings until pile driving has progressed beyond a radius of 15 ft (4.5 m) from the pile to be concreted. If pile heave is detected for pipe, shell, or tube piles which have been filled with concrete, the piles may be redriven after both the concrete has obtained sufficient strength and a proper hammer-pile cushion system satisfactory to the Engineer is used.

## SECTION 510

**3.6.6 Installation sequence.** The order of placing individual piles in pile groups shall be either starting from the center of the group and proceeding outwards in both directions or starting at the outside row and proceeding progressively across the group.

**3.6.7 Unsatisfactory piles.** The method used in driving piles shall not subject the piles to excessive or undue abuse producing crushing and spalling of concrete, injurious splitting, splintering, and brooming of the wood, or deformation of the steel. Misaligned piles shall not be forced into proper position. Any pile damaged during driving by reason of internal defects, or by improper driving, or driven out of its proper location, or driven below the designated elevation shall be corrected by the Contractor without added compensation by one of the following methods approved by the Engineer:

- (a) The pile shall be withdrawn and replaced by a new and, when necessary, longer pile. In removing piles, jets may be used in conjunction with jacks or other devices for pulling in an effort to remove the whole pile.
- (b) A second pile shall be driven adjacent to the defective pile.
- (c) The pile shall be spliced or built up as otherwise provided herein or a sufficient portion of the footing extended to properly embed the pile.
- (d) All piles pushed up by the driving of adjacent piles or by any other cause shall be retapped.

**3.6.7.1 Bent piles.** Piles which have been bent during installation shall be considered unsatisfactory unless the required ultimate resistance is proven by load tests performed at the Contractor's expense. If such tests indicate inadequate capacity, corrective measures as determined by the Engineer shall be taken such as use of bent piles at reduced capacity, installation of additional piles, strengthening of bent piles, or replacement of bent piles.

**3.6.7.2** A concrete pile will be considered defective if a visible crack, or cracks, appears around the entire periphery of the pile, or any defect is observed which, as determined by the Engineer, affects the strength or life of the pile.

**3.7 Cutting off piles.** The tops of all piling shall be cut off square to the axis at the elevations shown on the plans or as fixed by the Engineer. Unless ownership of the pile cut-offs is released to the Contractor by the Engineer, material cut off shall be loaded by the Contractor onto vehicles as directed by the Engineer.

### Method of Measurement

**4.1** Measurement of pile items will be made in accordance with the following table.

#### Methods and Units of Measurement

Item	Method	Unit
Pile Driving Equipment (All equipment furnished)		Unit
Pile Loading Tests (On plans and ordered)		Each
Pile Loading Tests (Not on plans but ordered)	Extra Work	
Furnishing Precast Concrete Piles	Total quantity listed on the plans or ordered	Linear foot (linear meter), to the nearest 0.1 of a 1 ft (meter)
Driving Precast Concrete Piles	Total quantity in place	Linear foot (linear meter), to the nearest 0.1 of a 1 ft (meter)
Cast-In-Place Concrete Piles*	Total quantity in place	Linear foot (linear meter), to the nearest 0.1 of a 1 ft (meter)

**SECTION 510**

Furnishing and Driving Steel Piles	Total quantity in place	Pound (Kilogram)
Steel Pile Cut-Off**	Total quantity remaining after steel piles are in place	Pound (Kilogram)
Pile Splices (On plans or ordered)		Each
Pile Splices (Not on plans and not ordered)	Subsidiary	
Chemical Admixture	Subsidiary	
Driving-Points for Steel Piles***		Each

\* Cut-off material from shells for cast-in-place concrete piles shall remain the property of the Contractor, and will not be measured for payment. No separate measurement will be made for reinforcing steel, excavation, drilling, cleaning of drilled holes, drilling fluids, sealing materials, concrete, required casing, and other items required to complete the work.

\*\* Steel pile cut-offs shall become the property of the Department. Extra pile lengths ordered for the purposes stated in 3.1.1.1 will not be included in this quantity.

\*\*\* No allowance will be made under furnishing or driving steel piles for the weight of driving-points.

**Basis of Payment**

**5.1** The accepted quantities of bearing piles and related items will be paid for at the contract price per unit of measurement complete in place.

**5.2** One-half the price bid for pile driving equipment will be paid when pile driving operations have started and the balance paid when the pile driving work has been completed.

**5.3** When test piles are ordered, they will be paid for on the same basis as the other piles unless there are no other piles driven and there is no item for pile driving equipment in the proposal, in which case the test piles will be paid for as extra work, consideration being given to the cost of transporting the driving equipment to and from the site of the work.

**5.4** Work ordered under 3.1.6 will be paid for as extra work except that no payment will be made for such work when the obstruction was placed there by the Contractor under the Contract.

**5.5** Steel pile cut-off material will be paid for at the invoice costs plus 15 percent.

**Pay items and units:**

510.1	Pile Driving Equipment	Unit
510.2	Pile Loading Tests	Each
510.41	Furnishing Precast Concrete Bearing Piles	Linear Foot (Linear Meter)
510.42	Driving Precast Concrete Bearing Piles	Linear Foot (Linear Meter)
510.5	Cast-in-Place Concrete Bearing Piles	Linear Foot (Linear Meter)

## SECTION 510

510.61	Furnishing and Driving Steel Bearing Piles	Pound (Kilogram)
510.65	Driving-Points for Steel Bearing Piles	Each
510.9	Pile Splices	Each

## ***SECTION 511 -- PREPARATION FOR CONCRETE BRIDGE DECK REPAIRS***

### **Description**

**1.1** This work shall consist of the preparation for repairs of concrete bridge deck including the removal of bituminous materials, the removal of unsound concrete from the existing deck to assure proper repair, and the disposal of all materials removed.

### **Equipment**

**2.1** The equipment used for pavement and concrete removal shall be subject to approval of the Engineer and shall comply with the following:

#### **2.1.1 Bituminous pavement removal.**

**2.1.1.1** The pavement removal may be performed with planers, backhoes, loaders, or other approved mechanical equipment.

#### **2.1.2 Bridge deck concrete overlay.**

**2.1.2.1** Scarifying equipment shall be either a power operated rotary scarifier or a high-pressure waterjet scarifier capable of uniformly scarifying the existing surface to the depth required in a satisfactory manner. Scarifying equipment shall be fully automated. Power operated rotary scarifiers shall be equipped with a short ski, shoe or a similar device attached to the cutter head to limit the depth of cut. The use of multiple impact or vibratory equipment will not be allowed.

**2.1.2.2** Sand or water blasting equipment shall be capable of removing rust and loose concrete from the exposed reinforcement and concrete surface.

#### **2.1.3 Bridge deck concrete partial or full depth repairs.**

**2.1.3.1** Sawing equipment shall be capable of cutting concrete to the specified depth.

**2.1.3.2** Power driven hand tools for concrete removal will be permitted with the following restrictions:

- (a) Jackhammers heavier than nominal 30 lb (13.6 kg) class shall not be used.
- (b) Jackhammers or mechanical chipping tools shall not be operated at an angle in excess of 45 degrees measured from the surface of the deck.
- (c) Chipping hammers heavier than nominal 15 lb (6.8 kg) class shall not be used to remove concrete from beneath any reinforcing bar.

(d) Hand tools, such as hammers and chisels, shall be used for removal of final particles of unsound concrete or to achieve the required depth of removal.

**2.1.3.3** High-pressure waterjet equipment, either hand held or remote controlled, will be permitted for concrete removal.

### **Construction Requirements**

**3.1** Concrete and pavement shall be removed from each area as shown on the plans or required. Removal areas as shown are based on Department studies; actual removal areas will be determined by the Engineer. The various classes of removal shall be accomplished according to the following requirements.

**3.1.1** When preparation for bridge deck concrete overlay is not specified, the concrete bridge deck pavement removal shall be accomplished with equipment capable of removing the existing bituminous pavement and membrane waterproofing without damaging the top surface of the deck concrete. The preparation of the deck surface prior to placement of new barrier membrane shall include removal of all existing membrane waterproofing and any membrane primer which is not tightly adhered to sound concrete. The Engineer may order sand blasting of a test area of primer to determine its acceptability for leaving in place. Additional preparation of the deck surface shall be as recommended by the manufacturer of the new barrier membrane to be applied.

**3.1.2** When preparation for bridge deck concrete overlay is specified, the entire existing concrete deck area shall be uniformly scarified to a minimum depth of 1/4 in (5 mm) or as specified on the plans. Removal to a greater depth will be required adjacent to scuppers and expansion joints and elsewhere, as shown on the plans or ordered. All full and partial depth repairs shall be performed prior to the scarification of the entire deck, unless otherwise permitted.

**3.1.3** When removal for partial or full depth repairs is specified, the concrete may be removed by chipping or by a combination of scarifying and chipping, except that final chipping, in any case, shall be by use of hand tools. The entire periphery of the partial or full depth removal areas shall be saw cut to a minimum depth of 1 in (25 mm) or to the top of the upper reinforcing steel. Care shall be taken to avoid cutting into any reinforcing bars. Care shall be exercised to prevent stretching or damaging exposed reinforcing steel.

**3.1.3.1** Partial depth removal for all concrete within the periphery of the designated removal area shall extend at least to 3/4 in (20 mm) below the lower bars of the top reinforcing steel mat, or deeper as required to remove all unsound concrete. The Engineer may require enlargement of a designated partial removal area should inspection reveal deterioration of concrete or corrosion of the reinforcing beyond the limits originally designated. In designated areas of partial depth removal where less than one half the designed deck thickness remains, all concrete shall be removed. Designated partial depth removal areas which become full depth removal shall be treated as full depth removal areas in accordance with 3.1.3.2. Limited areas of partial depth removal greater than half the slab thickness (such as beneath reinforcing) may be allowed by the Engineer. These limited areas of excess partial depth will be treated as partial depth removal.

**3.1.3.2** Full depth removal shall consist of removing all concrete for the full depth of the bridge deck. The lateral limits of this removal shall be to sound existing concrete, as determined by the Engineer. Areas where unsound concrete exists on the bottom surface of the deck shall be repaired by full depth removal even if the concrete directly above the unsound concrete is sound.

**3.1.3.2.1** Full depth concrete removal on those portions of the bridge deck over roadways, railroads or waterways shall be accomplished with the least possible disruption of the normal traffic flow under the deck. Special care and precautions, including protective structures as required or ordered, shall be taken

## SECTION 511

to insure that no debris is allowed to fall on any roadway, railroad, or waterway. All preparation work shall be carried out so as to prevent damage to those portions of the bridge that are to remain.

**3.2** The thickness of any new concrete above the prepared surface or reinforcing steel shall be at least 3/4 in (20 mm) and may be greater as shown on the plans. This clearance shall be checked according to the following:

**3.2.1** A filler block having a thickness of 1/8 in (3 mm) less than the required concrete thickness shall be attached to the bottom of the screed or an approved template, which shall then be passed over the area to be concreted. All old concrete which does not have sufficient clearance shall be removed. All reinforcing steel which does not have sufficient clearance shall be depressed. It may be necessary to remove concrete beneath some reinforcement to permit depressing the reinforcement adequately. Hand tools shall be used to remove final portions of concrete to achieve the required depth.

**3.3** Any slurry produced by wet sawing shall be thoroughly flushed from the concrete surface by a jet of water, and puddles of water shall be removed with an oil-free air blast before the start of any patching or overlay operations.

**3.4** All surfaces of existing concrete including any previously placed concrete to be in contact with the new concrete shall be thoroughly cleaned by sandblasting or high-pressure water-blasting.

**3.5** Reinforcing steel or other steel to be in contact with the new concrete shall be cleaned of all grease, dirt, concrete mortar and injurious rust. Injurious rust shall be interpreted to mean rust which is not firmly bonded to the steel. Rust which is difficult to remove by vigorous scrubbing with a wire brush shall be considered firmly bonded to the steel.

**3.6** Any portions of granite curb and mortar against which new concrete is to be placed shall be blast cleaned. Loose granite curb shall be reset in accordance with 609 of the Standard Specifications. Any deteriorated curb mortar bed shall be removed and replaced.

**3.7** After sandblasting or water-blasting and just prior to applying the bonding agent or grout in preparation for placement of the new concrete, all surfaces which will be in contact with new concrete shall be vacuum-cleaned or airblown. A combination of vacuum cleaning and airblowing may be required.

**3.8** After the bridge deck has undergone removal of old concrete and before new concrete has been placed and cured, construction loads shall not be permitted which exceed either a 8,000 lb (35.6 kN) wheel load or a 16,000 lb (71.2 kN) axle load. Any combination of axles spaced closer than 4 ft (1.2 m) center-to-center shall be considered as one axle. Placement of construction loads on the removal area shall be subject to approval of the Engineer.

### Method of Measurement

**4.1** Concrete bridge deck pavement removal and preparation for concrete bridge deck overlay will not be measured, but shall be the square yard (square meter) final pay quantity in accordance with 109.11 for the area within the limits shown on the plans.

**4.2** Preparation for partial depth concrete bridge deck repairs and preparation for full depth concrete bridge deck repairs will be measure by the square yard (square meter) to the nearest 0.1 of a square yard (square meter).

## SECTION 511

**4.2.1** Preparation for partial depth concrete bridge deck repairs and preparation for full depth concrete bridge deck repairs may be measured within the same areas as preparation for concrete bridge deck overlay with no reduction in the pay quantity of Item 511.01.

**4.2.2** Partial depth removal areas which become full depth removal areas will be measured as 511.03.

### Basis of Payment

**5.1** Concrete bridge deck pavement removal and preparation for concrete bridge deck overlay are final pay quantity items and will be paid for at the Contract unit price per square yard (square meter) in accordance with 109.11.

**5.1.1** The removal of bituminous materials on the roadway approaches will be paid for under 417.

**5.1.2** Protective structures if required will be subsidiary to 511.03.

### Pay items and units:

511.00	Concrete Bridge Deck Pavement Removal (F)	Square Yard (Square Meter)
511.01	Preparation for Concrete Bridge Deck Overlay (F)	Square Yard (Square Meter)
511.02	Preparation for Partial Depth Concrete Bridge Deck Repairs	Square Yard (Square Meter)
511.03	Preparation for Full Depth Concrete Bridge Deck Repairs	Square Yard (Square Meter)

## SECTION 512 -- PREPARATION FOR CONCRETE REPAIRS

### Description

**1.1** This work shall consist of inspecting and preparing existing deteriorated concrete surfaces for repairs at the locations shown on the plans and as directed by the Engineer. Since a significant portion of the work may involve discovering and repairing hidden deteriorated concrete, the Contractor should carefully inspect the work area before bidding.

### Construction Requirements

**3.1** Scaffolds shall be furnished and erected at those locations where necessary to perform inspection, preparation and repair work.

**3.2** Cleaning the concrete in preparation for the repairs shall include the following work as required and directed:

**3.2.1** Visually examining and testing the concrete surface by sounding with a hammer to detect hidden deterioration which is indicated by a hollow sound when struck. While work is in progress, the Contractor and Engineer shall jointly inspect and sound the concrete areas to be repaired to determine the limits of the work.

## SECTION 512

**3.2.2** Removing deteriorated concrete to a sound concrete surface free of laitance, dirt, or other foreign material shall be done by power brushing, the use of jackhammers where their use is allowed, sawing, sandblasting, waterblasting, mechanical abrading, hosing with water, air-blast cleaning, or other approved methods. If reinforcing steel is exposed when removing concrete to a sound surface, or if exposure of the reinforcing steel in prepared areas is required by the plans, the minimum depth of removal shall be 1-1/2 in (40 mm) behind the main reinforcing steel. If reinforcing steel is not exposed when removing concrete to a sound surface, and if exposure of the reinforcing steel in prepared areas is not required by the plans, the minimum depth of removal shall be 1/2 in (15 mm) plus the maximum coarse aggregate size of the patching material.

**3.2.3** The edges of all prepared areas shall be saw cut to a minimum depth of 1/2 in (15 mm) plus the maximum coarse aggregate size of the patching material. On vertical surfaces, if forms are to be used, the shape of the areas to be patched shall be such that the entire area to be patched is easily accessible, as determined by the Engineer. Although an occasional distribution or tie reinforcing bar may be cut, main reinforcing steel shall not be saw cut except as shown on the plans.

**3.2.4** Reinforcing steel or other steel to be in contact with the new concrete shall be cleaned of all grease, dirt, concrete mortar and injurious rust. Injurious rust shall be interpreted to mean rust which is not firmly bonded to the steel. Rust which is difficult to remove by vigorous scrubbing with a wire brush shall be considered firmly bonded to the steel.

### Method of Measurement

**4.1** Preparation for concrete repairs will be measured by the square yard (square meter) to the nearest 0.1 of a square yard (square meter) as determined by actual surface measurements of the lengths and widths of all the surfaces prepared.

**4.2** Areas prepared to a sound surface without exposing reinforcing steel will be measured as Class I preparation areas. Areas prepared to a sound surface a minimum of 1-1/2 in (40 mm) behind the reinforcing steel will be measured as Class II preparation areas.

### Basis of Payment

**5.1** The accepted quantity of preparation for concrete repairs will be paid for at the Contract unit price per square yard (square meter) complete.

#### Pay items and units:

512.01	Preparation for Concrete Repairs, Class I	Square Yard (Square Meter)
512.02	Preparation for Concrete Repairs, Class II	Square Yard (Square Meter)

## SECTION 520 -- PORTLAND CEMENT CONCRETE

DESCRIPTION 227

MATERIALS 229

2.1	CEMENT.....	229
2.2	AGGREGATES.....	230
2.3	CHEMICAL ADMIXTURES.....	232
2.4	BLANK.....	233

2.5 WATER..... 233

2.6 CURING MATERIALS FOR CONCRETE..... 233

2.8 WATERSTOPS..... 234

2.9 CONCRETE BONDING AGENT..... 234

2.10 STORAGE OF CONCRETE MATERIALS..... 234

2.11 CONCRETE MIXES..... 235

CONSTRUCTION REQUIREMENTS 238

3.1 PROPORTIONING AND BATCHING..... 238

3.2 FORMS AND FALSEWORK..... 246

3.3 WEEPERS AND DRAINS..... 247

3.4 READY-MIXED CONCRETE..... 247

3.5 PLACING CONCRETE..... 249

3.6 JOINTS..... 253

3.7 CONCRETING IN COLD WEATHER..... 254

3.9 FINISHING PLASTIC CONCRETE..... 255

3.10 CURING CONCRETE..... 256

3.11 LOADING CONCRETE..... 259

3.12 FINISHING..... 259

METHODS OF MEASUREMENT 260

BASIS OF PAYMENT 261

409

**Description**

**1.1 General.** This work shall consist of furnishing and placing portland cement concrete of the classes specified including fly-ash, silica fume, or ground granulated blast furnace slag as shown on the plans or as ordered.

**1.1.1** The work also consists of furnishing, placing, and curing structural portland cement concrete as shown on the plans or as ordered, to be accepted under Quality Assurance (QA) provisions.

**1.2 Classes of concrete.** The following classes of concrete are included in these specifications Table 1A - Method and Table 1B - Performance (QC/QA).

Table 1A - Classes of Concrete

Concrete Class	Minimum Expected 28 Day Compressive Strength <sup>1</sup>	Maximum Water/Cement Ratio <sup>2</sup>	Entrained Air Percent	Permeability Target Value <sup>6</sup>
	<b>PSI (Mpa)</b>			<b>Coulombs</b>
AAA3	5,000 (35)	0.400	5 to 9	2000
AAA	5,000 (35)	0.444	5 to 9	
AA3	4,000 (30)	0.400	5 to 9	2000
AA	4,000 (30)	0.444	5 to 9	2000
A	3,000 (20)	0.464	4 to 7	4000
B	3,000 (20)	0.488	3 to 6	
T	3,000 (20)	0.559	----	
F	304 (0.2)	3.0 to 4.05	15 to 255	

<sup>1</sup> See 3.1.6 TESTING

## SECTION 520

<sup>2</sup> For mixes containing fly-ash, silica fume, slag, or any other pozzolanic or cementitious material, the water/cement ratio of the concrete mix shall be based on the water cementitious (cement + pozzolanic or cementitious material) ratio of the mix. This water to cementitious ratio shall not exceed those listed in Table 1A. The maximum water/cement ratios listed for Concrete Class B and T are for design purposes only.

<sup>3</sup> Deck Overlays.

<sup>4</sup> Maximum 84 day Compressive Strength for Flowable Fill, Excavatable shall not exceed 200 psi (1.4 Mpa).

<sup>5</sup> These are recommended values that may be used as a starting point for a mix design that has shown ability to meet the requirements. The amount of cement shall be adjusted and fly-ash or ground granulated blast furnace slag shall be used provided the mix design meets the minimum and does not exceed the maximum compressive strength in accordance with 2.11.1.

<sup>6</sup> Target values shown are for mix design approval only and are not intended for use as quality control or quality assurance requirements.

**Table 1B - Class Of Concrete – Performance Requirements (QC/QA)**

CONCRETE CLASS	MINIMUM 28 DAY COMPRESSIVE STRENGTH	PERMEABILITY	AIR CONTENT		WATER/CEMENT RATIO		CONCRETE COVER
	PSI (MPa)		Coulombs	Percent	Percent	Percent	in (mm)
		Maximum	LSL	USL	LSL	USL	TV ± T
AA	4,000 (30.00)	7,000	5.0	9.0	Mean - 0.030	Mean + 0.030	1/2 (T = ± 12)
A	3,000 (20.00)	7,000	4.0	----	----	----	----
B	3,000 (20.00)	-----	3.0	----	----	----	----

LSL - lower specification limit

USL - upper specification limit

Mean - calculated mean of all test results for a lot.

TV - Target Value<sup>1</sup>

T - Tolerance

<sup>1</sup> Target value is defined as the typical clearance as shown on the plans or as ordered by the Engineer, for each location to be evaluated.

**1.2.1** Unless otherwise shown on the plans, the specified class of concrete shall be used in the following applications.

### 1.2.1.1 Method Requirements.

- (a) Footing concrete shall be Class B.
- (b) Concrete above footings shall be Class A.
- (c) Abutment backwall concrete shall be Class AA.
- (d) Concrete bridge decks shall be Class AA.

- (e) Concrete foundation seals shall be Class T.
- (f) Class F, Flowable Fill, Excavatable may be specified or requested in writing as a substitute for compacted gravel in embankment, granular backfill, structural fill, and pipe backfill. Approval in the form of a supplementary agreement shall be in consideration of, but not limited to, differential frost heaving due to dissimilar materials, unit weight structural requirements, lack of permeability, and damming resulting from water flow cut off. Flowable fill will not be allowed in lieu of pavement. Class F, Flowable Fill shall be a flowable, self-consolidating, rigid setting and low density material.
- (g) Precast concrete shall be Class AAA.

#### **1.2.1.2 Performance Requirements (QC/QA).**

- (a) Footing concrete shall be Class B.
- (b) Substructure concrete above footings shall be Class A except as shown in (c) and (d) below.
- (c) At grade approach slab concrete shall meet the requirements of and be paid as QC/QA Concrete Class AA, Item 520.0302X\_Concrete Class AA Approach Slabs (QC/QA).
- (d) Concrete bridge decks, copings, bridge sidewalks, abutment backwalls, and wing copings, shall meet the requirements of and be paid as QC/QA Concrete Class AA, Item 520.7X02\_Concrete Bridge Deck (QC/QA).
- (e) Concrete in rail support slabs shall meet the requirements of, and be paid as, QC/QA Concrete Class AA, Item 520.0202X\_Concrete Class AA, Rail Support Slab (QC/QA).
- (f) Class F, Flowable Fill, Excavatable may be specified or requested in writing as a substitute for compacted gravel in embankment, granular backfill, structural fill, and pipe backfill. Approval in the form of a supplementary agreement shall be in consideration of, but not limited to, differential frost heaving due to dissimilar materials, unit weight structural requirements, lack of permeability, and damming resulting from water flow cut off. Flowable fill will not be allowed in lieu of pavement. Class F, Flowable Fill shall be a flowable, self-consolidating, rigid setting and low density material.
- (g) Precast concrete shall be Class AAA.

**1.2.2** Retarding admixtures and Type G high range water reducing (HRWR) admixtures shall not be used in deck concrete when the existing air temperature is below 50° F (10° C) or forecasted to drop below 50° F (10° C) within 24 hours after completion of placement.

### **Materials**

#### **2.1 Cement.**

**2.1.1** Portland cement shall be Type II, or Type IP conforming to AASHTO M 85 or M 240 as appropriate, unless otherwise shown on the plans or permitted. Mill test reports shall be furnished with each delivery of cement.

**2.1.2** Cement used in visible portions of the work shall be the same brand, type, and color unless otherwise permitted.

## SECTION 520

**2.1.3** Cement containing lumps or partial set shall not be used.

### **2.1.4 Supplemental Cementitious Materials**

#### **2.1.4.1 Fly-Ash and Ground Granulated Blast Furnace Slag.**

**2.1.4.1.1** Fly-ash shall conform to Class C or Class F as described in AASHTO M 295 and shall meet the requirements of 2.2.4.3. Ground Granulated Blast Furnace Slag (GGBFS) shall be Grade 120 slag meeting the requirements of AASHTO M 302.

**2.1.4.1.2** Only one source of fly-ash or ground granulated blast furnace slag shall be used on any one project.

**2.1.4.1.3 Requirements.** Fly-ash shall conform to the chemical, physical and methods of sampling and testing requirements of AASHTO M 295 except that the CaO content shall be 8% or less and in the optional physical requirement, the multiple factor shall be 120 percent maximum. In addition, the fly-ash shall be subjected to the Air-Entrainment of Mortar Test as listed in ASTM C 311 and shall conform to the requirements as listed in the optional physical requirements of AASHTO M 295 for the uniformity requirements. Ground granulated blast furnace slag shall conform to the chemical, physical, and methods of sampling and testing requirements of Ground Iron Blast Furnace Slag for Use In Concrete and Mortars as listed in AASHTO M 302 except that the slag shall meet the requirement for slag activity index Grade 120.

**2.1.4.1.4 Certification.** The Contractor shall furnish the Department three copies of the materials test results and certification from each fly-ash or ground granulated blast furnace slag source proposed for use. The certification shall state the fly-ash or ground granulated blast furnace slag used on the project meets the requirement as stated in 2.1.4.1.3 and shall be for a specific, identifiable quantity.

**2.1.4.1.5** Fly-ash produced from a particular source shall be tested by the Contractor for loss on ignition and fineness at the frequency of one test per 100 tons (90 metric tons) used. Complete testing of fly-ash shall be done by the Contractor at a frequency of one test per 400 tons (350 metric tons) of fly-ash used or as directed by the Department.

**2.1.4.1.6** Under the direction of the Department, fly-ash or ground granulated blast furnace slag shall be sampled by approved means and shall be placed into a sealed container.

## **2.2 Aggregates.**

### **2.2.1 General.**

**2.2.1.1** All aggregates shall be thoroughly washed unless otherwise permitted. Aggregates shall be stockpiled for a minimum of 24 hours before use.

**2.2.1.2** The Contractor shall make arrangements for the Engineer to secure samples from all stockpiles in sufficient time to complete testing prior to starting concrete operations. If the stockpiled aggregates are approved, similar aggregates from the same sources will be considered acceptable, subject to the restrictions of the item for which the aggregates are to be used. No change in the source or character of the aggregates shall be made without prior notification to and approval by the Bureau of Materials and Research. Failure of any test taken prior to starting each placement will result in cancellation of the placement until corrective measures have been taken and the aggregates have been approved.

**2.2.1.3** Unless frozen aggregates are dispersed during mixing, they shall not be permitted.

**2.2.2 Method Requirements.****2.2.2.1 Fine Aggregate.**

**2.2.2.1.1** Fine aggregate shall consist of sand, stone screenings, or other inert materials with similar characteristics, or a combination thereof. Tests for organic impurities shall be in accordance with AASHTO T 21 and T 71.

**2.2.2.1.2 Required grading:****Table 2 - Fine Aggregate**

Sieve Size	Percentage by Weight Passing
3/8 inch (9.5 mm)	100
No. 4 (4.75 mm)	95 – 100
No. 16 (1.18 mm)	45 – 80
No. 50 (0.300 mm)	10 – 30
No. 100 (0.150 mm)	2 – 10
No. 200 (0.075 mm)	0 – 3

**2.2.2.1.2.1** The gradation of fine aggregate from any source shall be reasonably uniform and the fineness modulus as determined by AASHTO M 6 shall lie between 2.5 and 3.1. Fine aggregate showing a variation in fineness modulus greater than 0.2 above or below that upon which the mix was designed may be rejected.

**2.2.2.1.3** The requirements of 2.2.2.1.2 will not apply to fine aggregate for concrete class F, flowable fill. For concrete class F the fine aggregate grading shall be submitted with the mix design.

**2.2.2.2 Coarse Aggregate.**

**2.2.2.2.1** Coarse aggregate shall consist of crushed stone, gravel, or other approved inert materials with similar characteristics or combinations thereof, having hard, strong, durable particles, free from surface coating and injurious amounts of soft, friable, or laminated pieces, and free of alkaline, organic, or other harmful matter. Material passing the No. 200 (0.075 mm) sieve as determined by AASHTO T 11 shall not exceed 1.0 percent by weight. Thin or elongated particles shall not exceed 10 percent by number as determined by ASTM D 4791, on a 3 to 1 ratio and a minimum of 100 particles. The percent of wear shall not exceed 40 as determined by AASHTO T 96.

## SECTION 520

### 2.2.2.2.2 Required grading:

**Table 3 - Coarse Aggregate**

Class of Concrete	A <sup>1</sup> , B, and T	A, AA, and AAA	Overlay
Standard Stone Size	467	67	89
Nominal Size	1- 1/2 inch to No. 4 (37.5 to 4.75 mm)	3/4 inch to No. 4 (19.0 to 4.75 mm)	3/8 inch to No. 16 (9.5 to 1.18 mm)
SIEVE SIZE	PERCENTAGE BY WEIGHT PASSING		
2 inch (50 mm)	100		
1- 1/2 inch (37.5 mm)	95 - 100		
1 inch (25.0 mm)		100	
3/4 inch (19.0 mm)	35 - 70	90 - 100	
1/2 inch (12.5 mm)			100
3/8 inch (9.5 mm)	10 - 30	20 - 55	90 - 100
No. 4 (4.75 mm)	0 - 5	0 - 10	20 - 55
No. 8 (2.36 mm)		0 - 5	5 - 30
No. 16 (1.18 mm)			0 - 10
No. 50 (0.300 mm)			0 - 5

<sup>1</sup> 1-1/2 inch (37.5 mm) maximum size coarse aggregate for Class A concrete may only be used with approval of the Administrator, Bureau of Materials and Research.

**2.2.2.2.3** Unless otherwise specifically permitted, coarse aggregate shall be furnished and stockpiled in a minimum of 2 sizes and the amount of each size to be used shall be determined by combining the individual gradations of each stockpile mathematically to provide a well graded mixture conforming to Table 3.

### 2.2.3 Performance Requirements (QC/QA).

**2.2.3.1** Follow general requirements for aggregate section 2.2.1.

## 2.3 Chemical Admixtures.

**2.3.1** Air-entraining admixtures shall meet the requirements of AASHTO M 154. If the Contractor requests permission to use an unfamiliar air-entraining admixture, evidence shall be submitted to prove that the admixture complies with AASHTO M 154. The evidence shall be based on tests performed in a laboratory of a state transportation department, the FHWA, or in a laboratory which is regularly inspected by the Cement and Concrete Reference Laboratory of the National Bureau of Standards. Tests may be made on samples taken from a quantity submitted and certified by the manufacturer as representative of the admixture to be supplied.

**2.3.1.1** When using high range water reducing admixture the air entrainment admixture shall be a Vinsol Resin or approved equal conforming to AASHTO M 154.

**2.3.2** Water-reducing admixtures shall meet the requirements of AASHTO M 194, Type A.

**2.3.2.1** Water-reducing, high-range admixtures shall conform to AASHTO M 194 Type F or Type G.

**2.3.2.2** Corrosion inhibitor admixtures shall conform to AASHTO M 194 (ASTM C 494) Type C.

**2.3.3** Water-reducing and retarding admixtures (herein referred to as retarding admixtures) shall meet the requirements of AASHTO M 194, Type D.

**2.3.4** Calcium chloride may only be used with specific permission of the Bureau of Materials and Research.

**2.3.5** Chemical admixtures shall be products as included on the Qualified Products List.

**2.3.6** Admixtures shall be stored in a suitable building in such a manner as to permit easy access and identification and to protect the admixtures from freezing. Admixtures will be rejected if precipitation has occurred in the container.

**2.3.7** Silica Fume shall conform to AASHTO M307, Microsilica for use in Concrete and Mortar.

**2.3.7.1** Bags used to supply silica fume shall not be incorporated into the concrete.

**2.4** Blank.

**2.5** **Water.**

**2.5.1** Water for use in concrete shall be free from oils, acids, organic matter or other deleterious substances and shall not contain more than 500 parts per million of chlorides as Cl nor more than 1000 parts per million of sulfates as SO<sub>4</sub>. In addition water used in portland cement concrete shall be free from iron, tannic acid, and other impurities which may cause staining or discoloration.

Water from municipal supplies approved by the State of New Hampshire Department of Environmental Services will not require testing, but water from other sources will be sampled and tested before being used in concrete, once per source unless otherwise directed. Tests shall be made in accordance with AASHTO T 26. A sample of approximately 1 gallon (2 liters) will be obtained by Department personnel.

The hydrogen ion concentration (pH) shall be determined electrometrically or colorimetrically and be between pH 4.5 and pH 8.5.

The water shall not contain any impurities in amounts sufficient to cause unsoundness or marked change in the time of setting in the cement with which it is mixed, nor a reduction in mortar strength of more than 10 percent compared to the results obtained with distilled water.

**2.6** **Curing Materials for Concrete.**

**2.6.1** Burlap shall conform to AASHTO M 182. The use of worn burlap, burlap with holes, or burlap reclaimed from uses other than curing concrete will not be permitted.

**2.6.2** Sheet materials shall be waterproof paper, polyethylene film, or white burlap-polyethylene sheeting conforming to AASHTO M 171.

**2.6.3** Liquid curing compound shall be Type ID (fugitive dye), Class B or Type 2 (white pigmented), Class B conforming to AASHTO M 148 except as modified herein. The vehicle shall have a resin base and contain no waxy compounds. The compound shall dry to touch within 4 hours when applied at the rate of 1 gallon per 200 square feet (2 liters per 10 square meters) of concrete.

## SECTION 520

**2.6.3.1** Liquid curing compound shall be a product as included on the Qualified Products List.

**2.6.4** Cotton mats shall consist of a filling material of cotton "batting" 12 oz/square yard (minimum 400 grams/square meter); covered with unsized cloth 6 oz/Square Yard (minimum 200 grams/square meter); tufted or stitched to maintain stability. Mats shall be free from tears and shall be in good condition.

**2.6.5** Water for curing shall meet the requirements of 2.5, above.

**2.7 Preformed expansion joint fillers.** Preformed expansion joint fillers for concrete shall conform to AASHTO M 153, Type II, unless Type III is shown on the plans.

### **2.8 Waterstops.**

**2.8.1** Waterstops shall conform to 541.

### **2.9 Concrete Bonding Agent.**

**2.9.1** Concrete bonding agent shall be a product as included on the Qualified Products List and shall be used only where shown on the plans or ordered.

**2.9.2** Grout for bonding bridge deck overlays to existing concrete shall consist of equal parts by weight of portland cement and sand, mixed with sufficient water to form a slurry. The consistency of this slurry shall be such that it can be applied with a stiff brush or broom to the old concrete in a thin, even coating that will not puddle in low spots. For sealing vertical joints around repair or between adjacent lanes of overlay and at the curbs, this grout shall be thinned to paint consistency.

### **2.10 Storage of Concrete Materials.**

**2.10.1** The handling and storage of concrete materials shall be such as to prevent their segregation or contamination by foreign materials. When directed, the aggregates shall be stored on suitable platforms or on clean, level, paved surfaces if segregation or contamination continues to occur. Aggregates shall be stored in separate stockpiles sufficiently removed from each other to prevent the aggregates from becoming intermixed. To prevent spillage from one bin to the next, buckets used to fill the bins shall not be wider than the clear opening of the bins. Evidence of intermixing, segregation, or contamination will be cause for rejection.

**2.10.2** Unless otherwise permitted, cement shall be stored in approved weatherproof silos or buildings which will protect the cement from dampness. The floors of the buildings shall be sufficiently clear of the ground to prevent the absorption of moisture. When storage in the open is permitted, the cement shall be placed on raised platforms and completely covered with a waterproof covering.

**2.10.3** The locations of the stockpiles and the facilities for storing cement shall be subject to approval.

### **2.10.4 Storage of Fly-Ash or Ground Granulated Blast Furnace Slag.**

**2.10.4.1** The approved fly-ash or ground granulated blast furnace slag shall be stored in weather-tight storage facilities at the source and the concrete plant. The storage facilities shall be subjected to approval by the Department. All storage facilities shall be completely empty and clean before fly-ash or ground granulated blast furnace slag is deposited therein unless they contain fly-ash of the same type from the same source.

**2.10.4.2** Fly-ash or ground granulated blast furnace slag from different sources or of different types shall not be stored together in the same storage container. Adding fly-ash or ground granulated blast furnace slag to partially filled storage containers shall be allowed only for fly-ash or ground granulated blast furnace slag of the same type from the same source. Fly-ash added to a partially filled storage container shall not vary from the fly-ash in the container by more than  $\pm 0.5\%$  in Loss on Ignition and by more than  $\pm 5\%$  in Fineness.

**2.10.4.3** Fly-ash or ground granulated blast furnace slag remaining in bulk storage for a period greater than one year after completion of test will be resampled and retested before shipment or use. However, fly-ash or ground granulated blast furnace slag which has been in bulk storage more than two years from the time of original manufacture shall not be used. Fly-ash or ground granulated blast furnace slag stored over the winter at the concrete producing plant shall be retested for specification compliance.

**2.10.5** Shipping fly-ash or ground granulated blast furnace slag shall be in accordance with accepted techniques for bulk portland cement or as directed by the Department.

## **2.11 Concrete Mixes.**

### **2.11.1 General**

**2.11.1.1** The concrete mix shall be composed of a mixture of aggregate, cement, supplemental cementitious materials, water, and chemical admixtures as required. All concrete mix designs shall provide for mitigation of alkali silica reactivity by the following:

**2.11.1.1.1** The Contractor shall supply laboratory test reports that contain data on the mineralogy and potential reactivity for all aggregates being used in the concrete mix. All aggregates shall be tested in accordance with the requirements of AASHTO T 303 to determine alkali-silica reactivity. The laboratory supplying the test results shall provide evidence that the laboratory is properly equipped and qualified to perform the test methods. All test results submitted for alkali-silica reactivity shall be from tests conducted within one calendar year from the date the mix design is submitted to the Department.

**2.11.1.1.1** Mix designs using potentially alkali reactive aggregates shall include mitigation for reactivity and shall be submitted to the Department for approval. Mitigation of potentially reactive aggregates shall consist of one or more of the following methods: use of low alkali cement (less than 0.6 percent  $\text{Na}_2\text{O}$  equivalent); use of a mineral admixture; or use of a chemical admixture. The proposed mitigation method will be accepted for use after the NHDOT Bureau of Materials and Research reviews test results supplied by the Contractor that show the effectiveness of the mitigation. An effective mitigation technique shall reduce the mean expansion to below 0.10% for alkali-silica reactivity when tested in accordance with ASTM C 1567.

In lieu of the above, mitigation may be by substitution of a minimum 25% fly-ash or 50% ground granulated blast furnace slag for cement by weight

### **2.11.2 Method Requirements**

**2.11.2.1** The Contractor shall submit a mix design appropriate for the raw materials and blends of approved aggregates available for the specific project. The concrete mix design limits given in Table 4 or Table 5 indicate the master ranges of mixes permissible under this specification. The mix design shall be within the master ranges indicated for the particular class of concrete specified. The mix design for each mix shall establish a single percentage of aggregate passing each required sieve size in accordance with Table 4 and Table 5, a cement factor and a water cement ratio, target strength and target permeability as

## SECTION 520

shown in Table 1A. Approval of the mix design will include a tolerance range of +/- 1000 coulombs. Consideration for values below 1000 coulombs will be made for mix designs utilizing ternary blends developed to mitigate for ASR. Gradings which range from the maximum of one sieve size to the minimum of the next will not be permitted. Mix design submittals shall include results of strength and permeability testing. Strength test results shall be comprised of two test cylinders tested for compressive strength at 28 days (a set of two averaged to comprise one strength test) in accordance with AASHTO T 22 & 23. Rapid Chloride Permeability testing shall be completed in accordance with AASHTO T 277 at an age of 56 days. No concrete placement shall be started on a project until the Bureau of Materials and Research has approved the mix design for that placement. The mix design for each mix shall be in effect until modified in writing by the Bureau of Materials and Research.

**2.11.2.2** Should a change in sources of material be made, a new mix design shall be submitted per 2.11.2. When unsatisfactory results or other conditions make it necessary, the Engineer may establish a new mix design.

**2.11.2.1.2** Except for Class F, aggregate fractions shall be sized, uniformly graded and combined in such proportions that the resulting mix meets the grading requirements of Table 4 or Table 5

**2.11.2.1.2** Alternate mix designs for excavatable flowable fill and other categories of flowable fill, will be allowed, providing the mix design for each is approved by the Bureau of Material and Research. Other categories of flowable fill might include non-excavatable, ultra-light weight, very flowable or other combinations. Alternative flowable fill mix designs would be used when specified or ordered. All mix designs submitted for approval shall be accompanied by 5 test cylinders, which will be used to determine compressive strength, unit weight and excavatability. Test cylinders will be evaluated at 84 days. Compressive strength test cylinders will be prepared according to ASTM D 4832, as modified by NHDOT Test Procedure P-2.

### 2.11.2.5 Master Ranges for Combined Aggregates.

**Table 4 - Coarse Aggregate with Specific Gravity Less Than 2.700**

Sieve Size	Concrete Classes* A <sup>1</sup> , B, and T			Concrete Classes** A, AA, and AAA		
	Min. (PERCENT BY WEIGHT PASSING)	Desired	Max.	Min. (PERCENT BY WEIGHT PASSING)	Desired	Max.
1-1/2 inch (37.5 mm)	95	100	100			
1 inch (25.0 mm)		80			100	
3/4 inch (19.0mm)	56	68	80	94	97	100
1/2 inch (12.5 mm)		57			77	
3/8 inch (9.5 mm)	38	46	55	51	62	73
No. 4 (4.75 mm)	31	35	39	37	42	47
No. 8 (2.36 mm)		29			34	
No. 16 (1.18 mm)	16	23	30	19	27	35
No. 30 (0.600 mm)		14			17	
No. 50 (0.300 mm)	4	7	10	4	8	12
No. 100 (0.150 mm)	1	2	3	1	2	4
No. 200 (0.075 mm)	0	0	2	0	0	2

\*Class A<sup>1</sup>, B, and T based on fine aggregate content of 32 to 36 percent of the total aggregate.

\*\*Class A, AA and AAA based on fine aggregate content of 38 to 42 percent of the total aggregate.

<sup>1</sup> See footnote to Table 3.

**Table 5 - Coarse Aggregate with Specific Gravity 2.700 and Over (Metric)**

Sieve Size	Concrete Classes* A <sup>1</sup> , B, and T			Concrete Classes** A, AA, and AAA		
	Min. (PERCENT BY WEIGHT PASSING)	Desired	Max.	Min. (PERCENT BY WEIGHT PASSING)	Desired	Max.
1 1/2 inch (37.5 mm)	97	100	100			
1 inch (25.0 mm)		83			100	
3/4 inch (19.0 mm)	57	69	82	95	97	100
1/2 inch (12.5 mm)		61			81	
3/8 inch (9.5 mm)	45	52	59	55	65	76
No. 4 (4.75 mm)	36	40	44	42	47	53
No. 8 (2.36 mm)		34			40	
No. 16 (1.18 mm)	20	27	35	22	31	40
No. 30 (0.600 mm)		17			19	
No. 50 (0.300 mm)	4	8	12	5	9	14
No. 100 (0.150 mm)	1	2	4	1	2	4
No. 200 (0.075 mm)	0	0	2	0	0	2

\* Class A<sup>1</sup>, B, and T based on fine aggregate content of 38 to 42 percent of the total aggregate.

\*\*Class A, AA, and AAA based on fine aggregate content of 44 to 48 percent of the total aggregate.

<sup>1</sup> See footnote to Table 3.

### 2.11.3 Performance Requirements (QC/QA)

**2.11.3.1** Aggregate fractions shall be sized, uniformly graded, and combined in such proportions, that the resulting mix meets the grading requirements of the Contractor's concrete mix design.

**2.11.3.2** Thirty (30) days prior to the first concrete placement for each class of concrete specified, a concrete mix design shall be submitted to the Bureau of Materials and Research for approval. No class of concrete shall be placed on a project until its mix design is approved. The mix design shall contain the following:

- Compressive Strength
- Amount of Cement lb/cy (kg/cm) (including supplemental cementitious materials)
- Fine and Coarse Aggregate Gradation
- Air Content
- Water/Cement Ratio
- Chemical admixtures (types, Brand names, dosage ranges).
- Laboratory test results (Strengths, Air Content, W/C ratios, Slump)

**2.11.3.3** Should a change in sources of material be made, a new mix design shall be submitted per 2.11.3.2. When unsatisfactory results or other conditions make it necessary, the Engineer will require a new mix design.

## SECTION 520

### Construction Requirements

#### 3.1 Proportioning and Batching.

##### 3.1.1 Proportioning.

**3.1.1.1** All ingredients shall be measured by weight unless otherwise permitted. Scales shall be approved beam type with a separate tare beam or springless dial type, accurate to within 0.5 percent of the total load.

**3.1.1.2** Cement shall be weighed on a separate scale. Weights for bagged cement, when its use is permitted, shall be as specified on the bag; fractional bags shall not be used.

**3.1.1.3** Aggregate weights shall be saturated surface dry weights adjusted for moisture.

**3.1.1.4** Mixing water shall consist of free moisture on the aggregates, ice if added, and water added to the batch. Water added to the batch shall be measured by weight or an approved volumetric method to an accuracy of 1 percent. Water meters shall be so installed that they are unaffected by pressure or temperature changes in the water supply. Graduated tanks shall be equipped with outside taps and valves for checking their calibration.

**3.1.1.5** Each approved admixture shall be added to a separate portion of the fine aggregate or water as recommended by the manufacturer to eliminate premixing of the additives. Separate calibrated standpipes with positive action discharge tubes, readily visible from the batching area, shall be provided at all concrete producing plants regardless of metering devices.

**3.1.1.6** The ratio of substitution of cement to fly-ash or cement to ground granulated blast furnace slag shall be 1:1 by weight.

**3.1.1.7** When specified on the plans, corrosion inhibitor (calcium nitrate) admixture shall be as shown on the Department's Qualified Products List. Corrosion inhibitor shall be used at the rate recommended by the manufacturer unless otherwise directed by the Engineer.

##### 3.1.2 Batching.

**3.1.2.1** Batch plants shall meet the requirements of AASHTO M 157 except as modified herein. The plants shall have one bin for fine aggregate and one bin for each required size of coarse aggregate. Each bin shall discharge efficiently and freely into the weighing hopper.

**3.1.2.2** All new, replaced, or major modification of existing batching plants shall be equipped for fully automatic proportioning and batching of all ingredients including admixtures.

**3.1.2.2.1** Automatic batching plants shall be controlled by means of an approved automatic batch selector set to accurately deliver in proper sequence the designed mix proportions and admixtures required for the batch. The batch selector controls shall be locked and sealed during operation. Changes in selector controls or weight settings shall not be made without authorization. Provisions shall be made to vary the size of the batch without affecting the proportions of the design mix.

**3.1.2.2.2** All batch equipment in automatic plants shall be interlocked to prevent the discharge of any ingredient into the system until all batching controls have been cleared of the previous batch and the discharge gates and supply valves are closed.

**3.1.2.2.3** A moisture meter equipped with automatic adjustable compensating controls shall be installed to accurately and continuously measure the moisture content of the fine aggregate. The moisture compensating dial shall automatically adjust the amount of batch water added and the batch weight of the fine aggregate consistent with the variations of free moisture in the fine aggregate.

**3.1.2.2.4** If the automatic proportioning devices become inoperable or malfunction during a concrete placement, the plant may operate manually for the completion of the pour. If the breakdown is readily correctable or is due to a condition within the producer's control, the plant will not be permitted to operate. If unavailability of parts or service or any condition beyond the producer's control exists, written permission may be given to operate the plant manually for a specified period. Accuracy shall be maintained as specified in 3.1.1.

### **3.1.3 Testing Equipment and Facilities.**

#### **3.1.3.1 Method Requirements.**

**3.1.3.1.1** The necessary equipment as specified and ordered shall be provided at all batch plants. Approved enclosed space for the use of the Engineer for storage and use of the testing equipment shall be provided including proper lighting, ventilation, and heat. The equipment shall include the following:

- (a) Set of 8 inch (200 mm) brass sieves, full height- 2 inch (50 mm), sizes 3/8 inch, Nos. 4, 8, 16, 30, 50, 100, 200, (9.5 mm, 4.75 mm, 2.36 mm, 1.18 mm, 0.600 mm, 0.300 mm, 0.150 mm, 0.075 mm) with pan and cover.
- (b) Motor driven shaker for 8 inch (200 mm) sieves.
- (c) Scale, 2 000 grams capacity, 0.1 gram sensitivity.
- (d) Approved motor drive mechanical shaker, tray size 18 by 26 in (460 by 660 mm), 2-1/3 ft<sup>2</sup> (0.2 m<sup>2</sup>); screen sizes 1-1/2 inch, 1 inch, 3/4 inch, 1/2 inch, 3/8 inch, No. 4 and No. 8 (37.5 mm, 25.0 mm, 19.0 mm, 12.5 mm, 9.5 mm, 4.75 mm, and 2.36 mm).
- (e) Field scale, 70 lb (40 kg) capacity, and 0.1 lb (0.1 kg) sensitivity.
- (f) Drying equipment, hot plate or oven with tins.
- (g) Speedy Moisture Tester, 26 gram size. If approved electronic probes are used, the Speedy Moisture Tester requirement may be waived.
- (h) Sample splitter (riffle type).

**3.1.3.1.2** The following test equipment shall be furnished on all projects calling for 10 yd<sup>3</sup> (7.5 m<sup>3</sup>) or greater of concrete unless specifically waived:

- (a) Slump test set, (AASHTO T 119)
- (b) Air-Entrainment Meter (AASHTO T 152, Type B)
- (c) Curing box for concrete cylinders\*
- (d) Scoop and squared trowel, minimum 6 inch (150 mm) blade.  
On projects with more than 100 CY (75 m<sup>3</sup>) of concrete, the following additional test equipment will also be required:
- (e) Scale, minimum 70 lb (40 kg) capacity, 0.1 lb (0.1 kg) sensitivity
- (f) Steel "contractor's" wheelbarrow
- (g) Hoe and hand shovel
- (h) Ten foot (three meter) metal straightedge
- (i) Microwave oven, 700 watt, 120 volt, 60 hertz, minimum 1.3 ft<sup>3</sup> (0.04 m<sup>3</sup>), variable power from 10 to 100 percent.
- (j) A scale, minimum capacity of weighing a 5 kilogram sample, 1.0 gram sensitivity.

## SECTION 520

\* On projects with less than a total of 100 yd<sup>3</sup> (75 m<sup>3</sup>) of concrete, the curing box shall be relatively airtight with provisions for storing cylinders in damp sand or sawdust at temperatures between 60° F (16° C) and 80° F (27° C). On projects with more than 100 yd<sup>3</sup> (75 m<sup>3</sup>) of concrete, the curing box shall comply with the following specifications:

The internal dimensions shall be approximately 30 inch long by 18 inch wide by 19 inch deep (760 mm long by 460 mm wide by 480 mm deep). The top shall be hinged at the back and a lock shall be provided at the front. The interior shall be rustproof. A moisture-proof seal shall be provided between the lid and the box.

A drain pipe shall be provided through the side of the box. A grating shall be provided to hold the concrete cylinders above the water surface.

A minimum/maximum thermometer shall be installed to measure the internal temperature of the box. The thermometer shall be readable from outside of the box and shall be accurate to within 2 °F (1 °C). The thermometer shall have minimum graduations of 2 °F (1 °C). A thermostat shall maintain the water at a temperature of 72 ± 5 °F (22 ± 3 °C) when the ambient temperature is as low as -10 °F (-23 °C).

**3.1.3.1.3** When concrete is placed at more than one location simultaneously, the necessary testing equipment shall be furnished at each location.

**3.1.3.1.4** Testing equipment shall be calibrated by the Contractor in accordance with 106.03.

### **3.1.3.2 Performance Requirements (QC/QA)**

**3.1.3.2.1** The following test equipment shall be furnished on all projects calling for 10 yd<sup>3</sup> (7.5 m<sup>3</sup>) or greater of concrete unless specifically waived:

- (a) Slump test set, (AASHTO T 119)
- (b) 2 Air-Entrainment Meters (AASHTO T 152, Type B)
- (c) Curing box for concrete cylinders

Provide a sufficient number of boxes to hold all the required number of concrete test cylinders for a minimum period of 48 hours.

- (d) Scoop and squared trowel, minimum 6 inch (150 mm) blade.

On projects with more than 100 yd<sup>3</sup> (75 m<sup>3</sup>) of concrete, the following additional test equipment will also be required:

- (e) Scale, minimum 70 lb (40 kg) capacity, 0.1 lb (0.1 kg) sensitivity
- (f) Steel “contractor’s” wheelbarrow
- (g) Hoe and hand shovel
- (h) Ten foot (three meter) metal straightedge
- (i) Microwave oven, 700 watt, 120 volt, 60 hertz, minimum 1.3 ft<sup>3</sup> (0.04 m<sup>3</sup>), variable power from 10 to 100 percent. (Provide 2 for QC/QA)
- (j) A scale, minimum capacity of weighing a 5 kilogram sample, 1.0 gram sensitivity.
- (k) Sufficient number of microwave safe dishes.

**3.1.3.2.3** When concrete is placed at more than one location simultaneously, the necessary testing equipment shall be furnished at each location.

**3.1.3.2.4** Testing equipment shall be calibrated by the Contractor in accordance with 106.03.

**3.1.4 Consistency.****3.1.4.1 Method Requirements**

**3.1.4.1.2** Mortar proportions shall be kept to the lowest that will provide the desired workability. Mixing water shall be kept to the minimum that will produce the required consistency as measured in accordance with AASHTO T 119, as modified in 3.1.6, and does not exceed the water/cement ratio established by Table 1A unless authorized by the Engineer. Slumps shall be kept within the following limits unless otherwise permitted:

Footings and mass concrete	2 - 4 inch	(25 - 75 mm)
Columns and pedestals	2 - 4 inch	(50 - 100 mm)
Decks and sidewalks	2 - 4 inch	(50 - 75 mm)
Tremie concrete	6 - 8 inch	(150 - 200 mm)
Walls over 18 inch (460 mm) thick	2 - 4 inch	(50 - 75 mm)
Walls 18 inch (460 mm) thick and under	2 - 4 inch	(50 - 100 mm)
Concrete with High Range Water Reducer	8 inch maximum	(125 - 175 mm) maximum

**3.1.5 Air-Entrainment.**

**3.1.5.1** Air-entrainment of the required percentage shall be obtained by the use of air-entraining admixture unless otherwise permitted. Air content will be determined in accordance with AASHTO T 152, except as modified in 3.1.6.1.

**3.1.5.2** The percentage of air-entrainment for pumped concrete shall be taken at the discharge end of the pump line.

**3.1.6 Testing.****3.1.6.1 Method Requirements.**

**3.1.6.1.1** Test cylinders shall be made in accordance with AASHTO T 141 except that the entire sample for test cylinders and testing air-entrainment and slump may be taken at one time from the middle of the batch. Errors in proportioning or mixing as evidenced by excessive slump will be cause for rejection. Cylinders shall be made and cured in accordance with AASHTO T 23. To determine compliance with Table 1A, cylinders shall be tested in accordance with AASHTO T 22 and the test strength shall be the average compressive strength of at least two cylinders tested at the end of the 28 day curing period.

**3.1.6.1.1.1** For concrete class F, flowable fill cylinders for compressive strength tests will be prepared when required in accordance with ASTM D 4832 as modified by NHDOT Test Procedure P-2.

**3.1.6.1.2** When ordered by the Engineer, mixes will be reviewed for use by test samples of at least 5 yd<sup>3</sup> (4 m<sup>3</sup>) a minimum of 14 days prior to use on the project. Tests for water/cement ratio, air content and final slump on fresh concrete at maximum delivery time shall be performed. Cylinders for testing strength and permeability will be made and tested by the Department, if required. Tests of workability and finishing characteristics as well as any other test deemed necessary will be performed. Payment for test samples will be per 109.04.

**3.1.6.1.3** Unit weight shall be determined in accordance with AASHTO T 121.

## SECTION 520

### 3.1.6.2 Performance Requirements (QC)

**3.1.6.2.1** The Contractor shall administer an approved Process Quality Control Plan for each QC/QA Concrete class specified, hereinafter referred to as the "Plan", sufficient to ensure a product which meets the contract requirements. The Plan shall meet the requirements of 106.03.1.

**3.1.6.2.1.1** The Plan shall address all elements which affect the quality of the structural concrete including, but not limited to, the following:

- (a) Mix Design(s); including aggregate source and gradations
- (b) Concrete Supplier and Plant Location
- (c) Quality of Components
- (d) Stockpile Management
- (e) QC Inspection Activities
- (f) QC Testing and Inspection Report Forms and Process for Department Submittal
- (g) Process Quality Control Testing: include details for frequency, location and sampling methods for slump, air content, water content, temperature, and evaporation rate.
- (h) Placement Method(s) and Consolidation including proposed backup equipment.
- (i) Proposed Finishing Machines
- (j) Evaporation Control Procedures
- (k) Finishing and Curing Methods
- (l) Version of the Specification to be used.

**3.1.6.2.1.2** The Plan shall include the following personnel performing the described functions and meeting the following minimum requirements and qualifications:

- a) **Plan Administrator** meeting one of the following qualifications:

| Prior to April 1, 2008:

- 1) Professional Engineer registered in the State of NH with one year of highway experience acceptable to the Department.
- 2) Engineer-In-Training certified by the State of NH with two years of highway experience acceptable to the Department.
- 3) An individual with three years highway experience acceptable to the Department and with a Bachelor of Science Degree in Civil Engineering Technology or Construction.

| After April 1, 2008:

Certification as NETTCP QA Technologist will be required for Plan Administrators

- b) Process Control Technician(s) (PCT) shall utilize test results and other quality control practices to ensure the quality of aggregates and other mix components and control proportioning to meet the mix design(s). The Plan shall detail the frequency of sampling and testing, corrective actions to be taken, and documentation. The PCT shall periodically inspect all equipment utilized in proportioning and mixing to ensure it is operating properly and that proportioning and mixing conforms with the mix design(s) and other contract requirements. The Plan shall detail how these duties and responsibilities are to be accomplished and documented and whether more than one PCT is required. The Plan shall include the criteria utilized by the PCT to correct or reject unsatisfactory materials. The PCT shall be a New England Transportation Technician Certification Program Concrete Technician Level I or be a Construction Materials Technician Trainee under direct observation of a New England Transportation Technician Certification Program Concrete Technician Level I
- c) Quality Control Technician(s) (QCT) shall perform and utilize quality control tests at the job site to ensure that delivered materials meet the requirements of the mix design(s), including

temperature, water/cement ratio, air content, and strength. The QCT shall inspect all equipment utilized in transporting, placing, consolidating, finishing, and curing to ensure it is operating properly and that placement, consolidation, finishing, and curing conform with the contract requirements. The Plan shall detail frequency of sampling and testing, corrective actions to be taken, and documentation. The Plan shall detail how these duties and responsibilities are to be accomplished and documented, and whether more than one QCT is required. The Plan shall include the criteria utilized by the QCT to reject unsatisfactory materials. The QCT shall meet the same qualifications as the PCT.

**3.1.6.2.1.3** The Plan shall detail the coordination of the activities of the Plan Administrator, the PCT and the QCT.

**3.1.6.2.1.4** The Contractor shall provide a Delivery Record for each truck load of concrete. The Delivery Record shall include:

Contract Name & Number

Bridge Number

Manufacturing Plant (Batching Facility)

Name of Contractor (Prime Contractor)

Date

Time Batched/Time Discharged

Truck Number

Load Number

Quantity (Quantity Batched this Load)

Target Weights Per cubic yard (cubic meter) and Actual Batched Weights for:

1. Cement
2. Supplemental cementitious materials - Fly Ash, Ground Granulated Blast Furnace Slag and/or Silica Fume
3. Coarse Aggregate
4. Fine Aggregate
5. Water (including water added at the batch plant and at the project site)
6. Air-Entraining, Water Reducing and/or other Admixtures including brand, type, and quantity.
7. Aggregate Moisture (Percent)

The Delivery Record shall be signed by a Process Control Technician affirming the accuracy of the information provided.

**3.1.6.2.1.5** Concrete placed shall be sampled, tested, and evaluated by the Contractor in accordance with the minimum process quality control requirements in Table 6:

**Table 6 - Minimum Process Quality Control Requirements Class AA**

PROPERTY	TEST FREQUENCY	TEST METHOD
Slump	First 3 Loads per Pour Per Class of Mix Then as Needed to Control Operations, or When Visual Change in Mix or Change on the Certificate of Compliance	AASHTO T119
Air Content		AASHTO T152
Temperature		ASTM C 1064
Strength	As Needed to Control Operations	AASHTO T22 & 23
Water Content	As Needed to Control Operations	Per Approved Plan
Evaporation Rate <sup>(1)</sup>	Once per subplot	Per Appendix B

<sup>(1)</sup> For Concrete Class AA used in bridge decks and at grade approach slabs only.

**SECTION 520**

**Table 6a - Minimum Process Quality Control Requirements Class A and B**

PROPERTY	TEST FREQUENCY	TEST METHOD
Slump	As Needed to Control Operations	AASHTO T119
Air Content	As Needed to Control Operations	AASHTO T152
Temperature	As Needed to Control Operations	ASTM C 1064
Strength	As Needed to Control Operations	AASHTO T22 & 23
Water Content	As Needed to Control Operations	Per Approved Plan

**3.1.6.2.1.5.1** Water content will be controlled by a method proposed in the plan and approved by the Engineer. Concrete not meeting the plan minimum requirements for air content shall not be incorporated in the work.

**3.1.6.3 Performance Requirements - Quality Assurance (QA)**

**3.1.6.3.1** Structural concrete designated for acceptance under Quality Assurance (QA) provisions will be sampled once per subplot on a statistically random basis. Samples will not be taken until the Contractor has accepted the material for placement. Samples will be obtained in accordance with AASHTO T 141 as amended in 3.1.6.3.3 and will be tested and evaluated by the Department in accordance with 106.03.2 and the acceptance testing schedule in Table 7:

**Table 7 - Acceptance Testing Schedule**

PROPERTY	SUBLOT SIZE	TEST METHOD
Strength	See 520.3.1.7.2.1	AASHTO T 22 & 23
Permeability	See 520.3.1.7.2.1	AASHTO T 277
Air Content	See 520.3.1.7.2.1	AASHTO T 152
Water/Cement Ratio	See 520.3.1.7.2.1	NHDOT Microwave
Concrete Cover	Each Data Point	Rebar Depth Measuring Unit See 520.3.1.7.3.3

**3.1.6.3.2 Lot Size.** For the purpose of evaluating all acceptance test properties, a lot for Class A and B shall consist of the total quantity represented by each QC/QA Concrete item mix design. On contracts which include multiple structures a lot shall consist of the total quantity represented by each QC/QA Concrete item mix design for each structure. Each structure will be evaluated as a separate lot. The unit price for each QC/QA item will be determined per 5.8.1 for each structure. A lot for Class AA shall be a day's placement. A day's placement will be defined as all concrete placed on the same day or a continuous placement occurring over two or more days. For a lot to be evaluated for pay adjustment, it must have at least three sublots.

**3.1.6.3.2.1 Sublot Size.** The following schedule will determine the number and size of sublots for a days placement.

**Table 4 - Class A and B Number and Size of Sublots**

DAYS PLACEMENT PER QC/QA CONCRETE ITEM	NUMBER OF SUBLOTS
0 to 50 CY inclusive (0 to 40 m <sup>3</sup> inclusive)	1
>50 to 150 CY inclusive (40 to 115 m <sup>3</sup> inclusive)	2 split equally
>150 to 300 CY inclusive (115 to 230 m <sup>3</sup> inclusive)	3 split equally
Over 300 CY (Over 230 m <sup>3</sup> )	split equally <sup>(1)</sup>

<sup>(1)</sup> Sublots shall be greater than or equal to 100 cubic yards (75 m<sup>3</sup>) and less than 135 CY (100 m<sup>3</sup>).

**3.1.6.3.2.2 Sublot Size for Class AA.** A sublot for Class AA shall typically be 50 cy (40 m<sup>3</sup>). Lots less than 175 cy (135 m<sup>3</sup>) shall be split equally into three equal sublots. A day's placement of less than 50 cy (40 m<sup>3</sup>) shall be tested as a sublot of the previous lot (if there is no previous lot it shall be a sublot of the subsequent lot). The last sublot shall be greater than or equal to 25 cy (20 m<sup>3</sup>) and less than 75 cy (60 m<sup>3</sup>).

**3.1.6.3.2.3 Sublot Size for Class A and B.** If a QC/QA Class A or B concrete item cannot be evaluated with at least three sublots using the above Table 8, then the engineer's estimate of the total quantity for that QC/QA concrete item will be split equally into three sublots.

**3.1.6.3.3** When concrete is placed by pumping, samples will be taken at the discharge end of the pump.

**3.1.6.3.4 Rapid Chloride Permeability.** Rapid Chloride Permeability test will be conducted on samples obtained by the Bureau of Materials & Research and performed in accordance with AASHTO T 277 at an age of 56 days or later. Samples for all placements for Class AA and for all placements for Class A will be cut from the middle half of 4 in x 8 in (100 x 200 mm) cylinders. One sample will be taken per sublot placed, with no less than three samples per lot. When concrete is specified to contain a corrosion inhibitor containing calcium nitrite, permeability testing will not be done and the pay factor for this concrete will be 1.0.

**3.1.6.3.5 Water Cement Ratio.** Water Cement Ratio shall be determined using the New Hampshire Department of Transportation microwave method as described in Appendix A of Section 520 contained in this special provision.

**3.1.6.3.6 Concrete Cover.** Concrete cover over reinforcing steel will be evaluated by the Bureau of Materials and Research. The Contractor shall give three working days notice to the Bureau of Materials and Research of the availability of the concrete section to be measured. A date will be scheduled to measure the cover. Prior to measurement, the Engineer, will provide locations for the measurements to be taken. The Contractor shall be responsible for marking the layout for rebar cover measurement and shall ensure adequate accessibility for measurement apparatus on the concrete section to be measured on the date scheduled. Concrete cover over reinforcing steel will be evaluated as follows:

- a) **Bridge Decks.** Concrete cover will be determined with a GSSI SIR2 radar rebar depth measuring unit. A run of measurements will be taken parallel to the centerline within each lane over 10 feet (3 meters) wide. A hole for calibration shall be taken for each placement. A depth verification hole shall be taken for each run. Coping areas, backwalls and areas on the deck where the top and bottom of the deck are not parallel or where the angle at the crown is changing will not be evaluated for cover.
- b) **Pedestrian sidewalks.** Concrete cover will be determined with GSSI SIR2 radar rebar depth measuring unit. A run of measurements will be taken along the centerline of the sidewalk. One hole will be taken for depth calibration. Concrete in the sidewalks will be evaluated as a separate lot for cover
- c) **At Grade Approach Slabs.** Concrete cover will be determined with a GSSI SIR2 radar rebar depth measuring unit. A run of measurements will be taken parallel to the centerline within each lane over 10 feet (3 meters) wide. A depth verification hole will be taken for each run for calibration.
- d) **Rail support slabs.** Concrete cover will be determined with GSSI SIR2 radar rebar depth measuring unit. A run of measurements will be taken parallel to the curb line, offset 1'-6" towards the roadway edge of the slab. A depth verification hole will be taken for each run for calibration.

## SECTION 520

**3.1.6.3.7** Evaluation of materials will be made using the specification limits in Table 1B.

**3.1.6.3.7.1** Concrete produced in accordance with a Contractor-provided mix design which fails to meet the specified compressive strength at 28 days, based on the average of two concrete cylinders per subplot, will be evaluated by comparison of the actual compressive strength ( $f'_{ca}$ ) with the specified compressive strength ( $f'_c$ ) as follows:

1. If ( $f'_c - f'_{ca}$ ) is less than 60 psi (400 kPa), the concrete will be accepted as being in conformance and no pay adjustment shall apply.
2. If the ( $f'_c - f'_{ca}$ ) value is between 60 and 500 psi (400 kPa and 3500 kPa) the Engineer may:
  - a) Require corrective action at no additional expense to the Department; or
  - b) Accept the concrete with a calculated pay adjustment as described in 5.9.2.
3. If the ( $f'_c - f'_{ca}$ ) value is greater than 500 psi (3500 kPa), the lot will be rejected and subject to the provisions of 106.03.2.2.

**3.1.6.3.7.2** On bridge decks, approach slabs and rail support slabs, when the average actual concrete cover over the top bar of the top mat of the reinforcing steel is less than the lower specification limit, the Contractor shall correct the deficiency. A plan to correct the deficiency shall be submitted to the Engineer for review and acceptance prior to performing any work. An acceptable plan could include, but not be limited to, grinding the surface and applying a concrete overlay.

When the average concrete cover over the reinforcing steel is greater than the upper specification limit corrective action may be required.

**3.1.6.3.7.3** Concrete placement operations may be suspended when the pay factor of any property for a lot, as determined in accordance with 106.03.2.4:

1. Drops below 1.00 and the Contractor is taking no corrective action, or
2. Is less than 0.90.

The placement operations shall not resume until the Engineer determines that material meeting the contract requirements can be produced.

### **3.2 Forms and Falsework.**

**3.2.1** Drawings and data for falsework shall be submitted for documentation in accordance with 105.02. A concrete density of 150 lb/ft<sup>3</sup> (2,400 kg/m<sup>3</sup>) and a live load of 50 lb/ft<sup>2</sup> (245 kg/m<sup>2</sup>) shall be used in calculations. Adequate provisions shall be made for the effect of vibration and impact on the forms and falsework.

**3.2.2** Wood forms and bracing materials shall be of approved lumber, mortar tight, and free of imperfections on exposed surfaces. Forms shall have sufficient studs, walers, and stiffbacks to eliminate bulging and shrinking. Surfaces which will be exposed to view in the final structure shall be formed with plywood unless otherwise specified or permitted. Plywood which will not give a concrete finish essentially equal to new plywood shall not be used. All plywood shall be placed with the grain horizontal.

**3.2.3** Forms shall be installed to the lines and grades shown on the plans or ordered. Forms for grade lines exposed to view such as top of curbs, walls, bearing areas, and the like, shall be cut to grade unless otherwise permitted. Wood in contact with the concrete shall be treated with an approved form release compound prior to erection. Cleaning and inspection ports shall be provided as ordered.

**3.2.4** Ties and anchorages for use in forms above the top of footings shall be fabricated so as to be removed to a minimum depth of 2 inches (50 mm) without injury to the concrete.

**3.2.5** Chamfer strips shall be installed as shown on the plans or ordered. Joints which are to receive external waterproofing shall not be chamfered.

**3.2.6** Metal forms shall comply with the pertinent requirements of 3.2.2. Projections into the finished concrete surface will not be permitted. Connection devices shall hold the forms rigidly in alignment and shall be removed without injury to the concrete.

**3.2.6.1** Forms made of other materials such as fiberglass or plastic may be used when permitted.

**3.2.7** Falsework shall be placed on an approved solid footing or piling. Provisions shall be made for adjusting forms to grade and compensating for settlement during placement of concrete. Improper or inadequate bracing shall be satisfactorily corrected.

**3.2.8** Stay-in-place deck forms shall not be used unless specifically allowed on the plans.

### **3.3 Weepers and Drains.**

**3.3.1** Four inch (one hundred millimeter) weepers at approximately 10 ft (3 m) on centers shall be placed at the elevations shown or ordered unless otherwise directed. Coarse gravel or stone shall be placed at the inlets and outlets to permit unobstructed flow of the weepers. An approved geotextile patch may be substituted on the inlet end of weepers in place of the coarse gravel or stone.

### **3.4 Ready-Mixed Concrete.**

#### **3.4.1 General.**

**3.4.1.1** Ready-mixed concrete is defined as portland cement concrete manufactured for delivery in a plastic state. It shall be in compliance with AASHTO M 157 or as modified herein.

**3.4.1.2** Ready-mixed concrete shall be mixed and delivered to the point designated by means of one of the following combinations of operations:

- (a) Central-mixed concrete. Mixed completely in a stationary mixer and delivered in a truck mixer operating at agitation speed.
- (b) Shrink-mixed concrete. Mixed partially in a stationary mixer and the mixing completed in a truck mixer.
- (c) Transit-mixed concrete. Mixed completely in a truck mixer.

**3.4.1.3** Non-agitating equipment will not be permitted for transportation.

#### **3.4.2 Mixers.**

**3.4.2.1** Each mixer shall have metal plate or plates attached in a prominent place by the manufacturer, plainly marked with the gross volume of the drum, the capacity of the drum or container in terms of the volume of mixed concrete, and the mixing and agitating speeds. The volume of mixed concrete shall not exceed 63 percent of the total volume of the drum or container when the concrete is in transit or shrink-mixed, or 80 percent of the total volume when the concrete is central-mixed. Stationary mixers shall be equipped with an acceptable timing device that will not permit the batch to be discharged until the specified mixing time has elapsed.

**3.4.2.2** When loaded to capacity, all mixers shall be capable of combining the ingredients of the concrete into a thoroughly mixed and uniform mass, and of discharging the concrete with a satisfactory

## SECTION 520

degree of uniformity at a rate which will not inhibit the rate of placement required. The rate of discharge shall be governed by the speed of rotation and not by restrictions of the discharge opening.

**3.4.2.3** Mixers will be subject to inspection as frequently as considered necessary. If found unfit to function properly, the mixers will be disapproved for use until correct operating conditions have been restored. The pickup and throw-over blades shall be replaced or repaired when they have become worn 1 inch (25 mm) or more below the original height of the manufacturer's design, or have become loose, broken, bent, scalloped, or otherwise damaged. Any accumulation of hardened concrete shall be removed.

**3.4.2.4** The Engineer may make tests for consistency of individual samples at approximately the beginning, the midpoint, and the end of the load. If the concrete is not of uniform quality, the mixer shall not be used until the condition is corrected and the mixer has been reinspected and approved.

### 3.4.3 Mixing.

**3.4.3.1** Mixers shall be operated within the limits of their capacity as specified in 3.4.2.1 or as designated by the manufacturer of the equipment, whichever is less, and shall not exceed the speed of rotation designated by the manufacturer.

**3.4.3.1.1** When high range water reducing admixture is used, the mix shall be delivered with 2 yd<sup>3</sup> (1.5 m<sup>3</sup>) less than the manufacturer's rated capacity for mixing as specified in 3.4.2.1.

**3.4.3.2** When shrink-mixed or central-mixed concrete is used, mixing time shall be measured from the time all the solid material is in the drum. The batch shall be so charged that some water will enter in advance of the cement and aggregates and all water will be in the drum by the end of the first one fourth of the specified mixing time.

**3.4.3.3** Where mixer performance tests have not been made, the minimum mixing time for mixers having capacities less than 1 yd<sup>3</sup> (0.8 m<sup>3</sup>) shall be 1 minute. For mixers of greater capacity, the minimum mixing time shall be increased by 15 seconds for each cubic yard (cubic meter) of additional capacity or fraction thereof.

**3.4.3.4** When shrink-mixed concrete is used, the mixing time in the stationary mixer shall be at least that required to intermingle the ingredients. After transfer to a truck mixer, mixing at mixing speed and turning at agitating speed will be required as specified in 3.4.3.5.

**3.4.3.5** When transit-mixed concrete is used, mixing shall be performed at the site of the work unless otherwise permitted. If the required uniformity is not obtained within 100 revolutions of the mixer after all ingredients are in the drum, that mixer shall not be used until the condition is corrected. Additional revolutions of the mixer beyond the number found to produce the required uniformity shall be at agitating speed except as stated in 3.4.3.7.

**3.4.3.6** The Contractor shall provide a delivery record for each truck load of concrete. The delivery record shall include but not be limited to: date, time batched/time discharged, quantity (quantity batched this load), actual batched weights of: cement, admixtures, water, aggregates and aggregate moisture (percent). Target weights or out of tolerance notification will also be given for each of the actual batched weights given on the delivery record.

**3.4.3.7** Water shall not be added after the initial introduction of the mixing water to the batch except when the slump is unsatisfactory. Such additional water as necessary, up to the amount permitted in 1.2, may be added to bring the slump within the limits specified in 3.1.4. The drum shall then be

turned an additional 30 revolutions at mixing speed. Water shall not be added at any later time unless permitted.

**3.4.3.8** Mixing shall begin within the 30 minute period after the cement has been added to the aggregates unless otherwise permitted.

**3.4.3.9** When pumps are used, truck mixers shall be scheduled and adjusted to the capabilities of the pumping units and the rate of placement to provide continuous pumping without excessive waiting time before discharge. Whenever possible, pumps shall be placed so that 2 trucks may discharge into the pump hopper at the same time. Actual discharge shall be such that the last of the load of one is discharged into the hopper with the beginning portion of the other.

**3.4.3.10** Additional high range water reducing admixture, not to exceed the manufacturer's recommendation, may be required to be added at the project to reach slump requirements.

### **3.5 Placing Concrete.**

#### **3.5.1 General.**

**3.5.1.1** The Contractor shall notify the Engineer at least three working days in advance of each concrete placement to allow sufficient time to schedule required inspection and testing. A pre-pour conference shall be mandatory prior to any deck placement.

**3.5.1.2** Concrete shall not be placed without inspection. Concrete so placed will be removed at the Contractor's expense unless authorized by the Engineer.

**3.5.1.3** Approval will be required for alignment and grade, formwork and bracing, reinforcing steel and other inclusions, and the cleanliness of the forms prior to placing concrete.

**3.5.1.4** If the Contractor proposes to place concrete by pumping, a detailed plan outlining his proposed method of operation shall be furnished along with a list of the pumping units proposed, the manufacturer's specifications and capabilities of the units, slickline diameter and maximum length of same, diameter and length of any flexible lines proposed, and the allowable continuous pumping pressure of each unit. This information shall be furnished seven days in advance of the scheduled operation to permit study of the equipment and methods proposed and the satisfactory resolution of any questions arising.

#### **3.5.2 Equipment.**

**3.5.2.1** All equipment used in placing concrete shall be approved for the particular use intended. Equipment which will be in contact with the fresh concrete shall be mortar-tight and free of caked-on mortar and other contaminants. If other methods are not satisfactory, sandblasting will be required for cleaning.

**3.5.2.2** Crane buckets for placing concrete shall be low-slump type unless otherwise permitted.

**3.5.2.3** Chutes, when permitted, shall be of approved materials and installed so as to prevent segregation. Any sign of segregation will result in rejection of chuting and utilization of an alternate approved method of placement.

**3.5.2.4** Aluminum shall not be used in any equipment where it would be in contact with the fresh concrete.

## SECTION 520

**3.5.2.5** When pumping concrete, the number and lengths of flexible lines shall be kept to the minimum required for distribution. Transition sections used to reduce the diameter of lines shall be of slickline material and shall be as long as possible.

### **3.5.3 Placing.**

#### **3.5.3.1 General**

**3.5.3.1.1** Concrete shall be placed in its final location as soon as possible after mixing. Segregation of the mix or displacement of materials inside the forms will not be permitted.

**3.5.3.1.2** Concrete shall be placed in layers not to exceed 12 inch (300 mm) and placing intervals shall not exceed 30 minutes unless otherwise permitted. Concrete which has attained a partial set shall not be used.

**3.5.3.1.2.1** When placing deck concrete, concrete shall not be placed more than 10 ft (3 m) ahead of the finishing machine.

**3.5.3.1.3** In the event of unscheduled stoppage of the work, vertical bulkheads shall be installed to ensure a minimum depth of 6 inch (150 mm) of concrete in the next lift of concrete when placement is resumed. See 3.6.2 also.

**3.5.3.1.4** Care shall be taken to keep the concrete pressure on ties and forms within the design limits. Concrete shall not be dropped a distance of more than 5 ft (1.5 m) unless contained within a tremie, elephant trunk, or other approved system.

**3.5.3.1.5** Concrete which has attained its initial set shall not be disturbed by personnel, equipment, or other construction operations for a minimum period of 72 hours unless otherwise permitted.

**3.5.3.1.6** Defective sections of concrete shall be removed and replaced or repaired as directed.

**3.5.3.1.7** Means to contain concrete class F, flowable fill within a designated space shall be provided. Approved methods to prevent pipes from floating during placement of concrete shall be used.

**3.5.3.1.8** For earthen backfill operations or vehicle traffic for paving operations, concrete class F, flowable fill shall be left undisturbed until the material obtains sufficient strength to support the weight of foot traffic without deformation.

**3.5.3.1.9** When concrete is to be placed against granite bridge curb; the granite curb shall have been kept continuously wet for a period of 12 hours before coming into contact with the fresh concrete. Care shall be taken when removing soaking material to ensure that the curbing remains wet until the fresh concrete is placed against it. Any standing water shall be removed before the concrete is placed.

**3.5.3.1.10** When concrete is to be placed against any precast concrete member, the precast concrete member shall have been kept continuously wet for a period of 3 hours before coming into contact with the fresh concrete. Care shall be taken when removing soaking material to ensure that the member remains wet until the fresh concrete is placed against it. Any standing water shall be removed before the concrete is placed.

#### **3.5.3.2 Method Requirements.**

**3.5.3.2.1** Any concrete that is not in place 1 1/2 hours after the cement has been added to the aggregates shall not be used unless otherwise permitted

**3.5.3.3 Performance Requirements (QC/QA).**

**3.5.3.3.1** Concrete Class AA shall be placed to meet the following conditions for evaporation rates. Charts are given in Appendix B.

1. Evaporation rate shall not exceed 0.2 lb./sq ft/hr (1.0 kg/sq.-m/hr) for concrete with a water/cement ratio higher than 0.440.
2. Evaporation rate shall not exceed 0.1 lb./sq ft/hr (0.5 kg/sq.-m/hr) for concrete with a water/cement ratio 0.440 or under.

**3.5.4 Consolidation.**

**3.5.4.1** Unless otherwise permitted, consolidation of all concrete shall be achieved by the use of approved internal vibrators with a frequency range of 7,000 to 10,000 impulses per minute. Vibrators used in concrete containing epoxy coated reinforcing steel shall be equipped with a non-metallic or non-metallic-coated head. Concrete shall not be moved excessive distances by the use of vibrators.

**3.5.4.2** Vibrators shall be inserted vertically into the fresh concrete and withdrawn slowly. Vibration shall continue until consolidation is achieved and stopped before segregation occurs or water is forced to exterior concrete surfaces in appreciable amounts.

**3.5.4.3** Concrete shall not be placed at a rate greater than that which can be thoroughly consolidated by the vibrators in use. The number of vibrators required will be based on the maximum predicted rate of placement. At least one reserve vibrator shall be furnished.

**3.5.4.4** No consolidation or vibration of concrete class F, flowable fill is required.

**3.5.5 Depositing Concrete Under Water.**

**3.5.5.1** Unless otherwise specifically permitted, all concrete placed in water shall be placed by tremie. Slump shall comply with 3.1.4.

**3.5.5.1.1** Pumping for underwater placement of concrete shall also be into a tremie unless specific permission is given for direct placement by pump lines. Placement by direct pumping, if permitted, will require the hose to be securely fastened to the cofferdam frame at all times to eliminate surging of the hose in the concrete. If at any time the procedure becomes unacceptable, the remainder of the concrete shall be placed by a tremie. Tremie equipment shall be available on site prior to start of pumping operations.

**3.5.5.2** A tremie shall consist of a watertight tube attached to a hopper of approved size with an adequate working space provided around the hopper. The tremie shall be attached to a crane or other approved hoisting equipment to permit lifting and lowering the tremie with sufficient rapidity to control and stop the flow of concrete as required. The equipment shall be capable of moving the tremie over the entire surface of the placement area.

**3.5.5.3** At the start of placing operations, and at any time thereafter that the tremie is withdrawn from the concrete, an approved watertight plug shall be inserted into the discharge end of the tremie. The tremie shall be lowered until it rests on the bottom or in freshly deposited concrete. It shall then be checked for leaks. If watertight, the tremie tube and hopper shall immediately be filled with concrete. The hoisting mechanism shall then raise up the tremie to permit the discharge of the concrete without removal from freshly deposited concrete. The tremie shall then be lowered to stop the flow of concrete before it has dropped below the level of the bottom of the hopper. The hopper shall again be filled and

## SECTION 520

the process repeated until the desired intermediate or final grade is attained. Top concrete surfaces shall be approximately horizontal.

**3.5.5.4** Concrete foundation seals shall be placed as shown on the plans or ordered. The elevation of the top of the seal and the required depth may need to be determined after the excavation is completed.

**3.5.5.5** Test cores of approximately 2 inch (50 mm) diameter shall be taken by the Contractor through all concrete deposited underwater on rock. The cores shall penetrate a minimum of 1 ft (300 mm) into the rock. One core shall be taken near each corner and one shall be taken near the center. Should evidence of voids, seams or unsatisfactory concrete be discovered, additional cores shall be taken as ordered. Unsatisfactory material shall be removed and replaced or repaired as directed.

### **3.5.6 Substructure.**

**3.5.6.1** All substructure concrete shall be placed in the dry unless otherwise permitted. Footings shall be placed at the elevations shown on the plans or ordered.

### **3.5.7 Superstructure.**

**3.5.7.1** Compliance with superstructure concrete placing sequences shown on the plans will be mandatory unless prior approval is secured for an alternate sequence. If a pouring sequence is not shown, the Contractor shall submit his proposed pouring sequence for approval. Sufficient concrete placing units shall be furnished to maintain plasticity requirements. If there are multiple placements there shall be more than 72 hours between placements.

**3.5.7.2** Concrete operations on steel structures shall not start until all temporary falsework and bracing have been removed unless otherwise permitted.

### **3.5.8 Bridge Deck Overlays.**

**3.5.8.1 Surface Preparation.** The concrete deck shall be clean and free of laitance, oil, surface moisture, membrane residue, and other foreign materials. Abrasive blast cleaning may be required by the Engineer to achieve a suitable surface.

#### **3.5.8.2 Placing Bridge Deck Overlays.**

**3.5.8.2.1** Prior to placing of concrete the clean surface shall be thoroughly coated with bonding grout conforming to 2.9.2 herein.

**3.5.8.2.1.1** Care shall be exercised to ensure that all prepared surface areas receive a thorough, even coating, and that no excess bonding grout be permitted to collect in pockets.

**3.5.8.2.1.2** The grouting operation shall not advance more than 3 to 5 feet (1 to 2 meters) ahead of the placing of concrete, but not more than 10 minutes ahead of the finishing machine, unless otherwise directed. Concrete shall be placed while the slurry remains wet. Areas that have dried shall be thoroughly cleaned of all dry slurry and slurry shall be reapplied.

**3.5.8.2.1.3** Bonding grout that has dried, or become unworkable, as determined by the Engineer, shall not be incorporated in the work. No tempering will be permitted.

**3.5.8.2.2** Concrete placed in patches more than 1 inch deep shall be hand vibrated internally in addition to the surface vibration provided by the finishing machine.

**3.5.8.2.3** At transverse and longitudinal joints, the overlay course previously placed shall be sawn to a straight and vertical edge before the adjacent overlay course is placed.

**3.5.8.2.4** Bridge deck overlays shall not be placed when air or deck temperature is below 45 °F (7 °C). Decks may be placed when these temperatures are 45 °F (7 °C) and rising temperature is predicted.

**3.5.8.2.5** A construction dam or bulkhead shall be installed in case of major delay in the placement operation. During minor delays of one hour or less, the end of the placement may be protected from drying with several layers of wet burlap.

**3.5.8.2.6** Adequate precautions shall be taken to protect freshly placed concrete from sudden or unexpected rain. The Engineer may order removal of any material damaged by rainfall.

**3.5.8.3** Consolidation of bridge deck overlays shall be performed after the concrete has been screeded by the use of a separate, variable-speed vibrating pan attached to the finishing machine. Vibration shall be continuous until consolidation is achieved and stopped before segregation occurs or water is forced to exterior surfaces in appreciable amounts.

**3.5.8.3.1** Concrete shall not be placed at a rate greater than that which can be thoroughly consolidated by the vibrator in use.

**3.5.8.3.2** Hand vibrators shall be used adjacent to curbing and expansion joints whenever the machine vibrators cannot reach the areas.

**3.5.8.4** Curing of bridge deck overlays shall meet the requirements of 520.3.10.1 curing method "c". At temperatures below 55 °F (15 °C), the Engineer may require a longer curing period.

**3.5.8.4.1** Bridges may be opened to automobile traffic only after an initial curing, provided the required curing period has elapsed for all previously placed concrete patches.

### **3.5.9 Box Culverts.**

**3.5.9.1** Construction Joints shown on the plans or permitted shall be perpendicular to the base slab and normal to the culvert axis. Weepers and drains shall comply with 3.3.

## **3.6 Joints.**

### **3.6.1 General.**

**3.6.1.1** All joints not exposed to view in the final structure shall be waterproofed in accordance with 538.

### **3.6.2 Construction and Contraction Joints.**

**3.6.2.1** Joints shown on the plans or permitted shall be keyed, doweled, or both as shown or directed. Sizes and spacings shall be as shown or ordered. Horizontal joints will not be permitted unless shown on the plans or occasioned by breakdown of plant or equipment in which case, in addition to 3.5.3.1.3, planed lumber shall be inserted into the fresh concrete to produce a horizontal line in surfaces which will be exposed to view.

**3.6.2.2** When fresh concrete is to be bonded to previously placed concrete, the abutting surface shall be abraded by sandblasting and cleaned by compressed air. Immediately prior to placing concrete, the abutting surface shall be saturated with water meeting the requirements of 2.5.

## **SECTION 520**

**3.6.2.3** Where bonding is not desired, the existing concrete shall be coated with an approved form release compound before the adjacent concrete is placed.

### **3.6.3 Expansion Joints.**

**3.6.3.1** Expansion joints shall be constructed at the locations shown and in conformity with the details shown on the plans or ordered.

**3.6.3.2** Open joints shall be formed at the locations shown on the plans. Inserts shall be fabricated so as to permit removal without damage to the work.

## **3.7 Concreting in Cold Weather.**

### **3.7.1 General.**

**3.7.1.1** When the average daily temperature falls below 35 °F (2 °C) for more than 1 day, protective measures shall be taken to prevent damage to the concrete by freezing. The Contractor shall submit his proposed protective methods for approval. Concrete shall be protected from freezing for a minimum of 5 days. Concrete bridge decks shall not be placed without written permission.

### **3.7.2 Insulation.**

**3.7.2.1** Insulation shall be approved blanket, batt or board insulation with a thermal conductivity of less than 0.25 BTU per hour per square foot (0.8 W/m<sup>2</sup>) for a thermal gradient of 1 °F/inch (0.02 °C/mm).

**3.7.2.2** Concrete delivery temperature shall be 50 to 70 °F (10 to 20 °C) for sections 24 inch (600 mm) or less in thickness and 40 to 55 °F (5 to 15 °C) for sections thicker than 24 inch (600 mm) unless otherwise permitted.

### **3.7.3 Housing and Heating.**

**3.7.3.1** Housing for cold weather concreting shall consist of a framework covered with weathertight plastic or canvas and shall be large enough to completely enclose the work to be heated and to accommodate the required heating elements. Continuous maintenance and fire protection shall be provided.

**3.7.3.2** Heaters shall be of approved type and shall be furnished in sufficient quantity to maintain the required temperature without creating hot spots in the concrete.

### **3.7.4 Concrete.**

**3.7.4.1** Concrete shall be brought to the required temperature by the use of heated mixing water or heated aggregates or both. The maximum allowable temperature of water shall be 160 °F (70 °C) and the maximum allowable temperature for aggregates shall be 100 °F (40 °C). The heated water shall be added to the aggregates prior to the addition of the cement.

**3.7.4.2** Concrete delivery temperature shall be 50° to 70 °F (10° to 20 °C) for sections 24 inch (600 mm) or less in thickness and 40° to 55 °F (5° to 15 °C) for sections thicker than 24 inch (600 mm) unless otherwise permitted.

**3.7.4.3** If the air temperature and transporting distance prevent the delivery of the concrete at the required temperature without exceeding the maximum allowable temperature in 3.7.4.1, the placement shall be canceled until such time as the requirements can be met.

**3.7.4.4** Forms, reinforcing steel, existing concrete and all other materials which will be in contact with the fresh concrete shall be brought to a temperature of 50 °F (10 °C) and all frost shall be removed within the limits of the foundation prior to placing concrete.

**3.7.4.5** Concrete shall be placed in the forms as soon as possible after delivery and as rapidly as possible without exceeding form and tie capacities. Tarpaulins or other approved materials shall be used to cover the top openings in forms to prevent heat loss. Only that portion of the form required for placement shall be opened and the opening shall be recovered between trucks unless otherwise permitted.

**3.7.4.6** Finishing shall be completed as rapidly as possible. On areas where Item 534.3 is not used, liquid curing compound shall be applied to exposed surfaces immediately after finishing. After the concrete has set, plastic shall be placed over the exposed areas. When insulation is used, a covering of approved insulation or a layer of hay and a tarpaulin shall be placed over the plastic and secured in place.

**3.7.4.7** The concrete temperature shall be maintained between 50° and 100 °F (10 ° and 40 °C) for the first 72 hours and between 40° and 100 °F (4 ° and 40 °C) for the next 48 hours. The concrete shall then be permitted to cool at a rate not to exceed 1 °F (0.5 °C) per hour until it reaches the atmospheric temperature.

**3.7.4.8** During cold weather, cofferdams shall remain dewatered and the concrete kept from freezing for 24 hours following placing. After 24 hours, the Contractor may allow the cofferdam to flood.

### **3.8.1 General.**

**3.8.1.1** The Contractor shall maintain the as delivered concrete below 85 °F (30 °C). This may require the addition of ice to the mixing water, sprinkling the forms and reinforcing steel, scheduling the concrete placements for early morning or evening hours, or any other approved methods.

**3.8.1.2** After placement, the concrete shall be maintained below 100 °F (40 °C) by sunshades, windscreen, fog spray, wet burlap, or other approved methods.

**3.8.1.3** If excess water demand or too rapid setting is anticipated, a Water-Reducing or Retarding Admixture may be added to the mix in the amounts ordered.

**3.8.1.4** When daytime air temperatures exceed 85 °F (30 °C), concrete temperature exceeds 80 °F (25 °C), and in the opinion of the Engineer, satisfactory surface finish cannot be achieved, nighttime or early morning placement may be required. No additional compensation will be allowed for this work.

### **3.9 Finishing Plastic Concrete.**

#### **3.9.1 Surfaces Other Than Decks and Approach Slabs (at grade).**

**3.9.1.1** All upper horizontal surfaces such as the top of wings, bearing pedestals, and the like shall be finished by placing an excess of material in the forms and screeding off the excess after consolidation. The surface shall then be finished by the use of wood, magnesium, cork, canvas floats, or steel trowels as directed.

**3.9.1.2** Catwalks shall receive a magnesium float finish.

## SECTION 520

**3.9.1.3** Sidewalks shall receive a broom finish by lightly dragging a broom transversely across the finished concrete to roughen the surface unless otherwise directed. Surfaces beneath bridge rail posts, light pole bases, and the like shall not be broomed.

**3.9.1.4** All finishing shall be performed by persons experienced in the use of finishing equipment.

### **3.9.2 Concrete Decks and Approach Slabs (at grade).**

**3.9.2.1** All concrete decks shall be finished with the use of an approved self-propelled finishing machine with strike-off auger(s), capable of adjustment for crown and width, and capable of raising the screeds to clear the concrete when required unless specific written permission is given for an alternate method. Approach slabs (at grade) shall have the same finish requirements as concrete decks except that the finishing machine does not have to be self-propelled and equipped with auger(s).

**3.9.2.2** Screed rails shall be set and checked for the finishing machine to ride on. The rails shall have sufficient rigidity and support to prevent deflection. After the rails are set, the finishing machine shall be placed on the rails and operated over the entire deck as many times as necessary to assure the required depth of concrete and the proper clearances to the reinforcing steel prior to starting the placement.

**3.9.2.3** The finishing machine shall follow closely behind the placing and consolidating operation and the placing and finishing operations shall be continuous. See 3.5.3.1.2.1.

**3.9.2.4** All work behind the finishing machine shall be performed from work-bridges. Work-bridges shall have independent movement capability and shall not be attached to the finishing machine. Walking in the concrete behind the finishing machine will not be permitted.

**3.9.2.5** The finished concrete shall have the required crown and grade and the surface shall not vary from either by more than 1/8 inch in 10 ft (3 mm in 3 m). The surface shall have a concrete surface profile (CSP) of 5 or less in accordance with the International Concrete Repair Institute (ICRI) technical guideline for "Selecting and Specifying Concrete Surface Preparation for Sealers, Coatings, and Polymer Overlays" Guideline No. 03732. As soon as the bleeding has stopped or the sheen has started to disappear, the concrete shall be given a final surface finish by scraping or dragging with an approved float at least 3 ft (1.0 m) in length. The float shall be placed on the outer edge of the finished concrete and moved transversely the full width of the deck. The finished edge shall be parallel to centerline. Each subsequent pass shall lap the preceding pass by at least 1/2 the length of the float. Concrete decks that will be the final wearing surface shall receive a pan drag without a float finish. This shall be followed by a broom finish utilizing a broom specifically made for this purpose. Fabric impressions in the surface caused by the texture of water-retaining materials shall not be cause for rejection. Objectionable defects, such as sharp edges caused by cement cream lines or fabric creases, shall be removed by the Contractor.

### **3.10 Curing Concrete.**

**3.10.1** All exposed surfaces of concrete, except Class F, Flowable Fill, shall be cured in accordance with the requirements of Table 9. All water used to wet cure concrete shall conform to 2.5. Failure to cure concrete by an approved method shall be cause for rejecting the work.

TABLE 9 - CONCRETE CURING

Type of Construction	Curing Method	Minimum Number of Days Before Membrane Application	
		Horizontal per Section 538	Vertical per Section 538
Bridge Decks, approach slabs and overlays	c		
Concrete to be treated w/ Item 534 or 537	a		
All other concrete except Class F, Flowable Fill	a or b	14	7

Cure Method "a" - Concrete shall be kept moist until it can support curing covers at which time it shall be completely covered with a vapor-proof barrier conforming to 2.6.2. Water shall be reapplied as necessary to keep the surface of the concrete wet for the entire 7 day cure period.

Cure Method "b" - Immediately after finishing, all exposed surfaces shall be treated with a liquid curing compound conforming to 2.6.3 at the rate of 1 gallon per 200 square feet (2 liters per 10 square meters) or by fog spray, sprinkling or ponding of water conforming to 2.5 or any combination of the above, when the weather permits. Within 24 hours of finishing, these surfaces shall be completely covered with a vapor-proof barrier conforming to 2.6.2 for the remainder of the 7 days.

Cure Method "c" - The surface shall receive a wet cure utilizing water retaining material for at least 7 days. Water retaining material shall be burlap conforming to 2.6.1, cotton mats conforming to 2.6.4 or other approved water retaining material. Water retaining material shall be kept wet for the entire seven days. Apply water retaining material in accordance with 3.10.2. During the first 24 hours, the water retaining material shall be kept continuously wet by means of an approved automatic sprinkling or wetting system. After 24 hours, the Contractor may cover the wet water retaining material with a 4 mil (0.1 mm) minimum white polyethylene film for the remainder of the curing period in lieu of using a sprinkling or wetting system although wetting under the polyethylene may be required.

SECTION 520

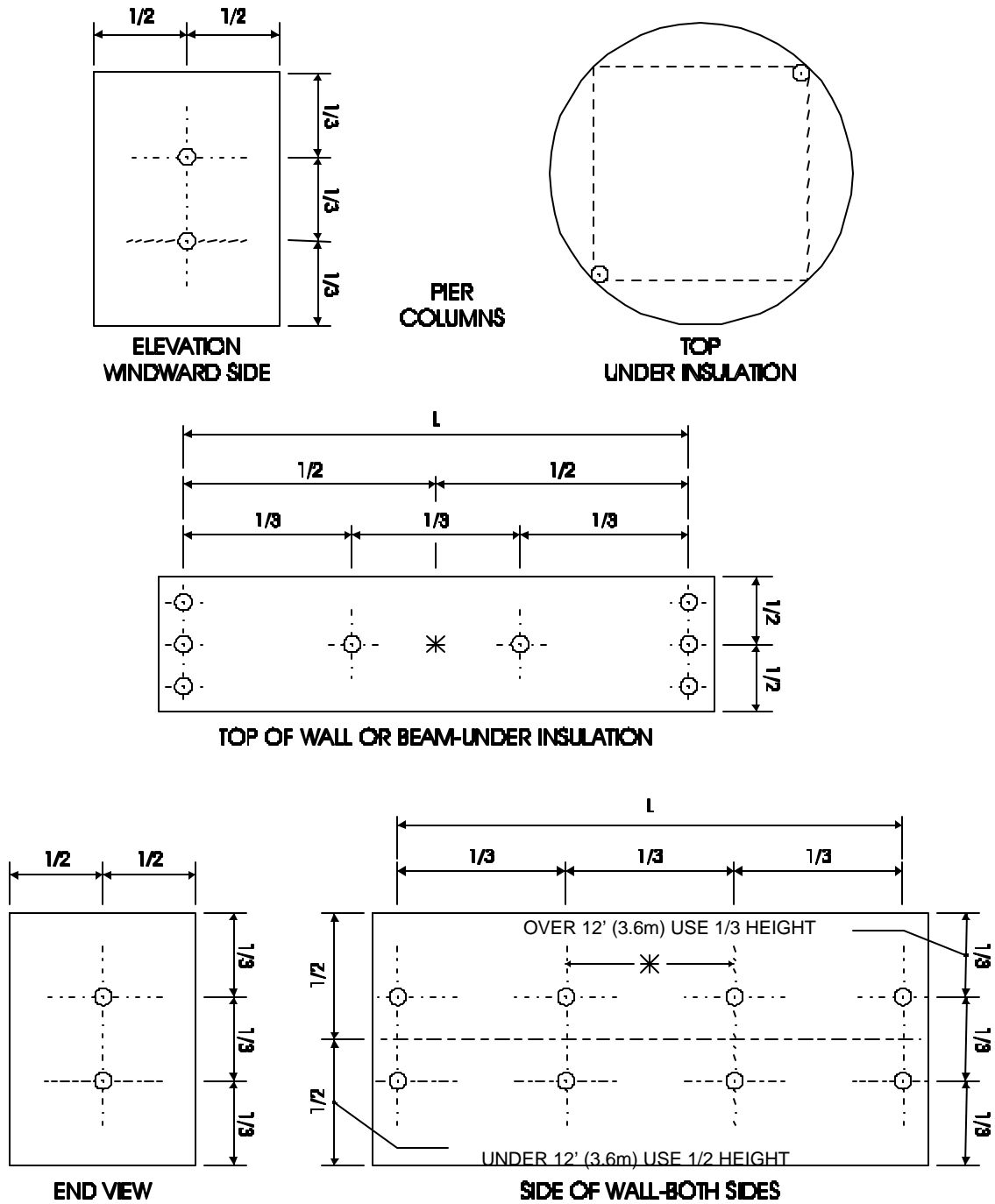

NOTE: WHEN "L" IS GREATER THAN 24 FEET (9 m), SPACING OF THERMOMETERS INDICATED BY (\*) TO BE APPROXIMATELY 8 FEET (3 M) LONGITUDINALLY.

THERMOMETER LOCATIONS

**FIGURE 3  
LOCATION OF THERMOMETERS**

**3.10.2 Application of Water Retaining Curing Material.**

**3.10.2.1** Burlap shall be applied damp within 30 minutes after concrete has been finished.

**3.10.2.2** Unsized cotton mats shall be applied dry within 10 minutes after concrete is finished and saturated immediately after. Care shall be exercised to ensure that the cotton mats are weighted down adequately to provide continuous contact with the concrete surface.

**3.10.2.3** Other approved water retaining curing material shall be applied in accordance with the manufacturer's recommendations and as approved by the Engineer.

**3.11 Loading Concrete.****3.11.1 Removing Forms**

**3.11.1.1** Unless otherwise permitted, load bearing forms may not be removed until concrete test cylinders have attained 80 percent of the specified design compressive strength. If not controlled by such tests, the following periods may be used as a guide: For load bearing falsework, 14 days; for all other parts, 3 days or as directed. Non-load bearing forms may be removed in order to finish the concrete surface following a minimum 24 hours cure time, when directed by the Engineer.

**3.11.1.2** The provisions of 3.10 shall apply if forms are removed prior to completion of the curing period.

**3.11.2 Loading Restrictions.**

**3.11.2.1** Nothing, except as permitted in 3.10.1, shall be placed on the concrete prior to the minimum time periods specified in Table 10.

**TABLE 10 - CONCRETE LOADING**

Type of Construction	Minimum Requirements before Loading after Placement of Concrete
Substructure concrete including footings	80% of design strength or 7 days
Box culvert base slabs	5 days
Superstructure concrete	1,800 psi – (15 Mpa) for curb placement; 80% of design strength for light vehicular loads when permitted 3,200 psi – (20 Mpa) for membrane and paving placement; and 4,000 psi – (30 Mpa) for legal traffic loads.

**3.11.2.2** The peak particle velocity ground vibration limits adjacent to newly placed concrete as specified in 203.3.2.5.1.5 shall apply.

**3.12 Finishing.****3.12.1 General.**

**3.12.1.1** Surface finishes shall be classified as follows:

- Class 1, Ordinary Finish
- Class 2, Rubbed Finish

## SECTION 520

**3.12.1.2.** Forms may be removed in accordance with 3.11.1.1. If the required curing period has not been completed for a surface being finished, only the portion of the surface actually being finished shall be exposed, and curing will be immediately re-established once the phase of finishing underway has been completed.

All exposed concrete surfaces shall be given a Class 1, Ordinary Finish. If a Class 2 or other finish is required, it shall be as specified by the Plans, Supplemental Specifications, or Special Provisions for designated surfaces.

**3.12.1.3 Class 1, ordinary finish.** Fins and projections shall be removed from all surfaces except those which will not be exposed. On all exposed surfaces the cavities produced by form ties, honeycomb spots, broken corners or edges, and all other holes and defects shall be thoroughly cleaned and saturated with water for not less than 3 hours. These areas shall then be carefully pointed and trued with a mortar composed of the same brand of cement and fine aggregate mixed in the proportions of the concrete being finished. Mortar used in pointing shall not be more than 1 hour old. The mortar patches shall be cured as specified in 3.10. All expansion joints in the completed work shall be left carefully tooled and free of mortar. The joint fillers shall be left exposed for their full length with clean, true edges. Holes which will not be exposed may be filled with asphalt cement when permitted.

**3.12.1.4 Class 2, rubbed finish.** After removal of forms, holes and imperfections shall be filled with mortar conforming to 3.12.1.3. After the mortar has thoroughly set, the concrete shall be saturated with water for at least 3 hours. The concrete shall be kept continuously wet at all times during finishing. The surfaces shall then be rubbed with a medium coarse Carborundum stone and a small amount of mortar until all voids have been filled and all marks and projections have been removed and the surface is uniform. This surface shall be left until all concrete to be rubbed above it has been similarly treated.

**3.12.1.4.1** After all concrete surfaces have received their initial rubbing, the next procedure shall consist of rubbing the concrete with fine Carborundum stone and water until a smooth uniform texture is obtained.

**3.12.1.4.2** The final procedure shall consist of rubbing the concrete with dry burlap to remove loose powder. Should the final surface be unsatisfactory, a repetition of the above procedures will be required. The final surface shall have been achieved by altering the original concrete surface; a surface coating of cementitious material which adds thickness to the original surface is not acceptable.

**3.12.1.5** All shrinkage cracks shall be treated as directed by the Engineer.

### **3.12.2 Method Requirements.**

**3.12.2.1** All copings shall receive a Class 2, Rubbed Finish. Exposed concrete surfaces containing imperfections shall be given a Class 2 finish or treated in some other manner approved by the Engineer. All other surfaces shall receive a Class 1 finish.

### **3.12.3 Performance Requirements (QC/QA).**

**3.12.3.1** All concrete copings and all other concrete surfaces shall receive a Class 1 finish unless otherwise specified.

## **Methods of Measurement**

**4.1** Concrete class AAA, AA, A, B, T and F will be measured by the cubic yard (cubic meter) in place unless otherwise indicated, and in accordance with the following.

## SECTION 520

**4.1.1** Except as specified below, the volume will be computed to the nearest 0.1 cubic yard (cubic meter) by the prismoidal method using the dimensions as shown on the plans or as ordered. No allowance or measurements will be made for materials not entering permanently into the work or those used without proper authorization. No deductions will be made for the volume of concrete displaced by steel reinforcement, structural steel, expansion joint materials, scuppers, weepers, conduits, or the tops of piles.

**4.1.1.1** Concrete Class T will be measured to the neat lines as shown on the plans. Seals on ledge will be measured to the ledge limit ordered to be removed.

**4.1.1.2** When the Engineer determines that it is impracticable to measure the volume by dimensions, the volume will be based on the actual yield as determined in the field in accordance with AASHTO T 121.

**4.1.1.3** Concrete Class B, footings (on rock) will be measured to the form lines placed at the limits shown on the plans. All concrete class B, footings (on rock) where rock will not be removed shall be formed and measured in accordance with 4.1.1.2.

**4.2** Concrete class AAA; AA; A, Above Footings; A, Culverts; B, Footings and concrete bridge deck of the type specified will not be measured, but shall be the cubic yard (cubic meter) final pay quantity in accordance with 109.11 for material required within the limits shown on the plans.

**4.3** Concrete for bridge deck overlay will be measured by the cubic yard (cubic meter) to the nearest 0.1 cubic yard (cubic meter) based on surface area multiplied by the specified depth.

### **Basis of Payment**

**5.1** The accepted quantities of concrete class AAA, AA, A, B, T and F will be paid for at the contract unit price per cubic yard (cubic meter) complete in place, unless otherwise indicated.

**5.1.1** The cost of development and testing of alternate mix designs for concrete class F, flowable fill will be subsidiary to the item.

**5.2** Concrete class AAA; AA; A, above footings; A, culverts; B, footings and concrete bridge deck of the type specified are final pay quantity items and will be paid for at the contract unit price per cubic yard (cubic meter) in accordance with 109.11.

### **5.3 Foundation Seal.**

**5.3.1** Seals shown on the plans will be paid for at the contract unit price per cubic yard (cubic meter) for 520.6.

**5.3.2** Seals ordered, but not shown on the plans, will be paid for at the contract unit price per cubic yard (cubic meter) for Class T concrete if Class T is included in the proposal.

**5.3.3** Seals requested by the Contractor and permitted, but not deemed necessary, will not be paid for.

**5.4** Waterproofing of construction joints shown on the plans or ordered will be paid for under 538.

**5.5** Waterstops will be paid for under 541.

**5.6** Reinforcing steel will be paid for under 544.

## SECTION 520

**5.7** Weepers and concrete admixtures will be subsidiary.

**5.8** The accepted quantity of concrete for bridge deck overlay will be paid for at the contract unit price per cubic yard (cubic meter) complete in place.

**5.8.1** Overlay materials rejected shall be removed and replaced by the Contractor at no additional cost to the Department.

**5.8.2** Saw cutting concrete for bridge deck overlays as required by 3.5.8.2.3 shall be subsidiary.

### **5.9 Performance Requirements – QC/QA Pay Adjustments.**

**5.9.1** Pay adjustments will be paid based on Unit Price (UP), pay adjustment factors as specified below, and the total quantity computed from all accepted delivery records. The UP will be the contract unit price per cubic yard (cubic meter) for the class of concrete involved. Where payment is on a final pay quantity basis, the UP for determining pay adjustments shall be determined by the following method. Multiply the Contract final pay quantity (adjusted Contract final pay quantity, if field changes have been made) by the unit price bid for the item, then divide the result by the total quantity computed from all accepted delivery records for the class of concrete being evaluated.

**5.9.1.1** For QC/QA Concrete Class A and Class B, no negative pay factors will be assessed when all test results meet the requirements for each class contained in section 520 of the Standard Specifications however, all provisions of 3.1.6.3.7.1 shall apply.

**5.9.1.2** The maximum and minimum percentage pay factors payable under this specification are as follows:

Class AA	+7%	to	-25%
Class A	+2%	to	-10%

**5.9.2** Concrete with non-conforming strength represented by an acceptance test per subplot will be subject to the following pay adjustment:

$$\text{Pay Factor (for strength in psi)} = 1 + 0.0005(f'_{ca} - f'_{c})$$

$$\text{Pay Factor (for strength in Mpa)} = 1 + 0.0725 (f'_{ca} - f'_{c})$$

Where  $f'_{ca}$  = actual compressive strength at 28 days  
 $f'_{c}$  = specified compressive strength at 28 days

$$\text{Sublot Pay Adjustment} = (\text{Pay Factor} - 1) \times \text{Sublot Size} \times \text{U.P.}$$

Concrete strength greater than the specified compressive strength is not eligible for bonus pay.

**5.9.3** Concrete with non-conforming rapid chloride permeability represented by a test value for the subplot greater than 4000 Coulombs up to and including 7000 Coulombs will be subject to the following pay adjustment:

The pay factor for rapid chloride permeability will be made in accordance with the following schedule rounded to 2 decimal places:

## Class AA

PERMEABILITY INDEX CHARGE PASSED (COULOMBS)	PAY FACTOR
> 0 and = 1000	1.05 - 0.00005 (1000 - C)
>1000 and = 3000	1.05
>3000 and = 4000	1 + 0.00005 (4000 - C)
>4000 and = 7000	1+0.0000833(4000-C)

**Sublot Pay Adjustment = (Pay Factor – 1) x Sublot Size x U.P.**

C = rapid chloride permeability in Coulombs

**5.9.3.1** When the rapid Chloride permeability for any sublot is greater than the upper specification limit as shown in Table 1, the concrete for that sublot will be rejected and subject to the provisions of 106.03.2.2.

**5.9.4** A pay factor each for air content and water cement ratio will be calculated in accordance with 106.03.2.4.

### 5.9.5 Concrete Cover

**5.9.5.1** For calculating the pay factor for concrete cover, measurements will be obtained from the GSSI SIR2 radar rebar depth measuring unit and recorded to the nearest 1/8 inch (millimeter). Each measurement will be converted into a number (x) that represents a percentage of the tolerance as listed in Table 1 with a negative number being below target value and a positive number being above target value. The following formula will be used for calculating each x value:

$$x = \frac{(R - TV)}{T}$$

where R = Result obtained from radar unit readings.  
 TV = Target value from Plans.  
 T = Tolerance from Table 1.

The x values over the entire lot will be evaluated together for a pay factor in accordance with 106.03.2.4 with USL = 1.00 and LSL = (-1.00).

**5.9.5.2 Bridge Decks.** In cases where the concrete cover is excessive such that the pay factor is calculated to be between 0.75 and 0.99 inclusive and the Lower Quality Index is 100%, the Contractor may submit calculations that show a live load rating greater than or equal to the design load for the deck. These calculations shall be based on the materials strengths stated in the plans, a "d" based on the 95<sup>th</sup> percentile cover measurement and shall follow an approved traditional method of analysis. If the calculations are accepted as correct by the Engineer, the negative pay adjustment for excess cover will be multiplied by 0.25. If the calculations are not accepted, all provisions of the specification regarding pay factors will remain in effect. If the concrete cover is excessive to the point where a failed condition results and all of the above conditions are met, the resultant pay factor shall be 0.93.

**5.9.5.3 Pedestrian Sidewalks.** In the case where concrete cover is excessive such that the pay factor is calculated to be less than 1.0 and the Lower Quality Index is 100%, the pay factor will be 1.0.

**5.9.5.4 At Grade Approach Slabs.** In cases where concrete cover is excessive such that the pay factor is calculated to be between 0.75 and 0.99 inclusive and the Lower Quality Index is 100%, the

**SECTION 520**

negative pay adjustment for excess cover will be multiplied by 0.25. If concrete cover is excessive to the point where a failed condition results and all of the above conditions are met, the resultant pay factor will be 0.93.

**5.9.5.5** Negative pay adjustments for concrete cover will be multiplied by 0.25 for decks constructed in phases and by 0.50 for rail support slabs. All provisions of 3.1.6.3.4.2 shall apply. Pay adjustment provisions for decks constructed in phases shall not be used in conjunction with pay adjustment provisions in 5.9.5.2. If concrete cover on decks constructed in phases is excessive to the point where a failed condition results, the resultant pay factor will be 0.93.

**5.9.6** Once the pay factor for permeability, air content, water cement ratio and concrete cover is determined, the following Table 11 and equations will be used to calculate an individual pay adjustment for each measured characteristic.

**Table 11 - Weight Factor**

MEASURED CHARACTERISTIC	WEIGHT FACTOR "f"		
	CLASS AA	CLASS A	CLASS B
Permeability	0.40	0.00	0.00
Air Content	0.40	0.40	0.20
Water/Cement Ratio	0.20	0.20 <sup>(1)</sup>	0.40 <sup>(1)</sup>
Concrete Cover	0.40	0.40 <sup>(1)</sup>	0.40 <sup>(1)</sup>

<sup>(1)</sup> This will be assigned a pay factor (PF) of 1.00

The pay adjustment for each measured characteristic per lot (per subplot for permeability) will be determined by the following equations:

For Pay Factors = 1.0:

$$PA_i = (Pf_i - 1)f_i(Q)(U.P.)$$

For Pay Factors < 1.0:

$$PA_i = (Pf_i - 1) \frac{f_i}{\sum f} (Q)(U.P.)$$

- where:
- PA<sub>i</sub> = Pay adjustment payment in dollars for each characteristic.
  - Pf<sub>i</sub> = Pay factor or composite pay factor for each characteristic.
  - f<sub>i</sub> = Weight factor from Table 6 for each characteristic.
  - ∑ f = Sum of weight factors.
  - Q = Quantity computed from all accepted delivery records for the lot (subplot for permeability).
  - U.P. = Unit price as defined in 5.9.1.

**SECTION 520**

**Pay items and units:**

520.__	Concrete Class __, _____ (F)*	Cubic Yard (Cubic Meter)
520.001	Concrete Class AAA	Cubic Yard (Cubic Meter)
520.__02	Concrete Class __, _____(QC/QA)(F)	Cubic Yard (Cubic Meter)
520.03	Concrete Class AA	Cubic Yard (Cubic Meter)
520.0202X	Concrete Class AA, <u>Rail Support Slab</u> (QC/QA) (F)	Cubic Yard (Cubic Meter)
520.12	Concrete Class A, Above Footings (F)	Cubic Yard (Cubic Meter)
520.211	Concrete Class B, Footings (On Rock)	Cubic Yard (Cubic Meter)
520.213	Concrete Class B, Footings (On Soil) (F)	Cubic Yard (Cubic Meter)
520.421	Concrete Class F, Flowable Fill, Excavatable	Cubic Yard (Cubic Meter)
520.6	Concrete Class T, Foundation Seal	Cubic Yard (Cubic Meter)
520.7	Concrete Bridge Deck (F)	Cubic Yard (Cubic Meter)
520.7X02	Concrete Bridge Deck (QC/QA)(F)	Cubic Yard (Cubic Meter)
1010.4X	Quality Control/Quality Assurance (QC/QA) for Concrete	\$

\* Some of these items may not be a final pay quantity item.

APPENDIX A

NHDOT MICROWAVE PROCEDURE  
FOR WATER/CEMENT RATIO

1. Tare microwave safe container
2. Place sample of 2000  $\pm$ 300 grams of concrete in container.
3. Weigh sample in container to nearest gram.
4. Place sample in container into microwave oven at 50% power for one half hour.
5. Weigh container and sample to nearest gram.
6. Place into microwave oven at 50% power for ten minutes.
7. Weigh to nearest gram.
8. Repeat steps 6 & 7 until constant weight is achieved.
9. Calculate Water/Cement (W/C) ratio with the following formula:

$$W/C = (N+1) MD - N \{ACA (1-FA) + AFA (FA)\}$$

Where: MD =  $\frac{WET\ WT. - DRY\ WT. (Concrete\ Sample)}{DRY\ WT.}$

N\* =  $\frac{TOTAL\ AGGREGATE}{CEMENT}$

FA\* = RATIO OF SAND TO TOTAL AGGREGATE (DECIMAL)

ACA = ABSORPTION OF COARSE AGGREGATE (DECIMAL)

AFA = ABSORPTION OF FINE AGGREGATE (DECIMAL)

\* Use Actual Batch Weights, not Mix Design

APPENDIX B

CONCRETE EVAPORATION RATE CHARTS

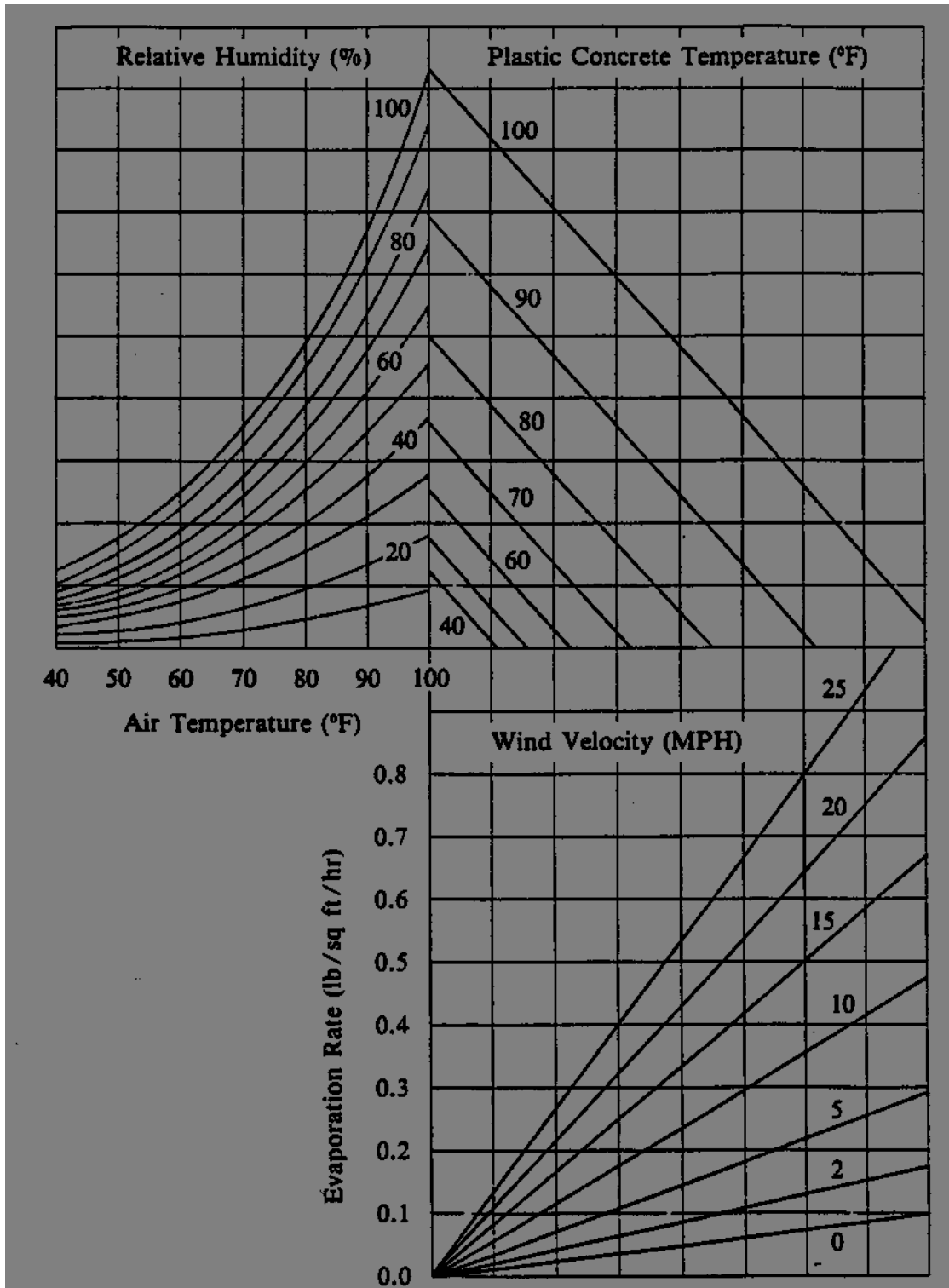

Chart 1 - Evaporation Rate (English)

SECTION 520

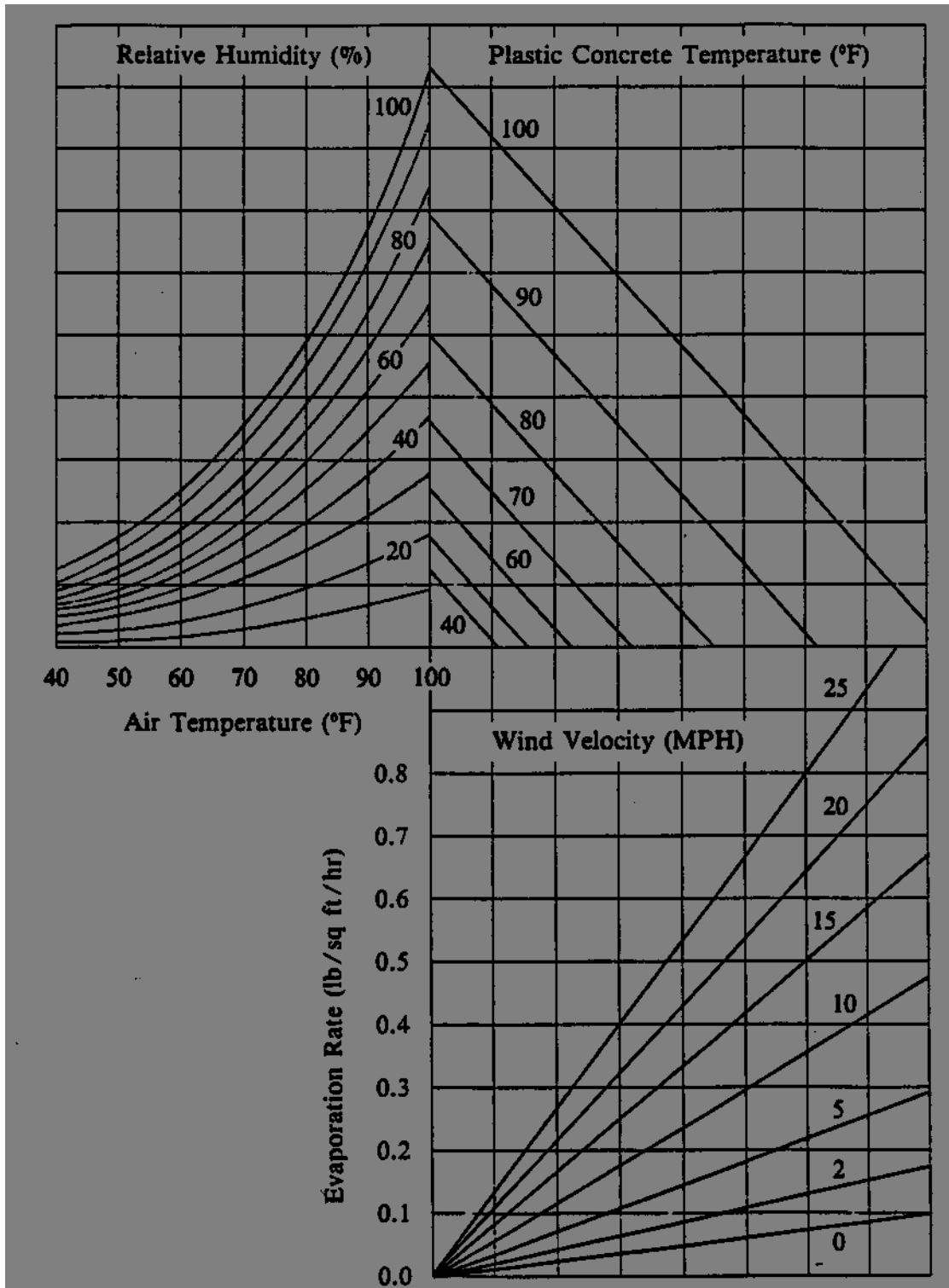

Chart 2 - Evaporation Rate (Metric)

**APPENDIX C**  
**EXAMPLE CALCULATIONS FOR PAY ADJUSTMENT (English version)**

**STEP 1 - STATEMENT OF CONDITIONS AND FIELD TEST RESULTS:**

- A) Bid price of the Concrete Class AA (QC/QA) item is \$373.89/CY, which is also the Unit Price of Concrete (see 520.5.2). The accepted quantity from the delivery records is 337 CY.
- B) All samples are to be taken on a statistically random basis with lot sizes based approximately on those values listed in the Acceptance Guidelines adjusted as required to meet field situations.

LOT	DATE	LOCATION	DAY'S PLACEMENT (CY)
1	June 15, 1998	Phase 1 Deck	162
2	June 25, 1998	Phase 1 Sidewalk	14
3	Aug. 25, 1998	Phase 2 Deck	148
4	Sept. 4, 1998	Phase 2 Sidewalk	13
			337

*Total =*

- C) **Strength.** Cylinder design strength is 4000 psi. Strengths will be the average of two cylinders per subplot broken at 28 days. The strength pay factor is not eligible for an incentive pay adjustment.

LOT	DAY'S PLACEMENT (CY)	SUBLOT NUMBER	SUBLOT SIZE (CY) (See 520.3.1.6.3.2)	CYLINDER STRENGTH (PSI)
1	162	1-1	54	7173
1		1-2	54	3770
1		1-3	54	7720
2	14	2-1	14	6970
3	148	3-1	49.33	5150
3		3-2	49.33	6260
3		3-3	49.34	3958
4	13	4-1	13	6580

- D) **Permeability.**

LOT	DAY'S PLACEMENT (CY)	SUBLOT NUMBER	SUBLOT SIZE (CY)	PERMEABILITY INDEX (Coulombs)
1	162	1-1	54	1503
1		1-2	54	1056
1		1-3	54	801
2	14	2-1	14	1321
3	148	3-1	49.33	987
3		3-2	49.33	1012
3		3-3	49.34	4806
4	13	4-1	13	5247

**SECTION 520**

**SECTION 520**

**E) Concrete air content.**

LOT	DAY'S PLACEMENT (CY)	SUBLOT NUMBER	SUBLOT SIZE (CY)	AIR CONTENT %
1	162	1-1	54	7.5
1		1-2	54	8.6
1		1-3	54	8.2
2	14	2-1	14	6.4
3	148	3-1	49.33	6.3
3		3-2	49.33	7.9
3		3-3	49.34	5.2
4	13	4-1	13	9.0

**F) Water/Cement ratio.**

LOT	DAYS PLACEMENT (CY)	SUBLOT NUMBER	SUBLOT SIZE (CY)	WATER/CEMENT RATIO
1	162	1-1	54	0.373
1		1-2	54	0.382
1		1-3	54	0.401
2	14	2-1	14	0.424
3	148	3-1	49.33	0.429
3		3-2	49.33	0.390
3		3-3	49.34	0.361
4	13	4-1	13	0.377

**G) Concrete cover.** Cover is measured according to the provisions of 520.5.9.5 from the concrete surface to the closest reinforcing member. Only 6 results shown for illustration purposes.

LOT	LOCATION(STA. TO STA.)	COVER (R)	VALUE (x)
3	Phase 2 Bridge Deck	2 1/4"	-0.50
		2 1/8"	-0.75
		2 1/2"	+0.00
		2 1/4"	-0.50
		2 5/8"	+0.25
		2 1/8"	-0.75

**SECTION 520**

**STEP 2 - CALCULATION OF PAY ADJUSTMENT**

A) **Strength Pay Adjustments:** Pay Factor (for strength in psi) = 0.0005 (f 'ca - f 'c)

LOT	SUBLOT NUMBER	CYLINDER STRENGTH f 'ca (PSI)	PAY FACTOR	SUBLOT SIZE (CY)	UNIT PRICE (\$/CY)	SUBLOT PAY ADJUST (\$) (PF x CY x UP)	CUMULATIVE ADJUST (\$)
1	1-1	7173	0.000	54	373.89	0.00	0.00
1	1-2	3770	-0.115	54	373.89	-2,321.86	-2,321.86
1	1-3	7720	0.000	54	373.89	0.00	-2,321.86
2	2-1	6970	0.000	14	373.89	0.00	-2,321.86
3	3-1	5150	0.000	49.33	373.89	0.00	-2,321.86
3	3-2	6260	0.000	49.33	373.89	0.00	-2,321.86
3	3-3	3958	0.000	49.34	373.89	0.00	-2,321.86
4	4-1	6580	0.000	13	373.89	0.00	-2,321.86

**COMMENTS:**

As per Section 520.3.1.6.3.7.1, sublots with test results that are within minus 60 psi of, or higher than, the design strength will not be pay adjusted, but will be paid for at 100% of the unit bid price. All concrete sublots with strengths of more than 500 psi below the mix design strength will be rejected by the Engineer.

Note that all values in the Lots, except one, are within the -60 psi limit

B) **Permeability Pay Adjustments:** See 5.9.3 for pay factor equations.

LOT	SUBLOT NUMBER	PERMEABILITY INDEX (Coulomb)	PAY FACTOR	SUBLOT SIZE (CY)	UNIT PRICE (\$/CY)	SUBLOT PAY ADJUST (\$) (See 5.9.6)	CUMULATIVE ADJUST (\$)
1	1-1	1503	1.05	54	373.89	\$403.80	\$403.80
1	1-2	1056	1.05	54	373.89	\$403.80	\$807.60
1	1-3	801	1.04	54	373.89	\$323.04	\$1,130.64
2	2-1	1321	1.05	14	373.89	\$104.69	\$1,235.33
3	3-1	987	1.05	49.33	373.89	\$368.88	\$1,604.21
3	3-2	1012	1.05	49.33	373.89	\$368.88	\$1,973.09
3	3-3	4806	0.93	49.34	373.89	-\$368.95	\$1604.14
4	4-1	5287	0.89	13	373.89	-\$152.76	\$1451.38

COMMENTS: As per 520.5.9.3 Pay Factors will be rounded to 2 decimal places.

**SECTION 520**

C) **Air Content Pay Adjustments:** Lot 2 result shall be evaluated with Lot 1 and Lot 4 shall be evaluated with Lot 3 per 520.3.1.6.3.2. See also 520.5.9.4 for pay factor formula.

LOT/ LOT SIZE	UPPER SPEC LIMIT (USL)(%)	LOWER SPEC LIMIT (LSL)(%)	SUBLOT TEST RESULTS				AVG (x)	STANDARD DEVIATION (s)
			1-1	1-2	1-3	2-1		
1 & 2								
176	9	5	7.5	8.6	8.2	6.4	7.675	0.964
3 & 4								
161	9	5	6.3	7.9	5.2	9.0	7.100	1.683

LOT	UPPER QUALITY INDEX (QU)	LOWER QUALITY INDEX (QL)	% WITHIN UPPER LIMITS (PU FROM TABLE 106-1, n=4)	% WITHIN LOWER LIMITS (PL FROM TABLE 106-1, n=4)	QUALITY LEVEL (QL)	PAY FACTOR (FROM TABLE 106-2)
1 & 2	1.37	2.77	96	100	96	1.04
3 & 4	1.13	1.25	88	92	80	1.02

Pay Adjustment (Lots 1 & 2) = (PF-1) x f x CY x UP = 0.04 x 0.40 x 176 x \$373.89 = \$1052.87

Pay Adjustment (Lots 3 & 4) = (PF-1) x f x CY x UP = 0.02 x 0.40 x 161x \$373.89 = \$481.57

D) **Water/Cement Ratio Pay Factor Determination:** USL is x+0.030 and LSL is x-0.030.

LOT/ LOT SIZE	UPPER SPEC LIMIT (USL)(%)	LOWER SPEC LIMIT (LSL)(%)	SUBLOT TEST RESULTS				AVG (x)	STANDARD DEVIATION (s)
			1-1	1-2	1-3	2-1		
1 & 2								
176	0.425	0.365	0.373	0.382	0.401	0.424	0.395	0.023
3 & 4								
161	0.419	0.359	0.429	0.390	0.361	0.377	0.389	0.029

LOT	UPPER QUALITY INDEX (QU)	LOWER QUALITY INDEX (QL)	% WITHIN UPPER LIMITS (PU FROM TABLE 106-1, n=4)	% WITHIN LOWER LIMITS (PL FROM TABLE 106-1, n=4)	QUALITY LEVEL (QL)	PAY FACTOR (FROM TABLE 106-2)
1 & 2	1.30	1.30	94	94	88	1.03
3 & 4	1.03	1.03	85	85	70	0.98

Pay Adjustment (Lots 1 & 2) = (PF-1) x f x CY x UP = 0.03 x 0.20 x 176 x \$373.89 = \$394.83

Pay Adjustment (Lots 3 & 4) = (PF-1) x f x CY x UP = -0.02 x 0.20 x 161x \$373.89 = -\$240.79

E) **Concrete Cover Pay Factor Determination:** See 520.5.9.5. Assume for this example 450 readings were taken from the phase 1 deck and sidewalk surfaces with an overall x value of -0.30 and a standard deviation of 0.411 as determined by the radar depth measuring unit.

**SECTION 520**

LOT	LOT SIZE	UPPER SPEC LIMIT (USL)	LOWER SPEC LIMIT (LSL)	AVG (x)	STANDARD DEVIATION (s)
1&2	450	1.00	-1.00	-0.30	0.411

UPPER QUALITY INDEX (QU)	LOWER QUALITY INDEX (QL)	% WITHIN UPPER LIMITS (PU FROM TABLE 106-1, n>200)	% WITHIN LOWER LIMITS (PL FROM TABLE 106-1, n>200)	QUALITY LEVEL (QL)	PAY FACTOR (FROM TABLE 106-2)
3.16	1.70	100	96	96	1.02

Pay Adjustment (Lots 1&2) = UP x (PF-1) x CY x f = \$373.89 x 0.02 x 176 x 0.40 = \$526.44  
 Assume that the phase 2 deck and associated sidewalk yield a 0.99 pay factor:

Pay Adjustment (Lots 3&4) = UP x (PF-1) x CY x f = \$373.89 x -0.01 x 161 x 0.40 = -\$240.79

**STEP 3 – TOTAL PAY ADJUSTMENT:**

Strength Pay Adjustment	-\$2,321.86
Permeability Pay Adjustment	\$1451.38
Air Content Pay Adjustment (Lots 1&2)	\$1,052.87
Air Content Pay Adjustment (Lots 3&4)	\$481.57
Water/Cement Ratio Pay Adjustment (Lots 1&2)	\$394.83
Water/Cement Ratio Pay Adjustment (Lots 3&4)	-\$240.79
Concrete Cover Pay Adjustment (Lots 1&2)	\$526.44
Concrete Cover Pay Adjustment (Lots 3&4)	-\$240.79
<b>Total Class AA Pay Adjustment (Item 1010.4X) =</b>	<b>\$1,103.65</b>

NOTE: Pay adjustments may be calculated for each estimate based on all test results to date.

ROUNDING NOTE: Target values and results are rounded to the same places as the specification.  
 Average (x) and standard deviation (s) are not rounded.  
 Pay factors,  $Q_U$ , and  $Q_L$  are rounded to 2 places in all cases.

**SECTION 528 -- PRESTRESSED CONCRETE MEMBERS**

DESCRIPTION	275
MATERIALS	276
2.1	CEMENT.....276
2.2	AGGREGATE.....276
2.3	ADMIXTURES.....276
2.4	PRESTRESSING STEEL.....276
2.5	REINFORCING STEEL.....276
2.6	WIRE FABRIC.....276
2.8	CONCRETE.....276
2.9	SHEAR KEY GROUT FOR BUTTED BEAMS.....277
CONSTRUCTION REQUIREMENTS	278
3.1	GENERAL.....278
3.2	QUALIFICATION OF THE FABRICATOR.....280
3.3	ALTERNATE STRAND PATTERNS.....280
3.4	SHOP DRAWINGS.....281
3.5	SHOP INSPECTION.....281
3.6	STRESSING EQUIPMENT.....282
3.7	PLACEMENT AND STRESSING OF STRANDS.....282
3.8	DEBONDING.....283
3.9	FORMS.....283
3.10	MIXING OF CONCRETE.....283
3.11	PLACEMENT OF CONCRETE.....283
3.12	CONSOLIDATION OF CONCRETE.....284
3.13	ROUGHNESS OF TOP SURFACE OF MEMBER.....284
3.14	CURING.....284
3.15	RELEASE OF PRESTRESS.....285
3.16	STRIPPING FORMS AND FINISH OF MEMBER.....285
3.17	DAMAGE/CRACKING.....286
3.18	PATCHING.....286
3.19	DIMENSIONAL TOLERANCES.....287
3.20	HANDLING AND STORING.....287
3.21	SHIPPING.....288
3.22	ERECTION OF PRESTRESSED CONCRETE MEMBERS.....288
METHOD OF MEASUREMENT	289
BASIS OF PAYMENT	289
APPENDIX A	290
APPENDIX B	291
APPENDIX C	292
APPENDIX D	293

**Description**

**1.1** This work shall consist of manufacturing, storing, transporting, and erecting, precast, pretensioned, concrete I-girders, bulb-tee girders, box beams, butted deck beams, and deck panels herein referred to as “members”, in accordance with the Contract plans. The relevant provisions of the AASHTO Standard

## SECTION 528

Specifications for Highway Bridges shall be adhered to unless such provisions are in conflict with this specification. This specification includes provisions for high performance concrete and alkali-silica reactivity.

**1.1.1** This work shall also include the installation of grout and the application of transverse post-tensioning where indicated on the plans.

### Materials

**2.1 Cement.** Portland cement shall be Type II or III conforming to AASHTO M 85 or M 240, as appropriate.

**2.1.1** All cement used in the manufacture of the members in any one structure shall be the same brand, type and color, unless otherwise permitted.

**2.2 Aggregate.** Aggregate shall conform to the requirements of 520.2.2. The coarse aggregate gradation shall be as specified for Concrete Class AA in 520.

**2.3 Admixtures.** Admixtures shall conform to the requirements of 520.2.3.

### 2.4 Prestressing Steel.

**2.4.1** Prestressing steel shall be uncoated, seven-wire strand, conforming to the requirements of AASHTO M 203/M 203M Grade 1860 (270) low-relaxation.

**2.4.2** The Fabricator shall furnish certified copies of a representative load-elongation curve test report for each size and grade of strand, for lots of 10 tons (9 metric tons) or fraction thereof.

**2.4.3** The Fabricator shall furnish a certified mill test report for each heat and coil of wire used in the production of the strand.

**2.4.4** Each manufactured reel of prestressing steel strand to be shipped shall be assigned an individual lot number and clearly tagged for accurate identification. Such identification shall not be removed from the reel or strand until the reel is entirely used or until end-use fabrication has been completed.

**2.5 Reinforcing steel.** Reinforcing steel shall conform to the requirements of 544.2.

**2.6 Wire Fabric.** Welded deformed steel wire fabric shall conform to the requirements of AASHTO M 221M/M 221.

**2.7** Storage of concrete materials shall conform to the requirements of 520.2.10.

### 2.8 Concrete

**2.8.1** Concrete shall be controlled, mixed, and handled as specified in the pertinent portions of 520 unless otherwise specified herein.

**2.8.2 Mix Design.** The Fabricator shall design and submit for approval the proportions and test results for a concrete mix which shall attain the following: a minimum design compressive strength as detailed on the plans for test cylinders sampled in accordance with the requirements of AASHTO T 141, molded and cured in accordance with the requirements of AASHTO T 23, and tested in accordance with the requirements of AASHTO T 22; a rapid chloride ion permeability of 2500 Coulombs or less measured at 56 days using AASHTO T 277. The minimum average compressive strength of the proposed mix shall be determined using

the procedures in Appendix D. Air entrainment shall be targeted at a value of 5 percent with an absolute minimum of 3.5 percent required. Testing shall be in accordance with AASHTO T 119 and T 152. The absolute minimum air requirement shall only be permitted for members that have decks or other overpours with a minimum thickness of 7 in (175 mm) or more.

**2.8.2.1** Sixty (60) days prior to the start of member fabrication, the mix design shall be submitted to the Bureau of Materials and Research for approval. No concrete shall be placed within the forms until the concrete mix design is approved.

**2.8.2.2** The Fabricator shall supply laboratory test reports that contain data on the mineralogy and potential reactivity for all aggregates being used in the concrete mix. All aggregates shall be tested in accordance with the requirements of AASHTO T 303 to determine alkali-silica reactivity. The laboratory supplying the test results shall provide evidence that the laboratory is properly equipped and qualified to perform the test methods. All test results submitted for alkali-silica reactivity shall be from tests conducted within one calendar year from the date the mix design is submitted to the Department.

**2.8.2.3** Mix designs using potentially alkali reactive aggregates shall include mitigation for reactivity and shall be submitted to the Department for approval. Mitigation of potentially reactive aggregates shall consist of one or more of the following methods: use of low alkali cement (less than 0.6 percent Na<sub>2</sub>O equivalent); use of a mineral admixture; or use of a chemical admixture. The proposed mitigation method will be accepted for use after the NHDOT Bureau of Materials and Research reviews test results supplied by the Contractor that show the effectiveness of the mitigation. An effective mitigation technique should reduce the mean expansion to below 0.10% for alkali-silica reactivity when tested in accordance with AASHTO T303.

**2.8.2.4** Should a change in sources of material be made, a new mix design shall be established and approved prior to incorporating the new material. When unsatisfactory results or other conditions make it necessary, the Engineer will require a new mix design.

**2.8.3** All concrete used in precast prestressed members shall contain corrosion inhibitor as shown on the Department's Qualified Products List. Corrosion inhibitor shall be used at the rate recommended by the manufacturer.

## **2.9 Shear Key Grout for Butted Beams.**

**2.9.1** Grout for shear keys shall be an approved grout as listed under Section 529A of the Qualified Products List. Additional aggregates shall not be added to the material during field mixing.

**2.9.2** The average compressive strength of the 3 cubes at 7 days shall be a minimum of 6000 psi (40 Mpa). When tested, 3 neat two in (50 mm) cubes shall be molded and cured in accordance with AASHTO T 106 (ASTM C 109).

**2.9.3** The grout when thoroughly mixed shall be readily pourable so that it completely fills the shape of the shear key joint.

**2.9.4** The Contractor shall submit a premixed name brand to the Engineer for approval.

**2.10** Temporary supports/grout dams for precast deck panels shall consist of continuous, high-density, expanded polystyrene strips (grout dam) with a minimum compressive strength of 55 psi (380 Pa). If leveling screws are used, a 1.7 pound per cubic foot (27.2 kg per cubic meter) polyethylene foam seal shall be used as a grout dam.

## SECTION 528

### Construction Requirements

#### 3.1 General.

**3.1.1** Design stresses are closely controlled, however, the behavior in service depends upon the specified concrete being properly placed in forms of the correct dimensions around accurately positioned prestressed strand.

**3.1.2 Specifications.** Fabrication, transportation and erection of prestressed concrete members shall conform to the requirements of the AASHTO Standard Specifications for Highway Bridges, Division II, Section 8-Concrete Structures and Section 10-Prestressing, and PCI MNL-116, Manual for Quality Control for Plants and Production of Precast and Prestressed Concrete Products, except as modified by this special provision. In the case of conflicting specifications, the most stringent shall apply.

**3.1.3 Approval.** Prior to performing any work under 528, the Contractor must have received approval for all shop drawings and any special Contract requirements. The Contractor shall bear full responsibility and costs for all materials ordered or work performed prior to approval of the shop drawings or written authorization from the Engineer.

#### 3.1.4 Special Contract Requirements.

**3.1.4.1 Pre-Placement Meeting.** At the request of the Engineer, a pre-placement meeting will be scheduled to review the specification, the schedule, and discuss any special requirements. The meeting will be held at least forty-five (45) days prior to the scheduled casting of any member or test section. The Contract Administrator shall schedule the meeting and invite representatives of the Contractor, Fabricator and the Bureaus of Bridge Design and Materials and Research, along with any other party the Engineer deems appropriate.

**3.1.4.2 Sure Cure System.** The Fabricator shall utilize the Sure Cure Cylinder Mould System, or approved equivalent system, to temperature match cure test cylinders sampled in accordance with AASHTO T 141, molded in accordance with AASHTO T 23 and tested in accordance with AASHTO T 22 for use in verifying concrete compressive strength at release ( $f'_{ci}$ ), design compressive strength ( $f'_{c}$ ) for acceptance and concrete permeability in all member types. Verification that the system is operating properly shall be supplied to the Department once every 12 months. Documentation shall confirm that the system heats the molds only when they are colder than the internal girder temperature.

**3.1.4.2.1** Match cured cylinders shall be produced using the sure cure system. The cylinders shall be connected to the system's temperature matching controller for the initial curing period. Once the members are stripped and detensioned or the test section stripped, the cylinders shall be subsequently stripped from their molds and stored alongside the member or the test section until they are scheduled to be tested.

**3.1.4.2.2** The system's reference thermocouple shall be located in the center of the bottom bulb of the girder section, or as otherwise directed by the Engineer in other member types. The thermocouple extension wire shall protrude up out of the member and shall be connected to the system's temperature matching controller.

Thermocouples shall be placed as follows:

For members longer than 50 feet (15 m) in length, one thermocouple shall be placed in each member cast. For members less than 50 feet (15 m) in length, one thermocouple shall be placed in each 12 cy (9 m<sup>3</sup>) of product. (i.e. 3 thermocouples shall be installed for a placement with 30 cy of concrete) A minimum of 1 thermocouple shall be placed in each bed cast.

**3.1.4.3 Test Section.**

**3.1.4.3.1** At least thirty (30) days prior to member fabrication, a test placement [10 feet (3 meters) in length] of the actual member section (unreinforced) shall be poured utilizing the proposed methods of concrete placement and curing. The air entrainment target value of 5 percent shall be held as an absolute minimum value for the test section. Concrete not meeting the air content target value shall not be incorporated into the test placement. Slump as required per 2.8.2 shall be maintained.

**3.1.4.3.2** The Fabricator shall submit to the Bureau of Materials & Research results of temperature match cured cylinders (a set of two, averaged to comprise one strength test) tested for strength at the following intervals as a minimum (15 hours, 24 hours, 3 days, 7 days, and 28 days) for determination of a strength versus time plot for the test placement section.

**3.1.4.3.3** The Fabricator shall obtain two cores in accordance with AASHTO T 24 from the web of the girder test section, or other location determined by the Engineer, and test them for design compressive strength at 28 days (or other time interval to attain design compressive strength as detailed on the plans) to verify the in place concrete strength of the test section. The cores shall be taken no earlier than two days prior to conducting the actual test. Results of the core strength tests shall be submitted to the Bureau of Materials & Research.

**3.1.4.3.4** Rapid Chloride Permeability testing may be completed by the Bureau of Materials & Research in accordance with AASHTO T 277 at an age of 56 days or later. The Fabricator shall obtain two additional cores from the web of the girder test section and submit the cores to the Bureau of Materials & Research for permeability testing. The Fabricator shall also submit two additional match cured cylinders from the test placement to the Bureau of Materials & Research for permeability testing.

**3.1.4.3.5** Approval to proceed to member fabrication will be provided by the Bureau of Materials & Research and shall be contingent on successfully achieving the minimum design compressive strength in each of the match cured cylinders and cores tested at 28 days. If unsatisfactory results occur or conditions arise to hinder the outcome of the tests, the Engineer will require a new test section placement, with modifications as deemed necessary, to be poured and successfully tested.

**3.1.4.3.6 Test Section Exemption.** Fabricators having proven experience with the mix design submitted for use, in precast/prestressed bridge member applications, shall be exempt from the test section placement, as approved by the Department. Proven experience will be determined by the Bureau of Materials and Research based on submission of satisfactory test results using a particular mix design that meets or exceeds the following criteria in a similar fabricated bridge member or a similar 10 foot long bridge member test section:

- Compressive Strength (as specified in 3.1.4.3.5)
- Rapid chloride ion permeability (as specified in 2.8.2)
- Air content (as specified in 3.1.4.3.1 or higher)
- Slump of the concrete (as specified in 2.8.2)

Approval to proceed to member fabrication will be provided by the Bureau of Materials and Research and shall be contingent on review and approval of the submitted test results.

**3.1.5 Member Concrete Strength Testing.**

**3.1.5.1** The Fabricator shall submit to the Bureau of Materials & Research results of temperature match cured cylinders (a set of two, averaged to comprise one strength test) tested for compressive strength at

## SECTION 528

release and design compressive strength at 28 days (or other time interval to attain design compressive strength detailed) for each bed cast.

**3.1.5.2** Each member cast shall have a minimum of two additional match cured cylinders for each thermocouple used available for testing by the Department at 28 days (or other time interval to attain design compressive strength detailed) for quality assurance. Acceptance of the concrete within each member will be based on successfully achieving a minimum average design compressive strength for two match cured quality assurance cylinders.

### **3.1.6 Member Concrete Permeability Testing.**

**3.1.6.1** Rapid Chloride Permeability testing may be completed on all members types by the Bureau of Materials & Research in accordance with AASHTO T 277 at an age of 56 days or later. The Fabricator shall submit two match cured cylinders from each bed cast to the Bureau of Materials & Research for permeability testing.

**3.1.6.2** Acceptance of the concrete within each bed cast will be based on successfully achieving the maximum average rapid chloride permeability value of 2500 coulombs at 56 days for two match cured quality assurance cylinders.

## **3.2 Qualification of the Fabricator.**

**3.2.1 Minimum Requirements.** All plants/shops fabricating material for the Department shall satisfy the following minimum requirements:

**3.2.1.1 Certification.** The precast concrete manufacturing plant shall be certified by the Prestressed Concrete Institute Plant Certification Program. The Fabricator shall submit proof of certification prior to the start of production.

Certification shall be as follows:

For deck panels, certification shall be category B2 or higher.

For straight strand members, certification shall be category B3 or higher.

For draped strand members, certification shall be in category B4.

**3.2.1.2 Engineering/Drafting.** The Fabricator shall have trained, knowledgeable, and experienced drafting personnel available who can produce and check legible, complete, and accurate shop detail drawings.

**3.2.1.3 Specifications.** The Fabricator shall have available in the shop all pertinent specifications governing the work.

**3.2.1.4 Technician.** The Fabricator shall provide a technician having at least 5 years continuous experience in the manufacture of prestressed members, who shall supervise the work.

**3.2.2 Quality Control.** The Fabricator shall perform quality control functions to insure that the product is fabricated in accordance with Contract documents and specifications.

**3.3 Alternate Strand Patterns .** The use of alternate strand patterns are subject to the approval of the Bureau of Bridge Design. The design of debonded strand patterns are subject to the requirements listed in Appendix C of this specification.

**3.3.1 Changes to the eccentricity** of the prestressing force at any location within the member shall have the following additional requirements. Upon approval, plans with details showing the proposed changes shall be submitted for inclusion into the Plans on file in the Bridge Design office. The plans shall include the

State's standard border and title box and shall be on archival quality, 22 in x 34 in (560 x 860 mm) double matte mylar. The plans shall include member sections and strand eccentricities at appropriate locations, a member elevation showing proposed changes (draping, debonding, mild reinforcement, etc.) and other pertinent information resulting from changes in the design. The plans shall be stamped by a Licensed Professional Engineer licensed in the State of NH. The design calculations and load rating form (Form 4) shall be submitted for documentation and stamped by a Licensed Professional Engineer licensed in the State of NH.

### **3.4 Shop Drawings.**

**3.4.1** The Contractor shall prepare and submit shop details, and all other necessary working drawings for approval in accordance with the requirements of 105.02. The Contractor shall submit six copies of the shop drawings for approval.

**3.4.2** Fabrication shall not begin until written approval of the submitted shop drawings has been received from the Engineer.

**3.4.3** Deviation from the approved shop drawings will not be permitted without written order or approval of the Engineer.

**3.4.4 Tracings.** Original tracings of all corrected shop drawings shall be delivered to the Department before final payment will be made.

### **3.5 Shop Inspection.**

**3.5.1 Inspection.** A Department Representative will inspect the fabrication of the members for quality assurance. This inspection will include the examination of materials, work procedures, and the final fabricated product.

**3.5.1.1** Fabrication shall only be done in the presence of an authorized inspector representing the Department. The Department's authorized quality assurance inspector is herein referred to as the "Inspector".

**3.5.2 Notice.** At least fourteen (14) days prior to the scheduled start of casting on any member or test section, the Fabricator shall contact the Department's Bureau of Materials and Research to provide notice of the scheduled start date. The Bureau of Materials and Research will assign an Inspector to the scheduled work to provide quality assurance testing. The Inspector will coordinate directly with the Fabricator to determine the casting schedule.

**3.5.2.1** In addition to the requirements of 3.5.2, the Fabricator shall contact the Bureau of Materials and Research at least two (2) days before the actual work begins to allow scheduling of independent assurance testing by the Bureau.

**3.5.3 Authority.** The Inspector shall have the authority to reject any material or workmanship that does not meet the requirements of the Contract documents.

**3.5.3.1** Inspection at the shop is intended as a means of facilitating the work and avoiding errors. It does not constitute final approval and will not relieve the Contractor from any responsibility in regard to imperfect material or workmanship and the necessity for replacing same.

**3.5.4 Acceptance.** The Inspector shall affix an acceptance stamp to members ready for shipment. This mark shall be made by paint or ink stamp in a location that will not be visible when the structure is completed.

## SECTION 528

**3.5.4.1** The Fabricator shall present the Inspector with a copy of the shipping invoice to be stamped for verification of inspection and approval prior to shipment.

**3.5.4.2** The Inspector's acceptance implies that, in the opinion of the Inspectors the members were fabricated from accepted materials and processes and loaded for shipment in accordance with the Contract requirements. The Inspector's stamp of acceptance for shipment does not imply that the members will not be rejected by the Engineer if subsequently found to be defective.

**3.5.5 Cooperation.** The Fabricator shall fully cooperate with the Inspector in the inspection of the work in progress.

**3.5.5.1** The Fabricator shall allow the Inspector unrestricted access to the necessary areas of the shop during work hours. Work done while the Inspector has been refused access shall be automatically rejected.

### **3.6 Stressing Equipment.**

**3.6.1** Prestressing shall be done with approved hydraulic jacking equipment.

**3.6.2** Hydraulic jacks shall be equipped with accurately reading pressure gauges. The combination of jack and gauge shall be calibrated and a certified graph or table showing the calibration shall be submitted to the Engineer. The calibration date shall be within a 12-month period immediately prior to the start of work.

### **3.7 Placement and Stressing of Strands.**

**3.7.1** Prestressing strands shall be accurately placed to achieve the center of gravity of the strand as shown on the approved shop drawings. Strands shall be protected against corrosion and free of nicks, kinks, dirt, rust, oil, grease, and other deleterious substances.

**3.7.2** Layers of strands shall be separated by steel supports in accordance with the Concrete Reinforcing Steel Institute Manual of Standard Practice and shall be of approved shape and dimension. Suitable horizontal and vertical spacers shall be provided, if required, to keep the strands in true position in the forms. Hold-down devices used at all points of change in slope of the strands shall be of approved low-friction type.

**3.7.3** Prior to stressing, the Fabricator shall submit for approval the computations of the proposed gauge pressure, elongations of the prestressing strands (allowing for losses), and the sequence of operations. A record shall be kept of the gauge pressure and the elongation produced thereby for each strand. Complete and accurate records of each stressing operation shall be submitted to the Engineer.

**3.7.4** The mild reinforcing steel shall be placed in position after the stressing is performed unless otherwise approved.

**3.7.5** Each strand shall be stretched initially to a minimum gauge pull to eliminate all slack and equalize the stresses in the strands as determined by the Engineer before starting elongation measurements. All strands shall be in position before the stressing operation is begun.

**3.7.6** Stressing shall be performed by either simultaneous or individual application of tension to the strands. The amount of stress to be applied to each strand and the sequence of stressing shall be as shown on the plans and approved shop drawings. Stressing shall be performed only in the presence of the Inspector.

**3.7.7 Safety Measures.** Safety measures must be taken by the Fabricator to prevent accidents due to possible breaking of the prestressing strand or the slipping of the grips during the prestressing process.

**3.7.8** Several members may be cast in a continuous line and stressed at one time. Sufficient space shall be maintained between ends of members to permit access for cutting strands after the concrete has attained the required strength.

**3.8 Debonding** of the prestressing strands, if required, shall be accomplished by the use of sheathing. Sheaths shall be of an approved material which is watertight, has sufficient strength to withstand concrete placement and does not react with concrete or steel. Sheaths shall be properly sealed to prevent intrusion of cement paste during concrete placement.

### **3.9 Forms.**

**3.9.1** Forms shall be subject to the approval of the Engineer.

**3.9.2** Forms shall be made and maintained true to the shapes and dimensions shown on the plans.

**3.9.3** The surface of forms shall be smooth, and if necessary, joints shall be treated so that a minimum of joint marks are evident in the finished member.

**3.9.4** Forms shall be constructed and end bearing plates placed so as to allow for any shortening of the member due to compressive stresses resulting from transfer of stress and from shrinkage.

**3.9.5** Side forms shall be of steel and shall be supported without resort to ties or spreaders within the body of the member. They shall be braced and stiffened so that no deflection or curvature occurs during concrete placement.

**3.9.6** Forms shall be cleaned before each use.

### **3.10 Mixing of Concrete.**

**3.10.1** Proportioning and batching of concrete shall conform to 520.3.1 or as ordered.

### **3.11 Placement of Concrete.**

**3.11.1** Concrete shall not be deposited in the forms until the Inspector has approved the placement of the reinforcing and prestressing strands. Concrete shall be deposited only in the presence of the Inspector and in accordance with 520.3.5.

**3.11.1.1 Cold Weather.** When the average daily temperature falls below 35 °F (2 °C) for more than 1 day, protective measures shall be taken to prevent damage to the concrete by freezing. The protective measures shall be included on the shop drawings as required.

**3.11.2** All reinforcing and strands shall be free of dirt, rust, oil, grease, and other deleterious substances.

**3.11.3** All items encased in the concrete shall be accurately placed in the position shown on the plans and firmly held during the placing and setting of the concrete. Clearance from the forms shall be maintained by supports, spacers, or hangers in accordance with 544.3.4 and shall be of approved shape and dimension.

**3.11.4** The details of all inserts, anchors, and any other items required to be cast into the members (whether detailed on the contract drawings or provided for the Contractor's convenience) shall be shown on the shop drawings. Members shall not be fired or drilled into for attachment purposes. All hardware shall be galvanized except as otherwise noted.

## SECTION 528

**3.11.5** The temperature of the concrete shall not exceed 90 °F (30 °C) when placed in the forms.

**3.11.6** Placement of concrete in stages to facilitate box beam fabrication will be allowed. Interval times between concrete placement stages shall be limited to 45 minutes to ensure that a cold joint has not formed between the two placement stages. Placement plans requiring interval times longer than 45 minutes shall be approved prior to use. Interval times extending beyond 45 minutes without prior approval is cause for rejection of the member.

### **3.12 Consolidation of Concrete.**

**3.12.1** Consolidation of concrete shall conform to 520.3.5.4 or as ordered.

**3.12.2** The vibrating shall be done with care and in such manner as to avoid displacement of reinforcing, strands, shoes, or other inserts.

**3.12.3** The size of the vibrator spud shall be proper for the size of the openings available.

**3.12.4** External vibration will be permitted.

### **3.13 Roughness of Top Surface of Member.**

**3.13.1** The top surface of all members shall be finished true by striking off at the top of the forms. A flattened area of sufficient size (4 in by 4 in +/-) shall be provided at the centerline of bearing and tenth points on tops of all the girders to facilitate taking elevations for measuring camber and deflection. These areas shall be steel trowel finished with a maximum difference in elevation between the high to low spots being less than 1/8 in (3 mm).

**3.13.2** As soon as conditions permit, before the concrete has fully hardened, all dirt, laitance, and loose aggregate shall be removed from the top surface. The top surface shall be finished as shown on the plans.

**3.13.2.1** The top surface of precast prestressed deck panels shall be roughened with a broom finish.

### **3.14 Curing.**

**3.14.1 General.** The Contractor shall indicate on the shop drawings, for approval, the method of cure and a complete outline of the proposed procedure. The Contractor may choose one of the following curing methods.

- a. Saturated Cover
- b. Low Pressure Steam

**3.14.1.1 Saturated Cover.** Each unit shall be immediately covered with heavy, water saturated burlap, or other material acceptable to the Inspector. The burlap shall be kept saturated, and the concrete surface temperature shall not drop below 68 °F (20°C). These conditions shall be maintained for a minimum of three days or until the concrete has reached release strength.

**3.14.1.2 Steam Curing.** Live steam shall be introduced into the enclosure through a series of steam jets which shall be evenly spaced within the enclosure. The initial set of the concrete shall take place before steam is introduced. The enclosure shall be at 100% relative humidity to prevent loss of moisture to ensure proper hydration of the cement. The steam curing cycle shall include a gradual heating and cooling period during which the rate of change in temperature shall not exceed 68 °F (20 °C) per hour. The maximum temperature inside the enclosure shall not exceed 160 °F (70 °C). After the concrete has reached specified

release strength, the temperature within the curing enclosure shall be decreased at an average rate not exceeding 68 °F (20 °C) per hour until the temperature within the curing enclosure is within 50 °F (10 °C) of the ambient temperature of the storage area.

**3.14.1.3** The maximum concrete temperature within the member shall be less than 160 °F (70 °C).

**3.14.2 Record of Curing Time and Temperature.** The Fabricator shall provide one (1) automatic temperature recorder for every 100 ft (30 meters) of member. The recorder shall continuously record curing temperatures while the member is curing. The sensors shall be carefully placed to ensure that ambient conditions are measured. Recorder accuracy shall be certified once every 12 months and the certificate displayed with each recorder. In addition, random temperature checks of each recorder shall be made by the Inspector.

Each chart shall indicate the casting bed, date of casting, time of commencing, graphic plot and the units that are represented by the chart. The start of artificial heat (if steam cured) and the transfer of prestress shall be indicated on each graphic record.

When curing is complete, the charts shall be properly marked and given to the Quality Assurance Inspector. Temperatures recorded on the charts shall be considered as verification of whether the units have been cured in accordance with the approved shop drawings.

### **3.15 Release of Prestress.**

**3.15.1** A detensioning sequence shall be submitted with the shop drawings on a separate 8 1/2" x 11" sheet. The proposed sequence is for informational purposes and will be used only as a reference for the inspector during fabrication.

**3.15.2** Detensioning shall not commence until the concrete has attained a compressive strength of at least 4000 psi (27.5 Mpa) (or the release strength indicated on the plans) as shown by match cured test cylinders. Detensioning shall be done at approximately equal concrete strengths for all members. The temperature of match cured cylinders used for determination of adequate release strength shall be controlled by a thermocouple located in the last member cast in each bed.

**3.15.3** Detensioning shall be accomplished by a gradual release of jack pressure, or by cutting individual strands in an approved sequence. If detensioning is accomplished by single strand release, each strand shall be cut by gradually heating the strand at both ends of the member simultaneously. A minimum length of 5 in (125 mm) of strand shall be heated to prevent any shock or snap when the strand is finally severed. Each strand shall be cut at all spaces between members when cast continuously before starting detensioning on the following strand in the sequence. All detensioning shall be performed in the presence of the Inspector.

**3.15.4** If the concrete has been heat-cured, detensioning shall be performed immediately following the curing period while the concrete is still warm and moist.

**3.15.5** Detensioning shall be kept symmetrical about the axes of the member and in the sequence submitted as part of the shop drawings.

**3.15.6** Forms, or any device which restricts either horizontal or vertical movement of the member, shall be stripped or loosened prior to detensioning.

### **3.16 Stripping Forms and Finish of Member.**

**3.16.1** No forms shall be removed without approval. Proper care and precautions shall be exercised in removing forms so that no damage results to finished surfaces.

## SECTION 528

**3.16.2** The member shall receive a Class 1, Ordinary Finish in accordance with 520.3.12 except patching shall be in accordance with 3.18.

**3.16.3** The shear key joints at the sides of butted beams shall be abrasive blast-cleaned prior to shipping.

**3.16.4 Finish of Strands.** At the ends of simple span members and the free ends of members made continuous, all strands shall be recessed. Each recess shall be 1 1/2 in (40 mm) square and 3/4 in (20 mm) deep. Projecting strands shall be burned out unless specified otherwise on the plans and the recess cleaned prior to patching with an approved material. The entire end cross-section shall then be coated with an approved bitumastic material.

**3.16.5 Finish of Strands for Deck Panels.** At the ends of deck panels strands shall have a minimum extension of 4 in (100 mm) beyond each end of the panel.

**3.17 Damage/Cracking.** The PCI New England Region Bridge Member Repair Guidelines, Report Number PCINER-01-BMRG shall be used in conjunction with this specification to help identify damage, determine the potential cause and appropriate repair procedure if warranted.

**3.17.1 Precast Concrete Deck Panels.** Detensioning procedures causing member cracking shall be revised before detensioning the next bed. A revised detensioning sequence shall be submitted for review as in 3.15.1.

**3.17.1.1 Rejection.** Any of the following conditions will be cause for rejection of prestressed deck panels:

- 1) Any crack transverse or diagonal to the strand pattern and crossing more than one strand
- 2) Any crack parallel to a strand and longer than 1/3 of the panel length
- 3) Cracks shorter than 1/3 of the panel length and present at more than 12% of the total number of strands in the panel
- 4) Voids or honeycombed areas with exposed strands

Deck Panels with cracks or with damage less severe than the conditions stated above shall be repaired by the Contractor using an approved procedure, at no cost to the Department.

**3.17.2 Other Members.** Detensioning procedures causing web splitting or other member cracking shall be revised before detensioning the next bed. A revised detensioning sequence shall be submitted as in 3.15.1. Cracks less than 0.01 in (0.25 mm) in width shall be sealed by an approved method. Cracks in excess of 0.01 in (0.25 mm) may be cause for rejection. Cracked members shall be repaired or replaced by the Contractor at the Department's direction at no cost to the Department.

### **3.18 Patching.**

**3.18.1** Patching of any surface irregularities, especially those resulting from honey-combing, shall be done only after inspection for determination as to whether or not the work is acceptable.

**3.18.2** When patching is allowed, it shall be done within 24 hours after stripping, and the patching shall be damp-cured for not less than a 3-day period and kept from freezing for the following 3 days.

**3.18.3** Patching of damaged members in lieu of required replacement will not be permitted.

**3.19 Dimensional Tolerances.**

**3.19.1** All tolerances not specified otherwise, shall be in accordance with PCI MNL -116 “Manual for Quality Control for Plants and Production of Precast and Prestressed Concrete Products” except as modified herein.

**3.19.2** Camber shall be measured at consistent times within 24 hours after transfer of prestress.

**3.19.3 Dimensional Tolerances of Deck Panels.** Panels shall be manufactured in conformity with the following tolerances:

<b>Depth of panel</b>	-1/8, +1/4 in (-3 mm, +6 mm)
Width of panel	+/-1/4 in (+/-6 mm)
Length of panel	+/-1/4 in (+/-6 mm)
Squareness (Difference between lengths measured along diagonals)	1/2 in (12 mm) (max.)
Vertical position of strand group (Measured from bottom of panel)	+0, -1/8 in (+0, -3 mm)
Vertical position of individual strands	+/- 1/8 in (+/-3 mm)
Horizontal strand position	+/-1/4 in (+/-6 mm)
Strand projection	+/- 1/2 in (+/- 12 mm)
Bowing	+/-1/8 in (+/-3 mm)
Dunnage	+/- 6 in (+/- 150 mm)
Warping	1/16 in per foot (5 mm per meter) of distance from nearest adjacent corner

**3.20 Handling and Storing.**

**3.20.1** Members damaged during handling and storage will be repaired or replaced at the Department’s direction at no cost to the Department.

**3.20.2** Members shall be lifted at the designated points by approved lifting devices embedded in the concrete and proper hoisting procedures.

**3.20.3** The points of support and the direction of the reactions with respect to the member during handling and storage shall be approximately the same as when the member is in its final position. Members shall be stored plumb.

**3.20.4** Storage areas shall be smooth and well compacted to prevent damage due to differential settlement. Stacks of members may be supported on the ground by means of continuous blocking located perpendicular to the strands at the ends. Intermediate blocking between members shall be located directly over the blocking below.

**3.20.4.1** Members shall be protected from freezing temperatures 32 °F, (0 °C) for 5 days or until attaining design compressive strength detailed on the plans, whichever comes first.

**3.20.5** Members may be loaded on a trailer as described above. Shock-absorbing cushioning material shall be used at all bearing points during transportation of the members. Tie-down straps shall be located at the lines of blocking only.

## SECTION 528

**3.20.6** The members shall not be subject to damaging torsional or impact stresses.

**3.20.7** Panels stored prior to shipment shall be inspected by the Contractor prior to being delivered to the site to identify damage that would be cause for repair or rejection. The Contractor shall ensure that sufficient acceptable panels are available for anticipated placement so that unacceptable delays to the project completion can be avoided.

**3.21 Shipping.** A member shall not be transported from the casting yard until the minimum 28 day compressive strength stated in 3.1.5 has been attained as shown by test cylinders cured according to 3.1.4.2 , and a minimum of 7 days has elapsed from casting of the member.

### **3.22 Erection of Prestressed Concrete Members.**

**3.22.1 Delivery and Field Inspection.** Material, workmanship and condition after shipment will be inspected after delivery to the construction site, with this and any previous inspections constituting only partial acceptance.

**3.22.1.1** All work of handling, assembling and erecting the members shall be subject to the inspection and approval of the Engineer, who shall be furnished with necessary facilities, including scaffolding and supports, to provide access to the structure to allow for inspection of workmanship.

**3.22.2 Erection Plans.** Before starting the work of erecting the members the Contractor shall submit an erection plan for documentation in accordance with 105.02. The erection plan shall describe the method of erection proposed and the amount and character of equipment proposed.

**3.22.3 Temporary Bracing for Girders.** After a girder has been erected, temporary braces shall be provided as necessary to resist wind and other loads. Details of temporary bracing shall be provided as part of the erection plans.

**3.22.4 Bearings.** Bearings shall be installed in accordance with 548.

**3.22.5 Sequence of Construction for Butted Beams.** The installation of the butted beams shall be in accordance with 528, Appendix A or B as appropriate.

### **3.22.6 Installation of Deck Panels.**

**3.22.6.1** Panels shall be installed as shown on the plans. The temporary supports shall be attached to the top flange of the girder with an approved adhesive in accordance with the Manufacturer's recommendations. The temporary supports shall be cut in the field to the required height after the blocking depth has been determined.

**3.22.6.2** Multiple panels shall not be stacked on a panel after it has been placed on the temporary supports without the approval of the Engineer.

**3.22.6.3** Panels shall not be used to support heavy loads until the top slab is cast and cured. Construction loads on individual panels shall be uniformly applied and shall not exceed an average loading of approximately 40 pounds per square ft (2000 Pa).

**3.22.6.4** After the panels have been placed on the temporary supports, the area under the ends of the panels and over the girder flanges up to the bottom of the panels shall be completely filled with Concrete Class AA, Including High Range Water Reducing Admixture as shown on the plans. The concrete shall cure a minimum of three (3) days prior to placing the concrete deck. If leveling screws are used, they shall be completely removed and the holes filled with grout prior to the placement of deck concrete.

**3.22.6.5** Prior to placement of the deck concrete, laitance or other contaminants that would interfere with full bond to the panels shall be removed by an approved method.

#### Method of Measurement

**4.1** Prestressed concrete girders will not be measured, but shall be the linear foot (linear meter) final pay quantities in accordance with 109.11 for material required with the limits shown on the plans.

**4.2** Prestressed concrete bridge deck will not be measured, but shall be the square foot (square meter) final pay quantities in accordance with 109.11 for material required with the limits shown on the plans.

**4.3** Prestressed concrete deck panels will not be measured, but shall be the square foot (square meter) final pay quantities in accordance with 109.11 for material required with the limits shown on the plans.

#### Basis of Payment

**5.1** Prestressed concrete girders are a final pay quantity item and will be paid for at the contract unit price per linear foot (linear meter) complete in place in accordance with 109.11.

**5.1.1** Test sections (if required) will be paid for as extra work in accordance with 109.04.

**5.2** Prestressed concrete bridge deck members are a final pay quantity item and will be paid for at the contract unit price per square foot (square meter) complete in place in accordance with 109.11.

**5.3** Prestressed concrete deck panels are a final pay quantity item and will be paid for at the contract unit price per square foot (square meter) complete in place in accordance with 109.11.

#### Pay items and unit:

528.1110	Prestressed Concrete Girders, NEBT 1000 (F)	Linear Foot (Linear Meter)
528.1112	Prestressed Concrete Girders, NEBT 1200 (F)	Linear Foot (Linear Meter)
528.1114	Prestressed Concrete Girders, NEBT 1400 (F)	Linear Foot (Linear Meter)
528.1116	Prestressed Concrete Girders, NEBT 1600 (F)	Linear Foot (Linear Meter)
528.1118	Prestressed Concrete Girders, NEBT 1800 (F)	Linear Foot (Linear Meter)
528.12__	Prestressed Concrete Girders, Spread Box Beams (F)	Linear Foot (Linear Meter)
528.31__	Prestressed Concrete Bridge Deck, Butted Deck Beams (F)	Square Foot (Square Meter)
528.32__	Prestressed Concrete Bridge Deck, Butted Box Beams (F)	Square Foot (Square Meter)
528.5__	Prestressed Concrete Deck Panels (F)	Square Foot (Square Meter)

## SECTION 528

### APPENDIX A SEQUENCE OF CONSTRUCTION FOR BUTTED BOX AND BUTTED DECK BEAM SUPERSTRUCTURES (SKEWS $\leq 30^\circ$ )

#### A) Layout Working Lines

- Working lines shall be laid out on the beam seat for the entire width of the bridge. All working lines are to be measured from a common working point.
- The working lines are to be based on the nominal beam widths.

#### B) Verify Beam Seat Elevations

- Take elevations at beam seats
- If seats are high, grind to correct elevations.
- If seats are low, shim as required. Shims to be high durometer neoprene or high density plastic.
- Install bearing pads.

#### C) Erect Beams

- Pressure wash sides of beams.
- Beams shall be placed to fit within the working lines.
- As work progresses, install hardwood wedges between adjacent beams to maintain proper shear key joint opening. Install a minimum of one wedge at each transverse tie location.

#### D) Install Polyethylene Closed Cell Backer Rod as Joint Filler at Shear Key Locations.

- Filler shall be placed below the bottom of the shear key joints as shown on the Plans and shall conform to key depth change in configuration at the transverse tie locations. Filler shall be installed sufficiently tight to prevent loss of the shear key grout.

#### E) Install Transverse Ties

- Feed transverse ties through ducts.
- Verify that hardwood wedges are in place as required to prevent slippage of beams.
- Using a calibrated jack, post-tension transverse ties to approximately 5,000 lbs. to remove sag in the tie and to seat the chuck.
- For stage construction, the second stage transverse tie ducts shall be protected at the shear key joints by installing second stage transverse ties or placing styrofoam over the duct opening.

#### F) Grout Shear Key

A correctly grouted shear key joint is necessary to ensure the structural integrity of the superstructure.

- Clean the shear key joint with an oil free air-blast immediately prior to grout placement. Verify that the backer rod is still in place.
- Additional shear key joint preparation and grout placement shall be per the Manufacturer's recommendations.
- Shear key joints shall be carefully rodded to eliminate voids.

#### G) Post-Tension Transverse Ties

- Shear key grout shall attain a minimum compressive strength of 1500 psi, based on the Manufacturer's recommendations, prior to stressing.
- Using a calibrated jack operated by qualified personnel, post-tension transverse ties to 30,000 lbs. beginning with inner most ties and proceeding symmetrically about mid-span towards the member ends. Inner ties shall be re-checked to ensure that the ties have 30,000 lbs. of tension. (For box beams with top and bottom transverse ties: tension the bottom tie to 15,000 lbs. then tension the top tie to 15,000 lbs. Repeat the sequence once more so that each transverse tie has 30,000 lbs. of tension.)

#### H) Finish Work

- Remove wedges and patch the deck and fascia beams at transverse tie locations.
- Place abutment concrete above the beam seat construction joint.
- Place brush curb and overlay concrete.

**APPENDIX B  
SEQUENCE OF CONSTRUCTION  
FOR  
BUTTED BOX AND BUTTED DECK BEAM SUPERSTRUCTURES  
(STITCHED CONSTRUCTION SKEWS > 30°)**

- A) Layout Working Lines**
- Working lines shall be laid out on the beam seat for the entire width of the bridge. All working lines are to be measured from a common working point.
  - The working lines are to be based on the nominal beam widths.
- B) Verify Beam Seat Elevations**
- Take elevations at beam seats
  - If seats are high, grind to correct elevations.
  - If seats are low, shim as required. Shims to be high durometer neoprene or high density plastic.
  - Install bearing pads.
- C) Erect Beams**
- Pressure wash sides of beams.
  - Beams shall be placed to fit within the working lines.
  - Each beam is erected with a preset dead-end chuck and transverse tie in place. As each beam is erected, the live end of the transverse tie from the preceding beam is worked through the duct.
  - Install hardwood wedges between adjacent beams to maintain proper shear key joint opening. Install a minimum of two wedges at each transverse tie location, one on top and the other under the beam.
  - Using a calibrated jack operated by qualified personnel, post-tension transverse ties to 30,000 lbs. (For box beams with top and bottom transverse ties: tension the bottom tie to 15,000 lbs. then tension the top tie to 15,000 lbs. Repeat the sequence once more so that each transverse tie has 30,000 lbs. of tension)
  - Repeat above steps until all beams are erected.
- D) Install Polyethylene Closed Cell Backer Rod as Joint Filler at Shear Key Locations.**
- Filler shall be placed below the bottom of the shear key joints as shown on the Plans. Care shall be used to seal the joint under the transverse tie and maintain the proper shape of the key at all transverse tie locations. Filler shall be installed sufficiently tight to prevent the loss of the shear key grout.
- E) Grout Shear Key**
- A correctly grouted shear key joint is necessary to ensure the structural integrity of the superstructure.
- Clean the shear key joint with an oil free air-blast immediately prior to grout placement. Verify that the backer rod is still in place.
  - Additional shear key joint preparation and grout placement shall be per the Manufacturer's recommendations.
  - Shear key joints shall be carefully rodded to eliminate voids.
- F) Finish Work**
- Remove wedges, and patch the deck and fascia beams at transverse tie locations.
  - Place abutment concrete above the beam seat construction joint.
  - Place brush curb and overlay concrete.

## SECTION 528

### APPENDIX C DESIGN REQUIREMENTS FOR PARTIALLY DEBONDED STRANDS

The use of partially debonded strands shall be subject to the following requirements:

1. The number of debonded strands shall not exceed 25% of the total number of strands.
2. The number of debonded strands in any horizontal row shall not exceed 40% of the strands in that row.
3. Center to center spacing between debonded strands in a horizontal row shall be 4 in (100 mm) or greater.
4. Exterior strands in each horizontal row shall be fully bonded.
5. Debonded strands shall be placed in pairs, symmetrically distributed about the centerline of the member, within the same row. The debonded length of a pair of strands shall be equal.
6. Debonded lengths of strand shall be staggered. No two pairs shall have the same debonded length and debonded lengths shall differ by at least 1 foot.
7. Debonded lengths at each end of the member shall be limited to 15% of the member length.

**APPENDIX D**  
**ALTERNATE METHOD FOR THE CALCULATION**  
**OF THE REQUIRED AVERAGE COMPRESSIVE STRENGTH**  
**FOR THE MIX DESIGN**

**1) Standard Deviation**

- 1.1) A standard deviation shall be established from test records of the mix design. Test records from which a standard deviation is calculated:
- a) Shall represent materials, quality control procedures, and conditions similar to those expected and changes in materials and proportions within the test records shall not have been more restricted than those for proposed work.
  - b) Shall represent concrete produced to meet a specified strength or strengths  $f'c$  within 1000 psi of that specified for proposed work.
  - c) Shall consist of at least 30 consecutive tests or two groups of consecutive tests totaling at least 30 tests except as provided in (1.2). A strength test shall be the average of the strength of two cylinders made from the same sample of concrete and tested at 28 days.
- 1.2) Where a concrete production facility does not have test records meeting requirements of (1.1), but does have a record based on 15 to 29 consecutive tests, a standard deviation shall be established as the product of the calculated standard deviation and modification factor of Table 1. To be acceptable, test records shall meet requirements (a) and (b) of (1.1), and represent only a single record of consecutive tests that span a period of not less than 45 calendar days.
- 1.3) Calculation of Standard Deviation

When a concrete production facility has a suitable record of 30 consecutive tests of similar materials and conditions expected, the standard deviation is calculated from those results in accordance with the following formula:

$$s = \left( \frac{\sum (X_i - \bar{X})^2}{n - 1} \right)^{1/2} \quad \text{EQ. 1}$$

where:

$s$  = standard deviation, psi

$X_i$  = individual strength tests

$\bar{X}$  = average of  $n$  strength test results

$n$  = number of consecutive strength tests

The standard deviation is used to determine the average strength required in (2.1).

## SECTION 528

If two test records are used to obtain at least 30 tests, the standard deviation used shall be the statistical average of the values calculated from each test record in accordance with the following formula:

$$\bar{s} = \left( \frac{n_1 - 1)(s_1)^2 + (n_2 - 1)(s_2)^2}{n_1 + n_2 - 2} \right)^{1/2} \quad \text{EQ. 2}$$

where

$\bar{s}$  = statistical average standard deviation where two test records are used to estimate the standard deviation

$s_1, s_2$  = standard deviations calculated from two test records, 1 and 2, respectively

$n_1, n_2$  = number of tests in each test record, respectively

If less than 30, but at least 15 tests are available, the calculated standard deviation is increased by the factor given Table 1.

**TABLE 1 - MODIFICATION FACTOR FOR STANDARD DEVIATION WHEN LESS THAN 30 TESTS ARE AVAILABLE**

No. of tests*	Modification factor for standard deviation†
less than 15	Use Table 2
15	1.16
20	1.08
25	1.03
30 or more	1.00

\* Interpolate for intermediate numbers of tests.

† Modified standard deviation to be used to determine required average strength  $f'_{cr}$  from (2.1).

### 2) Required average strength

2.1 Required average compressive strength  $f'_{cr}$  used as the basis for selection of concrete proportions shall be the larger of EQ. (3) or EQ (4) using a standard deviation calculated in accordance with (1).

$$f'_{cr} = f'_c + 1.34s \quad \text{EQ. 3}$$

or

$$f'_{cr} = f'_c + 2.33s - 500 \quad \text{EQ. 4}$$

$s$  shall be computed accordingly to 1.3.

$f'_c$  = specified compressive strength of concrete, psi

$f'_{cr}$  = required average compressive strength of concrete for mix design, psi

**2.2** When a concrete production facility does not have field strength test records for calculation of standard deviation meeting requirements of (1), required average strength  $f'_{cr}$  shall be determined from Table 2 and documentation of average strength shall be in accordance with requirements of (3).

**TABLE 2 - REQUIRED AVERAGE COMPRESSIVE STRENGTH WHEN DATA ARE NOT AVAILABLE TO ESTABLISH A STANDARD DEVIATION**

Specified compressive strength $f'_c$ , psi	Required average compressive strength $f'_{cr}$ psi
Less than 3000 psi	$f'_c + 1000$
3000 to 5000	$f'_c + 1200$
Over 5000	$f'_c + 1400$

**3) Documentation of average strength**

Documentation that proposed concrete proportions will produce an average compressive strength equal to or greater than required average compressive strength calculated in accordance with (2), shall consist of a field strength test records, several strength test records, or trial mixtures.

**SECTION 530 -- WATERPROOFING CONCRETE SURFACES**

**Description**

**1.1** This work shall consist of waterproofing concrete surfaces shown on the plans or ordered with two coats of a cement base waterproof coating for concrete.

**Materials**

- 2.1** All components of this system shall be compatible and shall be furnished by the same supplier.
- 2.2** All materials shall be delivered to the job site in sealed containers bearing the manufacturer's original labels.
- 2.3** The color when dry shall be a shade of gray matching the concrete.
- 2.4** Materials used for this specification shall be a product as included on the Qualified Products List.
- 2.5** The mixture shall not contain calcium chloride or sodium chloride.

**Construction Requirements**

**3.1 Preparation of Surfaces.**

**3.1.1** The concrete face to be coated shall be cleaned of all laitance, dirt, dust, oil, efflorescence, paint, and other foreign material by the use of sandblasting or waterblasting. Suitable traps shall be installed in sandblasting or waterblasting equipment to prevent oil from being deposited on the surface.

## SECTION 530

**3.1.2** Surfaces which have been cured by the use of curing compound shall not be coated with waterproof finish until at least 30 days have elapsed since curing compound application.

### **3.2 Brush and Flat Waterproofed Finish.**

**3.2.1** All work shall be performed by an experienced Contractor who is familiar with waterproofing work and with the materials specified herein.

**3.2.2** No application is to be made when atmospheric temperature is 45 °F (7 °C) or below, or if it is expected to drop below 45 °F (7 °C) within 24 hours after application. Do not apply to frozen or frost-filled surfaces. If the application is made during hot weather, cool the surface with clean water first.

**3.2.3** All materials shall be mixed according to the manufacturer's printed instructions and a copy of such instructions shall be maintained on the project.

**3.2.4** The cement base waterproof coatings shall be applied by the use of a masonry brush to a slightly dampened surface. The material shall be cured in accordance with the manufacturer's recommendations. Sufficient material must be applied to fill and seal all pores and voids to achieve a uniform appearance.

**3.2.5** The cement base, acrylic latex, coating shall be applied at the rate recommended by the manufacturer.

**3.2.6** The cement base, polymer-modified, coating shall be applied at the rate recommended by the manufacturer.

**3.2.7** Whenever construction or contraction joints appear in the existing or new concrete to be coated, the joints shall be tooled to allow bond breakage of the coating at the joint.

### **Method of Measurement**

**4.1** Waterproofing concrete surfaces will not be measured, but shall be the square yard (square meter) final pay quantity in accordance with 109.11 of coated surface within the limits shown on the plans.

### **Basis of Payment**

**5.1** Waterproofing concrete surfaces is a final pay quantity item and will be paid for at the Contract unit price per square yard (square meter) complete in place in accordance with 109.11.

#### **Pay item and unit:**

530.3	Waterproofing Concrete Surfaces (F)	Square Yard (Square Meter)
-------	-------------------------------------	----------------------------

## **SECTION 534 -- WATER REPELLENT**

### **Description**

**1.1** A water repellent of the type specified shall be applied to the concrete surfaces shown on the plan or as ordered. Surfaces to be treated shall normally consist of the following portions of all bridges:

concrete curbs, sidewalks (top, fascia, bottoms), and wingwalls including 1 ft (300 mm) below fill areas. Application shall be performed on surfaces on which no other coating is applied.

### Materials

**2.1** Boiled linseed oil mixture shall conform to AASHTO M 233 and shall be composed of 50 percent double boiled linseed oil and 50 percent petroleum spirits, by volume and shall be a product as included on the Qualified Products List.

**2.2** Water repellent (silane-siloxane) shall be a product as included on the Qualified Products List.

### Construction Requirements

**3.1 General.** All caulking, patch, and joint sealers shall be installed prior to application of the water repellent. Concrete surfaces shall have cured a minimum of 14 days and shall be dry prior to the application of water repellent. Minimum substrate and ambient application temperatures shall be as noted on the Qualified Products List for the product used except as allowed in 3.1.2 and 3.1.3. Do not apply when substrate surface temperature exceeds 29°C (85°).

**3.1.1** All surfaces specified for treatment, that require finishing, shall be protected from freezing and de-icing chemicals until coated with water repellent. All finished surfaces specified for treatment must be treated before winter shutdown.

**3.1.2** If the project schedule requires that surfaces be coated outside the product application temperatures listed in the Qualified Products List, those surfaces shall be recoated during the next construction season with the same product when the application temperature is within the listed temperature range and other conditions meet manufacturer's recommendations during the next construction season. Prior to reapplication of water repellent, the surface shall be thoroughly cleaned by water blasting and allowed to dry.

**3.1.3** If cold weather concreting practices as described in Section 520.3.7 are being followed, the 14-day provision of 3.1 is waived. The concrete shall be coated as soon as it is dry after the five-day period specified in Section 520.3.7 and it shall be protected from freezing until coated. Concrete that is treated with water repellent under these conditions shall be recoated as described in 3.1.2.

**3.2** Resin or wax based curing compounds shall not be used on new concrete where sealers are to be applied.

**3.3 Linseed oil.** Water repellent with linseed oil may be applied on horizontal surfaces by any approved means. If a sprayer is used, the nozzle shall be held within 18 in (500 mm) of the concrete or as directed. On vertical surfaces the mixture may be applied by spraying, brushing, or rolling and applications shall be started at the base and coated upward to the top.

**3.3.1** Two coats of linseed oil mixture shall be applied. The first shall be at a rate sufficient to obtain maximum penetration, taking care to prevent the material from discoloring curbs or other parts of the work. The second coat shall be applied as a seal coat, with attention given to the lighter appearing areas. The rate of application shall be approximately 0.025 gal/yd<sup>2</sup> (100 mL/m<sup>2</sup>) for the first coat and 0.015 gal/yd<sup>2</sup> (70 mL/m<sup>2</sup>) for the second coat, or an average of approximately 0.04 gal/yd<sup>2</sup> (170 mL/m<sup>2</sup>). The second application shall not be made until the concrete has regained its dry appearance and in any event not until at least 24 hours have passed.

**3.3.2** The linseed oil - petroleum spirits mixture is flammable and all due precautions shall be observed.

## SECTION 534

**3.4 Silane-Siloxane.** Water repellent (silane-siloxane) shall not exceed a rate of .01 gal/ft<sup>2</sup> or manufacturer's recommendation which ever is less, while maintaining the product temperature within the manufacturer's recommended range. Ambient application temperatures, except as allowed in sections 3.1.2 and 3.1.3, shall conform to the product application temperature listed on the Qualified Products List.

**3.4.1** A test application shall be performed on the surface to be treated, to insure compatibility, using the same equipment to be used on the project. After a minimum of three days, the Engineer shall test for waterproof effectiveness by applying water to the surface. If the water beads up and is not readily absorbed, the test is positive.

**3.4.2** The Contractor shall follow the manufacturer's instructions in the method of preparation of the concrete and application of the sealer.

### Method of measurement

**4.1** Water repellent (linseed oil) and water repellent (silane-siloxane), applied to surfaces within the limits shown in the plans or specified herein and at the rates required in sections 3.3.1 or 3.4 respectively, will be measured by the gallon (liter).

### Basis of Payment

**5.1** Water repellent of the type specified will be paid for at the Contract unit price per gallon (liter) , complete in place. The reapplication of water repellent as required in 3.1.2 and 3.1.3 will be done at the Contractor's expense unless the required reapplication was due to circumstances beyond the Contractor's control, as determined by the Engineer.

### Pay items and units:

534.1	Water Repellent (Linseed Oil)	Gallon (Liter)
534.3	Water Repellent (Silane-Siloxane)	Gallon (Liter)

## ***SECTION 536 -- EPOXY COATING FOR CONCRETE***

### Description

**1.1** This work shall consist of furnishing and placing on concrete surfaces as shown on the plans a flexible, minimum two-coat, epoxy coating system consisting of a mortar coat and one or more seal coats. The resulting color shall be approximately the shade of hardened concrete.

### Materials

**2.1** Epoxy coating shall be an epoxy compound and shall be furnished in two components for combining immediately prior to use in accordance with the stipulations in this specification. The epoxy coating system shall be a product as included on the Qualified Products List.

**2.1.1** The material for the mortar coat shall consist of 100 percent solids. The Component "A" shall be an epoxy resin containing a thixotropic agent. The Component "B" (Hardener) shall be chemically pure amido-amine or poly-amide with no other fillers, diluents or wettings, or volatile solvents. Sand shall be used in the mortar coat. The proportion of sand in the epoxy mortar shall be determined by the Bureau of Materials and Research. The two components of the epoxy system furnished under this specification shall be supplied in separate pre-proportioned containers. A unit of Component

“A” shall be supplied in a container with enough capacity to allow the mixing in it of the Component “B”, together with the sand for the mortar coat.

**2.1.2** The material for the seal coat shall consist of a pigmented, solvent-cut two-component epoxy polyamide. The color shall be concrete gray.

**2.1.3** Containers shall be identified as “Component A, Contains Epoxy Resin” and “Component B, Contains Hardener”. Labels shall show the component type, whether trowel grade or brush grade, mixing directions, and usable temperature range, all as defined by this specification. Each container shall be marked with the name of the manufacturer, the lot or batch number, the date of packaging, pigmentation, if any, and the quantity contained therein in pounds and gallons (kilograms and liters).

**2.1.4** At 70 °F (20 °C), the mortar grade shall have a pot life of at least 45 minutes and the brush grade shall have a pot life of at least 8 hours.

**2.1.5** The epoxy shall be formulated for application at a temperature of 40 °F (5 °C) and above.

**2.1.6 Storage.** The Components A and B should be stored in a cool place in warm weather and a warm place in cold weather.

**2.2** Sand for mortar coat shall be Ottawa silica sand, or an approved equivalent, which will closely approximate the color of concrete. The sand shall be so graded that 100 percent by weight will pass a No. 4 (4.75 mm) sieve, 20 to 30 percent will pass a No. 50 (0.300 mm) sieve and 0 to 5 percent will pass a No. 100 (0.150 mm) sieve.

**2.2.1** Sand shall be furnished on the project as a pre-dried product in moisture-proof containers.

### Construction Requirements

**3.1 Preparation and surfaces.** Acid etching will not be allowed. Surfaces of concrete shall not be “finished” but shall be sandblast cleaned before applying the first coat, not only to remove all film or laitance, but also to remove the surface of the concrete deep enough to eliminate any formation over voids. The object is to obtain a durable concrete surface. The area to be treated must be surface-dry, and all dust and sand residue from blast cleaning shall be removed. The temperature of the concrete shall be 40 °F (5 °C) or above. Concrete shall be cured a minimum of 14 days, before coating is applied.

**3.2 Mixing.** Mixing of the epoxy shall be done immediately prior to use and strictly in accordance with the manufacturer’s directions shown on the container. The epoxy resin and hardener shall be mixed the specified time using an approved propeller-type stirrer designed for the quantity to be mixed. For the mortar coat, after the 2 components have been thoroughly mixed, sand shall be added strictly in the proportion ordered, and mixing shall be continued until a homogeneous mixture has been obtained.

### 3.3 Applications.

**3.3.1 Mortar coat.** The epoxy and sand mixture shall be applied with a screed or trowel to completely fill all cavities or imperfections present in the concrete. Depending upon the particular brand used and the quality of the concrete surface, to cover 30 ft<sup>2</sup> (0.75 m<sup>2</sup>) of area with the trowel coat may require approximately 1 gal (1 L) of the mixture.

**3.3.2 Seal coat.** After the mortar coat has hardened, the seal coat shall be applied as soon as possible using a brush or roller in the manner recommended by the manufacturer and taking extreme care to fill all pinholes or other voids which may exist in the underlying coat. It is estimated that to cover approximately 200 ft<sup>2</sup> (5 m<sup>2</sup>) of surface will require 1 gal (1 L) of epoxy seal coat.

## SECTION 536

**3.3.3** In case adequate coverage has not been obtained, one or more additional coats may be ordered.

**3.4 Safety precautions.** Proper protective equipment shall be used and other actions shall be taken against the possibility of skin damage to humans and against the possibility of fire, since the material may be a dermatitis producer and a fire hazard.

### Method or Measurement

**4.1** Epoxy coating of the type specified will not be measured, but shall be the square foot (square meter) final pay quantity in accordance with 109.11 for the coated surface required within the limits shown on the plans.

### Basis of Payment

**5.1** Epoxy coating of the type specified is a final pay quantity item and will be paid for at the Contract unit price per square foot (square meter) complete in place in accordance with 109.11.

### Pay items and units:

536.11	Epoxy Coating for Concrete (F)	Square Foot (Square Meter)
536.3	High Build, High-Gloss White Epoxy Coating for Concrete (F)	Square Foot (Square Meter)

## SECTION 537 -- CONCRETE SEALER

### Description

**1.1** This work shall consist of furnishing and applying concrete sealer on all concrete surfaces deemed susceptible to staining by rust. Unless otherwise shown on the plans or ordered, these surfaces shall consist of the following portions of the bridges not coated with epoxy coating: abutment face walls, bridge seats, and all pier areas except those below ground or under water. This work shall also consist of the cleaning of rust stains from these surfaces and the reapplication of sealer on these surfaces.

### Materials

- 2.1** Concrete sealer shall be a sealer as included on the Qualified Products List.
- 2.2** Cleaner for rust stains shall be ferrous stain remover as included on the Qualified Products List.

### Construction Requirements

**3.1** After the concrete surfaces have attained a dry appearance, the sealer shall be applied by the use of a paint roller or brush, to obtain a uniform coating. The first coat shall be applied at a rate of approximately 100 ft<sup>2</sup>/gal (2.5 m<sup>2</sup>/L) and a second coat at the rate of approximately 300 ft<sup>2</sup>/gal (7.5 m<sup>2</sup>/L), the second coat being used to seal all pinholes not covered by the first coat. Applications shall start at the lower portions and continue upward.

**3.2** Prior to completion of the project and after the structural steel has obtained most of the initial oxidization, all rust stained areas of the concrete surface shall be cleaned.

**3.2.1** Cleaner shall be applied in the concentrated form directly to the concrete surfaces and allowed to remain 3 to 35 minutes. If stains still remain, a light brushing should be performed while the cleaner is still present. The concentrated material shall be reapplied and then rinsed with fresh water by means of a pressure hose. Care shall be taken to remove all cleaner from the surfaces. All safety precautions as recommended by the manufacturer shall be followed.

**3.3** An additional coat of sealer shall be applied to the areas where cleaner has been used, at the rate of approximately 300 ft<sup>2</sup>/gal (7.5 m<sup>2</sup>/L) to reseal the surfaces, using a low pressure sprayer (20 to 30 psi [140 to 200 kPa] pressure) fitted with neoprene hose, gaskets, and washers, a roller or a brush.

**3.4** All adjacent surfaces not being sealed, including pavement, shall be protected from spray or drips.

**Method of Measurement**

**4.1** Concrete sealer will not be measured, but shall be the square foot (square meter) final pay quantity in accordance with 109.11 for the coated surface required within the limits specified herein or shown on the plans.

**Basis of Payment**

**5.1** Concrete sealer is a final pay quantity item and will be paid for at the Contract unit price per square foot (square meter) complete in place in accordance with 109.11. Cleaner will be subsidiary.

**Pay item and unit:**

537.	Concrete Sealer (F)	Square Foot (Square Meter)
------	---------------------	----------------------------

**SECTION 538 -- BARRIER MEMBRANE**

**Description**

**1.1** This work shall consist of furnishing and applying an approved waterproof membrane system as shown on the plans or as ordered.

**Materials**

**2.1** Barrier membrane shall consist of adhesive primer, preformed waterproofing membrane sheet and mastic all as one system with all components being recommended by the manufacturer and as included on the Qualified Products List.

**2.2** Protection board shall be a product as included on the Qualified Products List.

**Construction Requirements**

**3.1 Preparation of the surface.** The surface of the deck shall have a smooth, fine-textured finish. All honeycombed areas and surface cavities shall be cleaned and filled with approved patching materials.

## SECTION 538

The entire deck shall be abrasive blasted to achieve an anchor profile which is clean, and free of laitance, oil and foreign materials. Prior to blasting, the surface shall be dry and free of sharp protrusions.

**3.1.1 Conditions before application.** The concrete deck shall be cured in accordance with the requirements of 520.3.10. The primer and membrane shall only be applied when the substrate surface has a moisture content of 6 percent or less, and when the temperature of the substrate exceeds the dew point. The Contractor shall supply a portable electronic surface moisture meter capable of measuring the moisture content of concrete surfaces in percent as included on the Qualified Products List to perform testing. The air temperature shall be at least 40 °F (5 °C) and rising.

**3.2 Application of adhesive primer.** Immediately prior to application of the primer, the deck shall be cleaned by brooms and compressed air. The concrete surface shall be inspected and approved by the Engineer and the Applicator prior to priming.

**3.2.1** The adhesive primer shall be thoroughly mixed before use and applied by roller only and allowed to cure in accordance with the manufacturer's recommendations.

**3.3 Application of membrane.** Membrane shall be installed in a shingled pattern so that water is permitted to drain to the low areas of the deck without accumulating against seams, and pressed or rolled into place to assure bond with the primed surface and elimination of air bubbles. Laps shall be staggered at the beginning and ends of rolls and shall overlap the previous roll and sealed in accordance with the manufacturer's recommendation.

**3.3.1** All expansion joints, areas around drains, all membrane junctions with curbs, end dams, protrusions, and all inside corners shall receive an extra 6 in (150 mm) wide strip of preformed membrane prior to normal coverage.

**3.3.2** Torn or damaged membrane shall be repaired in accordance with manufacturer's recommendations.

**3.3.3** Membraned surfaces to be backfilled against shall be protected from rupture by a protection board, including horizontal surfaces of box culverts and rigid frames.

**3.4** Seal along the curb and edges in accordance with the manufacturer's recommendation.

**3.5 Application of hot bituminous overlay.** The laydown temperature of pavement overlays used in connection with barrier membrane shall be within the tolerances prescribed by the manufacturer and available from the Bureau of Materials and Research. It should be noted that the laydown temperatures are extremely critical in order to preserve membrane integrity.

**3.5.1** See 401.3.5.12 for time restrictions concerning placement of pavement.

### Method of Measurement

**4.1** Barrier membrane of the type specified will not be measured, but shall be the square yard (square meter) final pay quantity in accordance with 109.11 for the waterproofed surfaces within the limits shown on the plans.

### Basis of Payment

**5.1** Barrier membrane of the type specified is a final pay quantity item and will be paid for at the contract unit price per square meter (square yard) complete in place in accordance with 109.11.

5.2 Protection board where required will be subsidiary.

**Pay items and units:**

538.1	Barrier Membrane (F)	Square Foot (Square Meter)
538.2	Barrier Membrane, Vertical Surfaces (F)	Square Foot (Square Meter)

**SECTION 541 -- WATERSTOPS**

**Description**

**1.1** This work shall consist of furnishing and placing waterstops in expansion, contraction, and construction joints as shown or ordered.

**1.2 Polyvinyl chloride types.** Following are the basic types of PVC waterstops to be required under this specification:

Type	Use	Description
NH #1	For construction joints through which the reinforcing steel extends, and no appreciable movements are expected.	3/16 in (5 mm) min. thick by 4 in (100 mm) min. wide, dumbbell or ribbed (split optional), no center bulb.
NH #2	For contraction joints (keyed) without reinforcing steel or with shear steel only, where slight contraction and deflection movements are expected.	3/16 in (5 mm) min. thick by 6 in (150 mm) min. wide, dumbbell or ribbed (split optional), 1/4 in (6 mm) min. I.D. by 1/2 in (13 mm) min. O.D. center bulb.
NH #3	For expansion joints (keyed) with 1/2 in (13 mm) of cork filler, where nominal expansion, contraction, and rotational movements are expected.	3/16 in (5 mm) min. thick by 6 in (150 mm) min. wide, dumbbell or ribbed (split optional), 1/4 in (6 mm) min. I.D. by 3/4 in (19 mm) min. O.D. center bulb.
NH #4	For expansion joints (not keyed) with 1/2 or 1 in (13 or 25 mm) of cork filler, where appreciable expansion, contraction, rotational, and/or shear movements are expected.	3/8 in (9.5 mm) min. thick by 9 in (225 mm) min. wide, dumbbell or ribbed (split optional), 3/4 in (19 mm) min. I.D. by 1-1/2 in (38 mm) min. O.D. center bulb.
NH #5	For lapping over the horizontal joint between the top of the abutment backwall and the bottom of the bridge deck haunch beam at the fixed end.	2-1/2 in (63 mm) min. by 6 in (150 mm) min. "L" shaped, by 1/4 in (6 mm) min. thick, ribbed on the 2-1/2 in (63 mm) leg.

**1.2.1** The use of waterstops with larger dimensions than those shown above will be permitted.

## SECTION 541

### Materials

2.1 PVC waterstops shall conform to the requirements of the United States Army Corps of Engineers Specification CRD-C 572 and shall be a product as included on the Qualified Products List.

### Construction Requirements

3.1 The waterstops shall be installed and any necessary splicing made strictly in accordance with the manufacturer's recommended procedure, the plans, or as directed.

3.1.1 When present, the PVC center bulb shall be centered in the concrete joint.

### Method of Measurement

4.1 Waterstops will not be measured, but shall be the linear foot (linear meter ) final pay quantity in accordance with 109.11 for material required as shown on the plans.

### Basis of Payment

5.1 Waterstops are final pay quantity items and will be paid for at the Contract unit price per linear foot (linear meter) complete in place in accordance with 109.11.

### Pay items and units:

541.1	PVC Waterstops, NH Type 1(F)	Linear Foot (Linear Meter)
541.2	PVC Waterstops, NH Type 2(F)	Linear Foot (Linear Meter)
541.3	PVC Waterstops, NH Type 3(F)	Linear Foot (Linear Meter)
541.4	PVC Waterstops, NH Type 4(F)	Linear Foot (Linear Meter)
541.5	PVC Waterstops, NH Type 5(F)	Linear Foot (Linear Meter)

## SECTION 544 -- REINFORCING STEEL

### Description

1.1 This work shall consist of furnishing and placing reinforcing steel as shown on the plans or ordered.

### Materials

2.1 Bar reinforcement shall be Grade 420 (Grade 60) or as shown on the plans.

2.1.1 Billet-steel bars shall conform to AASHTO M 31 (AASHTO M 31M).

2.1.2 Rail-steel bars shall conform to AASHTO M 42/M 42M.

2.2 Welded steel wire fabric shall conform to AASHTO M 55/M 55M.

2.3 Bundled reinforcement shall be used only as shown on the plans or with written permission.

**2.4 Foreign steel.** The use of foreign steel will be permitted only after approval by the Engineer upon suitable certification from a recognized domestic laboratory.

### **2.5 Epoxy Coated Reinforcing Steel**

**2.5.1** Epoxy coated reinforcing steel shall meet the requirements of AASHTO M 284/M 284M and AASHTO M 317/M 317M.

**2.5.2** A written certification by the manufacturer of the powdered epoxy resin attesting to the AASHTO M 284/M 284M requirements shall be furnished for each lot to the Administrator, Bureau of Materials and Research by the Contractor.

**2.5.2.1** The certificate shall also contain the insignia or other similar statement that the plant is a currently approved fusion-bonded epoxy coating applicator, as defined by the Concrete Reinforcing Steel Institute (CRSI) Plant Certification Program.

**2.5.3** The epoxy coating applied to the bars shall be uniform and smooth and shall provide a film thickness of  $10 \pm 2$  mils ( $0.25 \pm 0.05$  mm) after curing.

**2.5.4** All chair and bar supports used for the installation of epoxy coated reinforcing bars shall be epoxy-coated, vinyl-coated, or plastic-coated wire bar supports, or coated with a material approved in writing by the Administrator, Bureau of Material and Research. Plastic slab bolster bar supports may be utilized for installing epoxy coated reinforcing bars. Continuous plastic bar supports between the top and bottom mats are not acceptable.

### **Construction Requirements**

**3.1 Bar list.** The Department's bar list and bending schedule is made for the purpose of arriving at an estimate of quantities. The Contractor shall verify the quantity, size, and shape of the bar reinforcement against the structure drawings and make the necessary corrections, if any, before ordering. Errors in the bar list and bending schedule shall not be cause for adjustment of Contract unit price.

**3.2 Surface condition of reinforcement.** The reinforcing steel, at the time concrete is placed, shall be free of dirt, paint, oil, or other organic materials that may adversely affect or reduce bond. Metal reinforcement coated with firmly bonded rust, mill scale, or a combination of both shall be considered satisfactory provided the minimum dimensions and weight of a hand wire-brushed test specimen are not less than the applicable specification requirement. Rust or mill scale which is difficult to remove by vigorous scrubbing with a wire brush shall be considered firmly bonded to the steel.

**3.3 Bending.** Unless otherwise permitted, all reinforcing bars shall be bent cold. Bars partially embedded in concrete shall not be field bent except as shown on the plans or permitted. Only competent people shall be employed for cutting and bending, and proper appliances shall be provided for such work. Should the Engineer approve the application of heat for field bending reinforcing bars, precautions shall be taken to assure that the physical properties of the steel will not be materially altered.

**3.4 Placing and fastening.** Reinforcing steel shall be free from mortar and other objectionable substances, shall be accurately placed as shown or ordered, and shall be securely blocked and tied unless otherwise permitted. Blocking shall be by rust-resistant chairs unless otherwise permitted. Tack welding will be prohibited except upon special written approval of the Engineer. This provision also prohibits welding form ties to the reinforcement.

**3.4.1** Reinforcing steel for bridge decks shall be epoxy coated unless otherwise shown on the plans. Bridge deck reinforcing steel shall be placed on epoxy or plastic-coated steel wire supports in accordance

## SECTION 544

with 2.5.4 and the Concrete Reinforcing Steel Institute Manual of Standard Practice. The bottom reinforcing shall be supported on type SB supports with the end of the supporting wire lapped to lock the last legs of adjoining units. The top reinforcing shall be supported by type CHCU bar supports placed between the top and bottom mats. The ends of the top supporting wire shall be lapped. The supports shall be sized and spaced to allow for the minimum cover of the reinforcing bars called for on the plans. At least 50 percent of the junctions of the reinforcing mat shall be tied.

**3.4.2** If plain reinforcing steel for the bridge deck is called for on the plans, then plastic protected or stainless steel protected supports may be used to support the bottom reinforcing mat and bright basic bar supports may be used between the top and bottom mats.

**3.4.3** Concrete shall not be placed in any member until the placement of the reinforcing steel has been inspected and approved.

**3.5 Splices.** Reinforcing steel shall be furnished in the full lengths indicated on the plans unless otherwise permitted. Splices shall be made as shown on the plans or as permitted. No splices will be permitted at points where the section does not provide a minimum distance of 2 in (50 mm) between the splices and the nearest adjacent bar or surface of the concrete. The bars shall be rigidly clamped or wired at all splices. Sheets of metal mesh shall overlap each other sufficiently to maintain uniform strength and shall be securely fastened at the ends and edges.

**3.5.1** Splices made with mechanical connectors shall be as detailed on the plans or as permitted and shall develop at least 125% of the specified yield strength of the reinforcing bar being spliced. The minimum concrete cover over the reinforcing steel as shown on the plans shall be maintained at the mechanical splice.

**3.5.1.1** The Contractor shall submit two mechanical connectors connecting two 12 in (300 mm) sections of reinforcing steel of each size per lot per project. Connector and reinforcing steel assemblies will be tested by the Department.

**3.6** Handling, fabrication, and repair of epoxy coated reinforcing steel shall be in conformance with the applicable sections of AASHTO M 284/M 284M and AASHTO M 317/M 317M.

**3.6.1** If stored outdoors, the bars shall be covered for protection against the elements and in such a manner that condensation does not form on the bars. The bars shall not be exposed to sunlight for periods exceeding three months.

**3.7** Epoxy coated reinforcing steel which requires cutting shall be sawn. No flame-cutting will be allowed. Cut ends of bars shall be recoated with epoxy as soon as possible and before visible oxidation occurs.

### Method of Measurement

**4.1** Reinforcing steel of the type specified, except reinforcing steel (roadway), will not be measured, but shall be the pound (kilogram) final pay quantity in accordance with 109.11 for reinforcing steel required as shown on the plans. Reinforcing steel (roadway) will be measured by the pound (kilogram) of reinforcing steel placed as shown on the plans or ordered. The theoretical weight(mass ) of reinforcing steel will be computed based on the following table.

**Table 1E - Reinforcing Steel Weight (English)**

Size Bar #	3	4	5	6	7	8	9	10	11	14	18
Lb. per Linear Foot	0.376	0.668	1.043	1.502	2.044	2.670	3.400	4.303	5.313	7.65	13.60

**Table 1 - Reinforcing Steel Mass (Metric)**

Size Bar #	10	13	16	19	22	25	29	32	36	43	57
Kilograms per Linear Meter	0.560	0.994	1.552	2.235	3.042	3.973	5.060	6.404	7.907	11.38	20.24

### Basis of Payment

**5.1** Reinforcing steel of the type specified, except reinforcing steel (roadway), are final pay quantity items and will be paid for at the Contract unit price per pound (kilogram) complete in place in accordance with 109.11. The accepted quantity of reinforcing steel (roadway) will be paid for at the Contract unit price per pound (kilogram) complete in place. No allowance will be made for clips, wire or other material used for fastening reinforcement in place, and no allowance will be made for additional splices or permitted substitutions.

**5.1.1** For mechanical splice bars no allowance will be made in excess of the length detailed on the plans for the additional weight required to manufacture and provide a mechanical splice to the plan specifications.

**5.2 Structural steel.** In reinforced concrete structures that have no structural steel bid items, structural steel will be paid for at the unit price per pound (kilogram) bid for reinforcing steel, unless otherwise indicated in the Contract.

#### Pay items and units:

544	Reinforcing Steel (F)	Pound (Kilogram)
544.1	Reinforcing Steel (Roadway)	Pound (Kilogram)
544.11	Reinforcing Steel-Mechanical Connectors (F)	Pound (Kilogram)
544.2	Reinforcing Steel-Epoxy Coated (F)	Pound (Kilogram)
544.21	Reinforcing Steel-Epoxy Coated Mechanical Connectors (F)	Pound (Kilogram)

## SECTION 547

### SECTION 547 -- SHEAR CONNECTORS

#### Description

**1.1** This work shall consist of furnishing and welding steel shear connectors to structural steel for use in composite beam construction as shown on the plans. All requirements of this section apply to studs except for structural shapes, as noted.

#### Materials

##### 2.1 General Requirements for Studs.

**2.1.1** Studs shall be of suitable design for arc welding to steel members with the use of automatically timed stud welding equipment. The dimensions for standard headed type round studs shall conform to Table 1.

**Table 1E - Dimensions of Standard Type Shear Connectors (English)**

Standard dimensions, inches

Shank diameter	Head diameter	Minimum head height
3/4	1-1/4	3/8
7/8	1-3/8	3/8

**Table 1 - Dimensions of Standard Type Shear Connectors (Metric)**

Standard dimensions, mm

Shank diameter	Head diameter	Minimum head height
19	32	10
22	35	10

**2.1.2** An arc shield (ferrule) of heat resistant ceramic or other suitable material shall be furnished with each stud. The material shall not be detrimental to the welds or cause excessive slag and shall have sufficient strength so as not to crumble or break due to thermal or structural shock before the weld is completed.

**2.1.3** A suitable deoxidizing and arc stabilizing flux for welding shall be furnished with each stud, either attached to the end of the stud or combined with the arc shield, for automatic application in the welding operation.

**2.1.4** Only studs with qualified stud bases shall be used. (The stud base is the stud tip at the welding end, including flux, and 1/8 in (3 mm) of the body of the stud adjacent to the tip). A stud base, to be qualified, shall have passed the test prescribed in Annex VI, AASHTO/AWS D1.5. The arc shield used in production shall be the same as used in qualification tests or as recommended by the

manufacturer. Qualification of stud bases in accordance with Annex VI, AASHTO/AWS D1.5, shall be at the manufacturer's expense.

**2.1.5** Finish shall be produced by heading, rolling, or machining. Finished studs shall be of uniform quality and condition, free of injurious laps, fins, seams, cracks, twists, bends, or other injurious discontinuities. Radial cracks or bursts in the head of a stud shall not be the cause for rejection, provided that the cracks or bursts do not extend more than half the distance from the head periphery to the shank, as determined by visual inspection.<sup>1</sup>

(Footnote 1. Heads of shear connectors or anchor studs are subject to cracks or bursts, which are names for the same thing. Cracks or bursts designate an abrupt interruption of the periphery of the stud head by radial separation of the metal. Such interruptions do not adversely affect the structural strength, corrosion resistance, or other functional requirements of headed studs.)

**2.1.6** Only bases qualified under Annex VI, AASHTO/AWS D1.5, shall be used. When requested by the Engineer, the Contractor shall provide the following information:

- (a) A description of the stud and arc shield.
- (b) Certification from the manufacturer that the stud base is qualified as specified in 2.1.4.
- (c) Qualification test data.

## 2.2 Mechanical Requirements for Studs.

**2.2.1** Studs shall be made from cold drawn bar stock conforming to the requirements of AASHTO M 169 (ASTM A 108), Grades 1010 through 1020, inclusive, either semi-killed or killed deoxidation.

**2.2.2** Studs shall conform to mechanical property requirements of Table 2. At the manufacturer's option, mechanical properties of studs shall be determined by testing either: (1) the steel after cold finishing, or (2) the full diameter finished studs.

**Table 2 - Mechanical Property Requirements for Studs\***

Tensile strength	60,000 psi (415 Mpa) min.
Yield strength (0.2% offset)	50,000 psi (350 Mpa) min.
Elongation (% in 50,000 psi (50 mm))	20% min.
Reduction of area	50% min.

\* These are standard headed type studs in 3/4 and 7/8 in (19 and 22 mm) diameter that are used as an essential component in composite beam design and construction.

**2.2.3** Mechanical properties shall be determined in accordance with the applicable sections of ASTM A 370. A typical test fixture shall be used similar to that shown in Figure 7.2, AASHTO/AWS D1.5.

**2.2.4** Upon request by the Engineer, the Contractor shall furnish:

- (1) The stud manufacturer's certification that the studs, as delivered, conform to the applicable requirements of 2.1 and 2.2.
- (2) Certified copies of the stud manufacturer's test reports covering the last completed set of in-plant quality control mechanical tests, required by 2.2 for each stock size delivered. The quality control test shall have been made within the six-month period before delivery of the studs.

## SECTION 547

**2.2.5** When quality control tests are not available, the Contractor shall furnish mechanical test reports conforming to the requirements of 2.2. The mechanical tests shall be on finished studs provided by the manufacturer of the studs. The number of tests to be performed shall be specified by the Engineer.

**2.2.6** The Engineer may select studs of each type and size used under the Contract as necessary for checking the requirements of 2.1 and 2.2. Furnishing these studs shall be at the Contractor's expense. Testing shall be at the Department's expense.

**2.3** Structural shapes shall conform to AASHTO M 183/M 183M (ASTM A 36/A 36M).

### Construction Requirements

#### 3.1 Workmanship.

**3.1.1** Stud shear connectors shall be welded to structural steel in the field, unless directed otherwise. If studs are shop welded, suitable staging shall be installed at the erected structure to permit the Engineer to safely take the necessary grade elevations.

**3.1.2** At the time of welding, the studs shall be free from rust, rust pits, scale, oil, moisture, or other deleterious matter that would adversely affect the welding operation.

**3.1.3** The stud base shall not be painted, galvanized, or cadmium-plated prior to welding.

**3.1.4** The areas to which the studs are to be welded shall be free of scale, rust, moisture, paint, or other injurious material to the extent necessary to obtain satisfactory welds. These areas shall be cleaned by grinding to bare metal.

**3.1.5** The arc shields or ferrules shall be kept dry. Any arc shields which show signs of surface moisture from dew or rain shall be oven dried at 250 °F (120 °C) for two hours before use.

**3.1.6** Longitudinal and lateral spacings of stud shear connectors with respect to each other and to edges of beam or girder flanges shall not vary more than 1/2 in (13 mm) from the location shown on the plans, except that a variation of 1 in (25 mm) will be permitted, where required, to avoid obstruction with other attachments on the beam or where a new stud is being welded to replace a defective one. The minimum distance from the edge of a stud base to the edge of a flange shall be 1 in (25 mm), but preferably not less than 1-1/2 in (38 mm). The minimum spacing between adjacent studs shall be 3 in (75 mm) center to center for 3/4 in (19 mm) studs and 3-1/2 in (89 mm) for 7/8 in (22 mm) studs.

**3.1.7** After welding, arc shields shall be broken free from studs.

**3.1.8** The studs, after welding, shall be free of any discontinuities or substances that would interfere with their intended function. However, nonfusion on the legs of the flash and small shrink fissures are acceptable.<sup>2,3</sup>

(Footnote 2. The fillet weld profiles shown in Figure 3.3 AASHTO/AWS D1.5 do not apply to the flash of automatically timed stud welds.)

(Footnote 3. The expelled metal around the base of the stud is designated as flash in accordance with the definition of flash in Annex V of AASHTO/AWS D1.5. It is not a fillet weld such as those formed by conventional arc welding. The expelled metal, which is excess to the weld required for strength, is not detrimental but, on the contrary, is essential to provide a good weld. The containment of this excess molten metal around a welded stud by the ferrule (arc shield) assists in securing sound fusion of the entire cross section of the stud base. The stud weld flash may have nonfusion in its vertical leg and overlap on

its horizontal leg; and it may contain occasional small shrink fissures or other discontinuities that usually form at the top of the weld flash with essentially radial or longitudinal orientation, or both, to the axis of the stud. Such nonfusion on the vertical leg of the flash and small shrink fissures are acceptable.)

### 3.2 Technique.

**3.2.1** Studs shall be welded with automatically timed stud welding equipment connected to a suitable source of direct current straight polarity power. Welding voltage, current, time, and gun settings for lift and plunge should be set at optimum settings, based on past practice, recommendations of stud and equipment manufacturer, or both. AWS C5.4, Recommended Practices for Stud Welding, should also be used for technique guidance.

**3.2.2** If two or more stud welding guns are to be operated from the same power source, they shall be interlocked so that only one gun can operate at a time, and so that the power source has fully recovered from making one weld before another weld is started.

**3.2.3** While in operation, the welding gun shall be held in position without movement until the weld metal has solidified.

**3.2.4** Stud welding shall not be done when the base metal temperature is below 32°F (0°C) or when the surface is wet or exposed to falling rain or snow.

**3.2.5 Fillet weld option.** At the option of the Contractor, studs may be fillet welded by the shielded metal arc process, provided the following requirements are met:

**3.2.5.1** Welding is performed by a qualified welder, as per 550.3.16.

**3.2.5.2** The minimum fillet size to be used shall be 5/16 in (8 mm) for 3/4 and 7/8 in (19 and 22 mm) diameter studs.

**3.2.5.3** Welding shall be done with low hydrogen electrodes (E7018), 5/32 or 3/16 in (4 or 5 mm) in diameter.

**3.2.5.4** The stud base shall be prepared so that the base of the stud fits against the base metal.

**3.2.5.5** All rust and mill scale at the location of the stud shall be removed from the base metal by grinding. The end of the stud shall also be clean.

**3.2.5.6** The base metal to which studs are welded shall be preheated to 150 °F (65 °C) minimum.

**3.2.5.7** Fillet welded studs shall be visually inspected as per AASHTO/AWS D1.5, 6.6.2.

**3.3 Stud application qualification requirements.** Studs which are shop or field applied in the flat (down-hand) position to a planar and horizontal surface are deemed prequalified by virtue of the manufacturer's stud base qualification tests (Annex VI, AASHTO/AWS D1.5), and no further application testing is required. The limit of flat position is defined as 0-15 degree slope on the surface to which the stud is applied.

## SECTION 547

### 3.4 Stud Production Control.

#### 3.4.1 Pre-Production Testing.

**3.4.1.1** Before production welding with a particular set-up<sup>4</sup> and with a given size and type of stud, and at the beginning of each day's or shift's production, testing shall be performed on the first two studs that are welded. The stud technique may be developed on a piece of material similar to the production member in thickness and properties. If actual production thickness is not available, the thickness may vary plus or minus 25%. All test studs shall be welded in the same general position as required on the production member (flat).

(Footnote 4. Set-up includes stud gun, power source, stud diameter, gun lift and plunge, total welding lead length, or changes greater than  $\pm 5\%$  in current (amperage) and time.)

**3.4.1.2** Instead of being welded to separate material, the test studs may be welded on the production member, except when separate plates are required by 3.4.1.5.

**3.4.1.3** The test studs shall be visually examined. They shall exhibit full 360 degree flash.

**3.4.1.4** In addition to visual examination, the test shall consist of bending the studs, after they are allowed to cool, to an angle of approximately 30 degrees from their original axes by either striking the studs on the head with a hammer or placing a pipe or other suitable hollow device over the stud and manually or mechanically bending the stud. At temperatures below 50 °F (10 °C), bending shall preferably be done by continuous slow application of load.

**3.4.1.5** If on visual examination the test studs do not exhibit 360 degree flash, or if on testing failure occurs in the weld zone of either stud, the procedure shall be corrected, and two more studs shall be welded to separate material or on the production member and tested in accordance with the provisions of 3.4.1.3 and 3.4.1.4. If either of the second two studs fails, additional welding shall be continued on separate plates until two consecutive studs are tested and found to be satisfactory before any more production studs are welded to the member.

**3.4.1.6 Production welding.** Once production welding has begun, any changes made to the welding set-up as determined in 3.4.1 shall require that the testing in 3.4.1.3 and 3.4.1.4 be performed prior to resuming production welding.

**3.4.1.7** In production, studs on which a full 360 degree flash is not obtained may, at the option of the Contractor, be repaired by adding the minimum fillet weld as required by 3.2.5 in place of the missing flash. The repair weld shall extend at least 3/8 in (10 mm) beyond each end of the discontinuity being repaired.

**3.4.2 Operator qualification.** The pre-production test required by 3.4.1, if successful, shall also serve to qualify the stud welding operator. Before any production studs are welded by an operator not involved in the pre-production set-up of 3.4.1, the operator shall have the first two studs welded by him tested in accordance with the provisions of 3.4.1.3 and 3.4.1.4. When the two welded studs have been tested and found satisfactory, the operator may then weld production studs.

#### 3.4.3 Repairs.

**3.4.3.1** If an unacceptable stud has been removed from a component subjected to tensile stresses, the area from which the stud was removed shall be ground smooth and flush. Where in such areas the base metal has been pulled out in the course of stud removal, shielded metal arc welding with low hydrogen electrodes in accordance with the requirements of 3.2.5 shall be used to fill the pockets and the weld surface shall be flush.

**3.4.3.2** In compression areas of members, if stud failures are confined to shanks or fusion zones of studs, a new stud may be welded adjacent to each unacceptable area in lieu of repair and replacement on the existing weld area (See 3.1.6). If base metal is pulled out during stud removal, the repair provisions shall be the same as for tension areas except that when the depth of discontinuity is the lesser of 1/8 in (3 mm) or 7% of the base metal thickness the discontinuity may be blended smoothly by grinding in lieu of filling with weld metal. Where a replacement stud is to be provided, the base metal repair shall be made prior to welding the replacement stud. Replacement studs shall be tested by bending to an angle of approximately 15 degrees from their original axes. The areas of components exposed to view in completed structures shall be made smooth and flush where a stud has been removed.

**3.5 Fabrication and Verification Inspection Requirements for Studs.**

**3.5.1** If a visual inspection reveals any stud that does not show a full 360 degree flash or any stud that has been repaired by welding, such stud shall be bent to an angle of approximately 15 degrees from its original axis. The method of bending shall be in accordance with 3.4.1.4. The direction of bending for studs with less than a 360 degree flash shall be opposite to the missing portion of the flash.

**3.5.2** The Engineer shall select a reasonable number of studs to be subjected to the tests specified in 3.5.1.

**3.5.3** The bent stud shear connectors and other studs to be embedded in concrete that show no sign of failure shall be acceptable for use and left in the bent position. All bending and straightening when required shall be done without heating, before completion of the production stud welding operation, except as otherwise provided in the Contract.

**3.5.4** If, in the judgment of the Engineer, studs welded during the progress of the work are not in accordance with the provisions of this specification, as indicated by inspection and testing, corrective action shall be required of the Contractor. At his own expense, the Contractor shall make the set-up changes necessary to insure that studs subsequently welded will meet specification requirements.

**3.5.5** At the option and the expense of the Department, the Contractor may be required, at any time, to submit studs of the types used under the contract for a qualification check in accordance with the procedures of Annex VI, AASHTO/AWS D1.5.

**3.6 Welding Structural Shapes.**

**3.6.1** Structural shapes shall be fastened to the girders by shop or field welding, as shown on the plans.

**3.6.2** Welding shall be performed in accordance with the requirements of 3.2.5.

**Method of Measurement**

**4.1** Shear connectors will not be measured, but shall be the each final pay quantities in accordance with 109.11 for connectors required as shown on the plans.

**Basis of Payment**

**5.1** Shear connectors are a final pay quantity item and will be paid for at the Contract unit price per each complete in place in accordance with 109.11.

**Pay item and unit:**

547.	Shear Connectors (F)	Each
------	----------------------	------

## SECTION 548

### *SECTION 548 -- ELASTOMERIC BEARINGS*

#### **Description**

**1.1** This work shall consist of furnishing and placing elastomeric bearing pads for structural members. The pads shall be fabricated in conformity with the dimensions shown on the plans.

**1.2** This work shall consist of furnishing and placing elastomeric bearing assemblies for structural members. Assemblies shall include elastomeric bearing pads, masonry and sole plates, connection bolts, anchor bolts, nuts and washers, shim plates and fabric bearing pads. The assemblies shall be fabricated in conformity with the dimensions shown on the plans.

#### **Materials**

**2.1** Elastomeric bearing pads shall be furnished according to the Plans and as specified herein.

**2.1.1** Epoxy adhesive for bearing pads shall be a product as included on the Qualified Products List.

**2.2** Elastomeric compound shall be 100 percent virgin natural rubber meeting or exceeding the requirements of AASHTO Standard Specifications for Highway Bridges, Division II, Section 18, Table 18.4.5.1-1B.

**2.3** Internal steel plates shall conform to AASHTO M 270/M 270M (ASTM A709/A 709M), Grade 36 or 50 (or ASTM A36, A572)

**2.4** External load bearing plates shall conform to AASHTO M 270/M 270M (ASTM A709/A 709M), Grade 50W (345W).

**2.5** Preformed fabric bearing pads for external bearing plates shall conform to 550.2.6, Type 1.

**2.6** Anchor bolts shall conform to 550.2.5.

**2.7** The surface finish of bearing surfaces shall conform to AASHTO Standard Specifications for Highway Bridges, Division II, Section 11.4.6.

#### **2.8 Quality Assurance.**

**2.8.1** The Contractor shall furnish certified test results indicating compliance with each physical and chemical property specified.

#### **Construction Requirements**

**3.1** The fabrication, testing and installation shall be performed in accordance with the requirements of the Plans, AASHTO Standard Specifications for Highway Bridges, Division I, Section 14, and Division II, Section 18.

**3.2** The Contractor shall submit all shop fabrication drawings for approval in accordance with 105.02.

**3.2.1** Fabrication shall not begin until written approval of the submitted shop fabrication drawings has been received from the Department.

**3.3** The elastomeric bearing pads and assemblies shall be set on a carefully prepared surface as required by the applicable provisions of 550.3.15.5.

**3.4** The anchor bolts shall be installed as required by the applicable provisions of 550.3.15.4.

**3.5 Elastomeric bearings.** Following the manufacture of these bearings and verification of the internal steel laminates, the pin groove openings shall be coated with an approved asphaltic sealer and the space filled with silicone caulking.

#### Method of Measurement

**4.1** Elastomeric bearing pads or elastomeric bearing assemblies will not be measured, but shall be the Each final pay quantities in accordance with 109.11 for bearings required as shown on the plans. When more than one structure is included in the Contract, separate item numbers will be used for each separate and complete structure.

#### Basis of Payment

**5.1** Elastomeric bearing pads or elastomeric bearing assemblies are final pay quantity items and will be paid for at the Contract unit price per each complete in place in accordance with 109.11.

#### Pay items and units:

548.1X	Elastomeric Bearing Pads (F)	Each
548.2X	Elastomeric Bearing Assemblies (F)	Each

### SECTION 550 -- STRUCTURAL STEEL

DESCRIPTION.....	316
MATERIALS.....	316
2.1    General.....	316
2.2    Structural steel.....	316
2.3    Paint.....	317
2.4    High Strength Bolts.....	317
2.5    Anchor bolts.....	326
2.6    Preformed Fabric Bearing Pads.....	327
2.7    Stainless steel plate.....	328
2.8    Steel tubing.....	328
2.9    Galvanizing.....	328
2.10   PTFE surfaces for bearings.....	328
CONSTRUCTION REQUIREMENTS.....	328
3.1    General.....	328
3.2    Fabricator qualification.....	329
3.3    Shop Fabrication Drawings.....	329
3.4    Material Identification.....	330
3.5    Preparation of Base Metals.....	331
3.6    Shop Welding.....	332

## SECTION 550

3.7	Shop Inspection. ....	336
3.8	Nondestructive Testing of Welds. ....	338
3.9	Assembly of Shop Welded Connections. ....	339
3.10	Heat Curving, Cambering, and Straightening. ....	340
3.11	Connections Using High Strength Bolts. ....	341
3.12	Surface Preparation. ....	352
3.13	Shop Painting. ....	354
3.14	Handling, Storing, and Shipping Material. ....	354
3.15	Erection of Structural Steel. ....	356
3.16	Field Welding. ....	359
3.17	Field Painting. ....	360
3.18	Field Cleaning of Weathering Steel. ....	363
3.19	Removal of Rust and Stains from Concrete. ....	363
3.20	Fracture Control Plan. ....	363
	METHOD OF MEASUREMENT .....	364
	BASIS OF PAYMENT .....	364

### Description

**1.1 General.** This work shall consist of furnishing, fabricating, painting if required, transporting, and erecting all structural steel, bridge shoes, and other materials as shown on the plans.

**1.1.1** References to sections of AASHTO “Standard Specifications for Highway Bridges” Division II (current edition and interim specifications) are identified by the abbreviation AASHTO followed by the section number (e.g. AASHTO 11.3.1.7).

### Materials

**2.1 General.** Materials for steel structures shall be as specified in the current edition and interim specifications of the AASHTO “Standard Specifications for Highway Bridges”, unless otherwise specified herein.

**2.1.1** Materials shall conform to the AASHTO “Standard Specifications for Transportation Materials and Methods of Sampling and Testing”, in accordance with current editions and interim specifications, and as modified herein.

**2.2 Structural steel** Steel shall be furnished according to the following specifications, or as otherwise specified on the plans.

#### 2.2.1 General.

**2.2.1.1** Structural steel shall meet the General Requirements for Rolled Steel Plates, Shapes, Sheet Piling and Bars for Structural Use, AASHTO M 160/M 160M (ASTM A 6/A 6M).

**2.2.1.2** Unless otherwise specified, structural carbon steel shall be furnished for all structural steel. Structural carbon steel shall conform to AASHTO M 270/M 270M (ASTM A 709/A 709M), Grade 36.

**2.2.2** High-strength low-alloy (HSLA) structural steel shall conform to AASHTO M 270/M 270M (ASTM A 709/A 709M) Grade 50 (345) or Grade 50W (345W) (weathering), as shown on the plans.

**2.2.3 Charpy V-notch impact requirements.** All structural steel used in main load-carrying member components subject to tensile stress shall conform to the requirements for Zone 2 of AASHTO M 270/M 270M for the longitudinal Charpy V-notch impact tests.

**2.2.3.1** These impact requirements are mandatory for members including but not necessarily limited to rolled beams, welded cover plates, webs and tension flanges of built-up girders, flange and web splice plates, longitudinal stiffener plates, cross frames and their connection plates on horizontally curved girders, and other members as shown on the plans.

**2.3 Paint.** Paint shall conform to 708.

## **2.4 High Strength Bolts.**

### **2.4.1 Blank.**

### **2.4.2 Specifications.**

**2.4.2.1 Bolts.** High strength bolts for structural steel joints including suitable nuts and plain hardened washers shall meet the requirements of AASHTO M 164, ASTM A 325 (AASHTO M 164M, ASTM A 325M) as amended and modified herein. High strength bolts, nuts, and washers used with weathering steel shall be Type 3.

**2.4.2.1.1** When high strength galvanized bolts are specified, they shall conform to AASHTO M 298 (ASTM B 695) Class 50 for mechanically-deposited galvanizing. Use galvanized fasteners where structural steel is painted.

**2.4.2.1.2** The use of AASHTO M 253, ASTM A 490 (AASHTO M 253M, ASTM A 490M) bolts will not be permitted without authorization by the Administrator, Bureau of Bridge Design.

**2.4.2.2 Nuts.** Nuts shall conform to AASHTO M 291, ASTM A 563 (AASHTO M 291M, ASTM A 563M). AASHTO M 292, ASTM A 194 (AASHTO M292M, ASTM A 194M) is considered a suitable alternative.

**2.4.2.3 Washers.** All washers shall be hardened steel and shall conform to AASHTO M 293, ASTM F 436 (ASTM F 436M) and these specifications.

**2.4.2.4 Direct Tension Indicators (DTI).** All DTI's shall conform to the requirements of ASTM F 959 Type 325 (ASTM F 959M), except that DTI's shall not exceed Rockwell hardness C35. The DTI supplier shall certify that testing has been performed on equipment required by ASTM F 959 (ASTM F 959M).

**2.4.2.4.1** DTI's shall be furnished "galvanized" (i.e. mechanically zinc coated) unless noted otherwise. For use with weathering steel, DTI's shall be furnished as weathering steel or "painted" (i.e. mechanically galvanized and epoxy coated or baked epoxy).

### **2.4.3 Manufacturing.**

**2.4.3.1 Dimensions.** Bolt and nut dimensions shall conform to the dimensions given in Table 1E (Table 1M) (see Fig. 1) and shall conform to the requirements for Heavy Hexagon Structural Bolts and for Heavy Semi-Finished Hexagon Nuts given in the following specifications:

**SECTION 550**

**ENGLISH**

Bolts Heavy Hex Structural Bolts ANSI/ASME B18.2.6  
 Nuts Heavy Hex Nuts ANSI/ASME B18.2.2

**METRIC**

Bolts Metric Heavy Hex Structural Bolts ANSI B18.2.3.7M  
 Nuts Metric Heavy Hex Nuts ANSI B18.2.4.6M

**Table 1E - Bolt and Nut Dimensions (English)**

Nominal Bolt Size D	Heavy Hex Structural Bolts inches			Heavy Hex Nuts inches	
	Width Across Flats F	Height H	Thread Length	Width Across Flats W	Height H
1/2	7/8	5/16	1	7/8	31/64
5/8	1-1/16	25/64	1-1/4	1-1/16	39/64
3/4	1-1/4	15/32	1-3/8	1-1/4	47/64
7/8	1-7/16	35/64	1-1/2	1-7/16	55/64
1	1-5/8	39/64	1-3/4	1-5/8	63/64
1-1/8	1-13/16	11/16	2	1-13/16	1-7/64
1-1/4	2	25/32	2	2	1-7/32
1-3/8	2-3/16	27/32	2-1/4	2-3/16	1-11/32
1-1/2	2-3/8	15/16	2-1/4	2-3/8	1-15/32

**Table 1M - Bolt and Nut Dimensions (Metric)**

Heavy Hex Structural Bolts, mm

Nominal Bolt Size D	Width Across Flats, F		Height, H		Thread Length	
					for Bolt Lengths ≤100 mm	for Bolt Lengths >100 mm
	Max	Min	Max	Min	Max	Min
M16	27	26.16	10.75	9.25	31	38
M20	34	33	13.4	11.6	36	43
M22	36	35	14.9	13.1	38	45
M24	41	40	15.9	14.1	41	48
M27	46	45	17.9	16.1	44	51
M30	50	49	19.75	17.65	49	56
M36	60	58.8	23.55	21.45	56	63

## Heavy Hex Nuts, mm

Nominal Size, D	Width Across Flats, W		Height, H	
	Max	Min	Max	Min
M16	27	26.16	17.1	16.4
M20	34	33	20.7	19.4
M22	36	35	23.6	22.3
M24	41	40	24.2	22.9
M27	46	45	27.6	26.3
M30	50	49	30.7	29.1
M36	60	58.8	36.6	35.0

**2.4.3.2 Threads.** Threads for bolts and nuts shall conform to the following:

		Thread Tolerances	
		External	Internal
ENGLISH			
Unified Coarse Thread Series, UNC	ANSI/ASME B1.1	2A	2B
METRIC			
Metric Coarse Thread Series	ANSI/ASME B1.13M	6H	6g

The 8-pitch thread series 8 UN (3-pitch metric coarse thread series) shall be used on bolts larger than 1 in (M24).

### 2.4.3.3 Bolts.







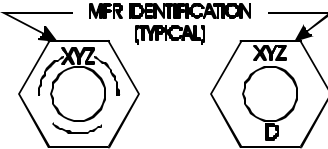

**2.4.3.3.1 Hardness.** Hardness for bolt sizes 1/2 to 1 in (M16 to M36) inclusive shall be as noted below:

Bolt Size	ASTM A325 (A 325M) Bolts			
	Hardness Number			
	Vickers		Rockwell C	
	Min.	Max.	Min.	Max.
1/2 to 1 in (M16 to M36)	253 (255)	319 (336)	25 (23)	33 (33)

**2.4.3.3.2 Bolt markings.** All bolts shall be identified with an “A 325” (“A 325M”) marking on the top of the bolt head and also a symbol identifying the manufacturer (see Fig. 2). Type 3 bolts shall be identified by an underlined “A 325”. In addition, Type 1 metric bolts shall be marked “8S”, and Type 3 metric bolts shall be marked “A 325M” and “8S3”.

**2.4.3.3.3 Bolt length.** The required bolt length shall be determined by adding the value shown in Table 2 to the grip (i.e. the total thickness of all connected material, without washers). For each hardened flat washer that is used add 5/32 in (4 mm), and for each beveled washer add 5/16 in (8 mm). The values of Table 2 provide appropriate allowance for manufacturing tolerances, and also provide for full thread engagement (i.e. having the end of the bolt at least flush with the face of the nut) with an installed heavy hex nut. The length thus determined shall be adjusted to the next longer standard (1/4 in) length.

SECTION 550

TYPE	A 325		A 490	
	BOLT	NUT	BOLT	NUT
1	(1) 	MFR IDENTIFICATION (TYPICAL)  ARCS INDICATE GRADE C GRADE MARK (2) D, DH, 2 OR 2H		 DH OR 2H (2)
2	WITHDRAWN N 1991	SAME AS TYPE 1	 NOTE MANDATORY 6 RADIAL LINES AT 30°	SAME AS TYPE 1
3	(3)  NOTE MANDATORY UNDERLINE	 	(3)  NOTE MANDATORY UNDERLINE	

(1) ADDITIONAL OPTIONAL 3 RADIAL LINES AT 120° MAY BE ADDED.







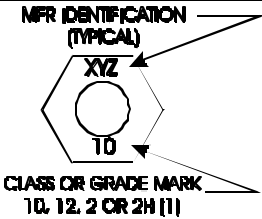

(2) TYPE 3 ALSO ACCEPTABLE

(3) ADDITIONAL OPTIONAL MARK INDICATING WEATHERING GRADE MAY BE ADDED.

FIGURE 2E - REQUIRED MARKING FOR BOLT AND NUT ASSEMBLIES

Table 2E - Bolt Lengths (English)

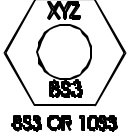
Nominal Bolt Size, Inches	To Determine Required Bolt Length Add to Grip, Inches
1/2	11/16
5/8	7/8
3/4	1
7/8	1-1/8
1	1-1/4
1-1/8	1-1/2
1-1/4	1-5/8
1-3/8	1-3/4
1-1/2	1-7/8

TYPE	A 325M		A 490M	
	BOLT	NUT	BOLT	NUT
1	(1) 			
2		SAME AS TYPE 1		SAME AS TYPE 1
3	(2) 	(2) 	(2) 	

(1) TYPE 3 ALSO ACCEPTABLE

(2) ADDITIONAL OPTIONAL MARK INDICATING WEATHERING GRADE MAY BE ADDED.

FIGURE 2 - REQUIRED MARKING FOR BOLT AND NUT ASSEMBLIES

Table 2 - Bolt Lengths (Metric)

Nominal Bolt Size, mm	To Determine Required Bolt Length Add to Grip, mm
M16	22
M20	25
M22	29
M24	32
M27	38
M30	41
M36	48

#### 2.4.3.4 Nuts.

##### 2.4.3.4.1 Plain nuts. Plain (ungalvanized) nuts shall conform to the following requirements.

Plain (ungalvanized) nuts [English] shall be grades C (recommended). Grades D, C3 with a minimum Rockwell hardness of 89 HRB [or Brinell hardness 180 HB], or DH or DH3 are suitable alternatives.

## SECTION 550

**2.4.3.4.2 Weathering nuts.** Nuts used with AASHTO M 164, ASTM A 325 (AASHTO M 164M, ASTM A 325M) Type 3 bolts shall be grade C3 (class 8S3) recommended or DH3 as a suitable alternative

**2.4.3.4.3 Nut markings.** Nuts shall be marked with the corresponding grade symbol 2, 2H, D, DH, or DH3 (class symbol 8S or 8S3) on one face. Grade C nuts shall be marked on one face with three circumferential marks 120 degrees apart. Grade C3 nuts shall be marked the same as class grade C nuts along with the numeral 3.

**2.4.3.4.4 Galvanized nuts.** Nuts to be galvanized shall be grade DH (class 10S).

**2.4.3.4.5 Overtapping nuts to be galvanized.** Nuts that are to be galvanized shall be tapped oversize the minimum amount required for proper assembly. The amount of overlap in the nut shall be such that the nut will assemble freely on the bolt in the coated condition and shall meet the overtapping requirements of AASHTO M 291, ASTM A 563 (AASHTO M 291M, ASTM A 563M) and the required rotational-capacity test.

**2.4.3.4.6 Lubrication.** Galvanized nuts shall be lubricated with a lubricant containing a water soluble visible dye of a color that contrasts with the color of the galvanizing.

**2.4.3.5 Washers.** Type 3 washers shall be used with AASHTO M 164, ASTM A 325 (AASHTO M 164M, ASTM A 325M) Type 3 bolts and shall be identified with the numeral 3 stamped on one face.

**2.4.3.5.1** Circular hardened washers shall be flat and smooth and their nominal dimensions shall conform to the dimensions given in Table 3. Where necessary, washers may be clipped on one side to a point not closer than 7/8 of the bolt diameter from the center of the washer.

**Table 3E - Dimensions for Hardened Washers F436<sup>a</sup> (English)**

Bolt D	Circular Washers				Square Beveled Washers for American Standard Beams and Channels		
	Nominal Outside Diameter	Nominal Diameter of Hole	Thickness		Minimum Side Dimension	Mean Thickness	Slope or Taper in Thickness
			Min	Max			
1/2	1-1/16	17/32	0.097	0.177	1-3/4	5/16	1:6
5/8	1-5/16	21/32	0.122	0.177	1-3/4	5/16	1:6
3/4	1-15/32	13/16	0.122	0.177	1-3/4	5/16	1:6
7/8	1-3/4	15/16	0.136	0.177	1-3/4	5/16	1:6
1	2	1-1/8	0.136	0.177	1-3/4	5/16	1:6
1-1/8	2-1/4	1-1/4	0.136	0.177	2-1/4	5/16	1:6
1-1/4	2-1/2	1-3/8	0.136	0.177	2-1/4	5/16	1:6
1-3/8	2-3/4	1-1/2	0.136	0.177	2-1/4	5/16	1:6
1-1/2	3	1-5/8	0.136	0.177	2-1/4	5/16	1:6
1-3/4	3-3/8	1-7/8	0.178 <sup>b</sup>	0.28 <sup>b</sup>			
2	3-3/4	2-1/8	0.178 <sup>b</sup>	0.28 <sup>b</sup>			
Over 2 to 4 incl.	2D-1/2	D+1/8	0.24 <sup>c</sup>	0.34 <sup>c</sup>			

<sup>a</sup>Dimensions in inches. (Tolerances as noted in Table 2, AASHTO M 293 ASTM F 436.)

<sup>b</sup>3/16 in. nominal. <sup>c</sup>1/4 in. nominal.

**Table 3M - Dimensions for Hardened Washers F 436M<sup>a</sup> (Metric)**

Bolt Size	Circular Washers					
	Outside Diameter		Inside Diameter		Thickness	
	Max	Min	Max	Min	Max	Min
M16	34	32.4	18.4	18	4.6	3.1
M20	42	40.4	22.5	22	4.6	3.1
M22	44	42.4	24.5	24	4.6	3.4
M24	50	48.4	26.5	26	4.6	3.4
M27	56	54.1	30.5	30	4.6	3.4
M30	60	58.1	33.6	33	4.6	3.4
M36	72	70.1	39.6	39	4.6	3.4

Square or Rectangular Beveled Washers  
for American Standard Beams and Channels

Bolt Size	Side Dimension		Mean Thickness		Slope or Taper in Thickness
	Max	Min	Max	Min	
M16	45.0	43.0	8.5	7.5	1:6
M20	45.0	43.0	8.5	7.5	1:6
M22	45.0	43.0	8.5	7.5	1:6
M24	45.0	43.0	8.5	7.5	1:6
M27	58.0	56.0	8.5	7.5	1:6
M30	58.0	56.0	8.5	7.5	1:6
M36	58.0	56.0	8.5	7.5	1:6

<sup>a</sup> Dimensions in inches. (Tolerances as noted in Table 4, AASHTO M 293 ASTM F 436.)

#### 2.4.4 Testing.

##### 2.4.4.1 Testing Bolts.

**2.4.4.1.1 Proof load test.** Proof load tension tests of full size bolts are required in accordance with Method 1, Length Measurement, of ASTM F 606 (ASTM F 606M). The minimum frequency of tests shall be as specified in AASHTO M 164, ASTM A 325 paragraph 9.2.4 (AASHTO M 164M, ASTM A 325M paragraph 9.3.4).

**2.4.4.1.2 Wedge test.** Wedge tension tests, ASTM F 606 (ASTM F 606M) paragraph 3.5, on full size bolts are required in accordance with AASHTO M 164, ASTM A 325 paragraph 10.1.1 (AASHTO M 164M, ASTM A 325M paragraph 9.1)). If bolts are to be galvanized, tests shall be performed after galvanizing. The minimum frequency of tests shall be as specified in AASHTO M 164, ASTM A 325 (AASHTO M 164M, ASTM A 325M).

**2.4.4.1.3** If galvanized bolts are supplied, the thickness of the zinc coating shall be measured. Measurements shall be taken on the wrench flats or top of bolt head.

##### 2.4.4.2 Testing Nuts.

**2.4.4.2.1 Proof load test.** Proof load tension tests are required for nuts in accordance with paragraph 4.2 of ASTM F 606 (ASTM F 606M). The minimum frequency of tests shall be as specified in AASHTO M 291, ASTM A 563 (AASHTO M 291M, ASTM A 563M) paragraph 8.3 or AASHTO M 292/M 292M (ASTM A 194/A 194M) paragraph 7.1.2.1. If nuts are to be galvanized, tests shall be performed after galvanizing, overtapping and lubricating.

**SECTION 550**

**2.4.4.2.2** If galvanized nuts are supplied, the thickness of the zinc coating shall be measured. Measurements shall be taken on the wrench flats.

**2.4.4.3 Testing Galvanized Washers.**

**2.4.4.3.1** If galvanized washers are supplied, hardness testing shall be performed after galvanizing. (Coating shall be removed prior to taking hardness measurements.)

**2.4.4.3.2** If galvanized washers are supplied, the thickness of the zinc coating shall be measured.

**2.4.4.4 Rotational-capacity test for fastener assemblies.** Rotational-capacity tests are required and shall be performed on all black or galvanized (after galvanizing) bolt, nut and washer assemblies by the manufacturer or distributor prior to shipping. Washers are required as part of the test. The following shall apply:

**2.4.4.4.1** Except as modified herein, the rotational-capacity test shall be performed in accordance with the requirements of AASHTO M 164, ASTM A 325 (AASHTO M 164M, ASTM A 325M).

**2.4.4.4.2** Each combination of bolt production lot, nut lot, and washer lot shall be tested as an assembly.

**2.4.4.4.3** A rotational-capacity lot number shall be assigned to each combination of lots tested.

**2.4.4.4.4** The minimum frequency of testing shall be two assemblies per rotational-capacity lot.

**2.4.4.4.5** The bolt, nut and washer assembly shall be assembled in a Skidmore-Wilhelm Calibrator or an acceptable equivalent device. For short bolts which are too short to be assembled in the Skidmore-Wilhelm Calibrator, see section 2.4.4.4.9.

**2.4.4.4.6** The minimum rotation, from a snug tight condition (10% of the specified proof load), shall be:

240 deg. (2/3 turn)	for bolt lengths	≤ 4D
360 deg. (1 turn)	for bolt lengths	> 4D and < 8D
480 deg. (1-1/3 turn)	for bolt lengths	> 8D

Notes:

1. The bolt length is measured from the underside of the head to the end of the bolt.
2. D = nominal bolt diameter (inches).

**2.4.4.4.7** The tension reached at the above rotation shall be equal to or greater than 1.15 times the required minimum bolt installation tension. Assemblies which do not meet this tension fail the test. The minimum bolt installation tension and the required tension for the turn test are shown below:

ENGLISH Bolt Diameter (Inches)	1/2	5/8	3/4	7/8	1	1-1/8	1-1/4	1-3/8	1-1/2
Min. Req'd. Bolt Installation Tension (kips)	12	19	28	39	51	56	71	85	103
Req'd Turn Test Tension (kips)	14	22	32	45	59	64	82	98	118

METRIC Bolt Size	M16	M20	M22	M24	M27	M30	M36
Min. Req'd. Bolt Installation Tension (kN)	94.2	147	182	212	275	337	490
Turn Test Tension (kN)	108	169	209	244	316	388	564

**2.4.4.4.8** After the required minimum bolt installation tension listed above has been exceeded, one reading of tension and torque shall be taken and recorded. The torque value shall conform to the following:

$$\text{Torque} \leq 0.25 PD$$

where, Torque = measured torque, foot-pounds (newton-meters)  
P = measured bolt tension, pounds (newtons)  
D = bolt diameter, feet (meters)

**2.4.4.4.9** Bolts that are too short to test in a Skidmore-Wilhelm Calibrator may be tested in a steel joint. The tension requirement of section 2.4.4.4.7 need not apply. The maximum torque requirement of section 2.4.4.4.8 shall be computed using a value of P equal to the turn test tension shown in the table in section 2.4.4.4.7.

#### **2.4.4.5 Reporting.**

**2.4.4.5.1 Results.** The results of all tests (including zinc coating thickness) required herein and in the appropriate AASHTO specifications shall be recorded on the appropriate document.

**2.4.4.5.2 Location.** The location where tests are performed and date of tests shall be reported on the appropriate document.

**2.4.4.6 Witnessing.** The tests need not be witnessed by an inspection agency; however, the manufacturer or distributor that performs the tests shall certify that the results recorded are accurate.

#### **2.4.5 Documentation.**

##### **2.4.5.1 Mill Test Reports.**

**2.4.5.1.1** Mill test reports shall be furnished for all mill steel used in the manufacture of the bolts, nuts, or washers.

**2.4.5.1.2** Mill test reports shall indicate the place where the material was melted and manufactured.

##### **2.4.5.2 Manufacturer Certified Test Reports - (MCTR).**

**2.4.5.2.1** The manufacturer of the bolts, nuts, and washers shall furnish test reports (MCTR) for the item furnished.

## SECTION 550

**2.4.5.2.2** Each MCTR shall show the relevant information required in accordance with 2.4.4.5.

**2.4.5.2.3** The manufacturer performing the rotational-capacity test shall include on the MCTR:

- (a) The lot number of each of the items tested.
- (b) The rotational-capacity lot number as required in 2.4.4.4.3.
- (c) The results of the tests required in 2.4.4.4.
- (d) The pertinent information required in 2.4.4.5.2.
- (e) A statement that MCTR for the items are in conformance to this specification and the appropriate AASHTO specifications.
- (f) The location where the bolt assembly components were manufactured.

### **2.4.5.3 Distributor Certified Test Reports - (DCTR).**

**2.4.5.3.1** The DCTR shall include MCTR above for the various bolt assembly components.

**2.4.5.3.2** The rotational-capacity test may be performed by a distributor (in lieu of a manufacturer) and reported on the DCTR.

**2.4.5.3.3** The DCTR shall show the results of the tests required in 2.4.4.4.

**2.4.5.3.4** The DCTR shall also show the pertinent information required in 2.4.4.5.2.

**2.4.5.3.5** The DCTR shall show the rotational-capacity lot number as required in 2.4.4.4.3.

**2.4.5.3.6** The DCTR shall certify that the MCTR are in conformance to this specification and the appropriate AASHTO specifications.

### **2.4.6 Shipping.**

**2.4.6.1** Bolts, nuts, and washers from each rotational-capacity lot shall be shipped in the same container. If there is only one production lot number for each size of nut and washer, the nuts and washers may be shipped in separate containers. Each container shall be permanently marked with the rotational-capacity lot number such that identification will be possible at any stage prior to installation.

**2.4.6.2** The appropriate mill test reports, MCTR or DCTR shall be supplied to the State with two copies of each.

**2.5 Anchor rods.** Anchor rods for bridge shoes shall be fabricated from deformed billet-steel concrete-reinforcement bars conforming to AASHTO M 31 (AASHTO M 31M), ASTM A 615/A 615M-96a, Grade 60 (400). As an alternative, anchor rods shall conform to ASTM A449 material (all-thread for diameters up to 1 1/2 inch (38 mm) and swedged for diameters over 1 1/2 in. (38 mm).

**2.5.1** The details of the anchor rods shall be as shown on the plans. Threads shall be cut or rolled into the specified length of the bar which has been turned to a uniformly circular cross-sectional area of the specified diameter. Anchor rod threads shall be metric coarse thread series, 6H tolerance (UNC-2A) as specified in ANSI/ASME B1.1 (ANSI/ASME B1.13M). Bars shall be furnished as follows:

Specified Thread Diameter	Reinforcing Bar Size
1 in (24 mm)	No. 9 (29)
1-1/4 in (30 mm)	No. 11 (36)
1-1/2 in (36 mm)	No. 14 (43)

**2.5.2 Nuts.** Nuts shall be hex nuts with mechanical properties conforming to ASTM A307. Threads for nuts shall be metric coarse thread series, UNC-2B (6g tolerance) as specified in ANSI/ASME B1.13M (ANSI/ASME B1.1).

**2.5.3 Washers.** Washers shall be circular washers of commercial quality, unless otherwise specified.

**2.5.4 Galvanizing.** Anchor rods, nuts, and washers shall be galvanized after fabrication and conform to AASHTO M 232 (ASTM A 153).

## **2.6 Preformed Fabric Bearing Pads.**

**2.6.1 Type 1.** Preformed fabric bearing pads shall meet the requirements of AASHTO Standard Specifications for Highway Bridges, Division II, Section 18.4.9.1 “Fabric-reinforced Elastomeric Bedding Pads” and MIL-C-882 and be a products as included on the Qualified Products List. Pads used to set bridge bearing masonry plates on concrete masonry (see 3.15.5) shall be a single sheet approximately 1/8 in (3 mm) thick.

**2.6.1.1** The preformed fabric pads shall be composed of multiple layers of 8 oz (244 grams per square meter) cotton or cotton-polyester 50-50 blend duck impregnated and bound with high-quality natural rubber or of equivalent and equally suitable materials compressed into resilient pads of uniform thickness and vulcanized. The number of plies shall be such as to produce the specified thickness after compression vulcanizing. The finished pads shall withstand compression loads perpendicular to the plane of the laminations of not less than 10,000 psi (70 Mpa) without detrimental reduction in thickness or extrusion.

**2.6.1.2** The thread filling count of the duck shall be  $40 \pm 2$  threads per 1 in (25 mm) and the warp count shall be  $50 \pm 1$  threads per 1 in (25 mm). The pad shall meet the requirements of the load deflection and permanent set compression tests. A certificate of compliance stating that the material complies with MIL-C-882 shall be supplied and shall accompany actual results of the above tests.

**2.6.2 Type 2.** Preformed fabric bearing pads with a polytetrafluorethylene (PTFE) surface for use in expansion bearing assemblies shall consist of the following two components:

- (1) a Type 1 preformed fabric pad meeting the requirements of 2.6.1 of a thickness specified on the plans;
- (2) a PTFE bearing element conforming to the requirements of 2.10 and which is bonded to a rigid confining substrate. The substrate shall limit flow (elongation) of the confined PTFE to not more than 0.009 in (0.230 mm) under load of 2000 psi (14 Mpa) for 15 minutes at 78 °F (26 °C) for a 2 by 3 in (50 by 75 mm) test sample.

**2.6.3 Testing.** Test samples of Type 2 preformed fabric pads shall be furnished to the Bureau of Materials and Research at least 14 days prior to structural steel erection. Three samples shall be furnished with the bonded PTFE surface and three samples shall be furnished without the bonded PTFE surface. Each test sample shall be 2 in (50 mm) wide by 2 in (50 mm) long.

## SECTION 550

**2.7 Stainless steel plate.** Stainless steel for use in expansion bearing assemblies shall conform to ASTM A 240/A 240M Type 304 with a #8 mirror finish on the side in contact with the PTFE surface.

**2.8 Steel tubing.** Steel tubing shall conform to the requirements of ASTM A 500, Grade B or ASTM A 501.

**2.9 Galvanizing.** When galvanizing is shown on the plans or specified, it shall meet the requirements of AASHTO M 111 (ASTM A 123) for fabricated steel products, and AASHTO M 232 (ASTM A 153) for hardware items other than high strength bolts (such as anchor rods, nuts and washers).

### 2.9.1 Galvanizing Touch-up and repairs.

**2.9.1** Repair damaged galvanizing and bare steel surfaces in accordance with ASTM A780, Standard Practice for Repair of Damaged Hot-Dipped Galvanized Coatings, Annex A2. Thoroughly clean damaged areas to produce a clean, bare and dry bright metal surface with a roughened profile and feather into the edges of adjacent undamaged galvanizing. Use a power sanding disk per SSPC-SP3. For bolts use a thorough wire brushing and SP1 cleaning as a minimum.

**2.9.2** Apply an approved organic zinc-rich repair paint containing 92 percent (min.) zinc by weight in the dry film, according to the manufacturer's recommendations, in two to four coats to a thickness equivalent to the surrounding galvanizing. The total repair area shall be less than 3% of the area of the member, or the member shall be rejected and regalvanized. Repair paints shall be approved. The repair paint may be a liquid and brushed on or an aerosol and sprayed, whichever is appropriate to achieve an aesthetic finish and as long as the minimum thickness of the original system and cure are achieved. The Contractor shall provide a dry film thickness gage and check the thickness of the repair areas. Touch-ups shall be such that the repair is not noticeably visible from a distance of six feet.

**2.10 PTFE surfaces for bearings.** PTFE for use in expansion bearing assemblies shall be 100 percent virgin (unfilled) polytetrafluorethylene polymer conforming to AASHTO Standard Specifications for Highway Bridges (AASHTO), Division I, Section 14.6.2 "PTFE Sliding Surfaces" and AASHTO, Division II, Section 18.4.3 "Special Material Requirements for PTFE Sliding Surfaces" and Section 18.5.3 "Special Fabrication Requirements for PTFE Sliding Bearings".

## Construction Requirements

### 3.1 General.

#### 3.1.1 Specifications.

**3.1.1.1** Fabrication, painting, transportation and erection of steel structures shall conform to the latest edition and interim Specifications of the AASHTO "Standard Specifications for Highway Bridges" (Division II Construction) unless otherwise specified herein.

**3.1.1.2** Welded fabrication shall conform to the AASHTO Welding Specifications, namely, the latest edition of the AASHTO/AWS D1.5 "Bridge Welding Code" and all Interim Revisions published by AASHTO as of the bid opening date, unless otherwise specified herein.

#### 3.1.2 Guidelines.

**3.1.2.1** The latest edition of the following AASHTO/NSBA\_Steel Bridge Collaboration documents shall provide procedural guidance to the work unless directed otherwise in the governing specifications or by the Department:

- (a) G1.1 Shop Detail Drawings Review/Approval Guidelines
- (b) G1.2 Design Drawing Presentation Guidelines
- (c) G1.3 Shop Detail Drawing Presentation Guidelines
- (d) S2.1 Steel Bridge Fabrication Guide Specification
- (e) S4.1 Steel Bridge Fabrication QC/QA Guide Specification
- (f) S8.1 Guide Specification for Coating Systems with Inorganic Zinc-Rich Primer
- (g) G9.1 Steel Bridge Bearing Design and Detailing Guidelines
- (h) G12.1 Guidelines for Design for Constructability

**3.1.3 Approval.** Prior to performing any work under 550, the fabricator must have received approval for all shop fabrication drawings, welding procedures, and any special Contract requirements. The fabricator shall bear full responsibility and costs for all materials ordered or work performed prior to approval of the shop fabrication drawings or written authorization to proceed from the Engineer.

**3.1.4 Quality of workmanship and finish.** The workmanship and finish shall be first class and equal to the best practice in modern bridge shops. Shearing, flame cutting, bolting, and welding shall be neatly and accurately done, and all portions of the work exposed to view shall be neatly finished.

**3.1.5 Main members.** The main members of steel structures are defined to include but not be limited to rolled beams, girder flange and web plates, truss components, arches, floor beams, stringers, bridge shoes, cross frames carrying direct live loads, cover plates, bearing stiffeners, longitudinal stiffeners, transverse stiffeners, splice plates, cross frames on horizontally curved bridges, and end connecting or gusset plates for any of these members. The Contract plans may also designate other members as main members.

**3.2 Fabricator qualification.** Structural steel for bridges furnished under Section 550 shall be fabricated in a plant/shop that has established proof of its competency and responsibility by being registered and certified in accordance with the American Institute of Steel Construction, Inc. (AISC) Quality Certification Program.

**3.2.1 AISC Category - Major Steel Bridges (CBR).** AISC Category CBR Certification is required for the fabrication of bridge structures incorporating welded plate girders, trusses, arches, welded floorbeams, rolled beams with cover plates, rolled beams with bolted field splices, horizontally curved rolled beams, cross frames for curved bridges, and pot bearings. The fabrication of fracture critical members requires an AISC Fracture Critical Endorsement.

**3.2.2 AISC Category - Simple Steel Bridge Structures (SBR).** AISC Category SBR or CBR certification is required for the fabrication of simple straight unspliced rolled beam bridges, structural members for bridge repair or rehabilitation work, bridge shoes, high mast poles, sign bridges, cantilever sign supports, expansion joints, pedestrian truss bridges, scuppers, bridge rail, bridge approach rail, non-structural items, and ancillary members requiring minimal welding and fabrication.

**3.2.3 AISC Sophisticated Paint Endorsement P1 (enclosed).** Fabricators supplying painted or metalized main member products as a Category SBR or Category CBR shop shall be certified with the AISC Sophisticated Paint Endorsement.

### **3.3 Shop Fabrication Drawings.**

**3.3.1** The fabricator shall furnish shop fabrication drawings of all details of fabrication of all structural metals required under the Contract, for approval in accordance with 105.02. The shop fabrication drawings shall show details, dimensions, size and grade of materials, match marking diagrams for field connections, procedures, and other information necessary for the complete fabrication and erection of the work.

## SECTION 550

**3.3.2** Shop fabrication drawings shall meet the requirements of AASHTO 11.2.1. All shop fabrication drawings shall be neatly and accurately drawn. All shop fabrication drawings shall show both the detailer's and checker's initials as an indication that the details have been checked for accuracy.

**3.3.3** The shop fabrication drawings shall be furnished sufficiently in advance of fabrication to allow for review, resubmission, and approval by the Engineer.

**3.3.4** The shop fabrication drawings shall be furnished as a complete set for each structure. They may be furnished according to a sequence in partial sets if approved in advance by the Engineer.

**3.3.5** The fabricator shall submit three sets of the shop drawings to the Engineer for approval. After receiving approval, the fabricator shall supply the Engineer with six distribution sets of revised working drawings. If a design consultant is involved in the project, four approval sets and seven distribution sets of working drawings shall be supplied.

**3.3.6** Fabrication shall not begin until written approval of the submitted shop fabrication drawings has been received from the Engineer.

**3.3.7** Deviation from the approved shop fabrication drawings will not be permitted without the written order or consent of the Engineer.

**3.3.8** Detailed welding procedure specifications shall be considered an integral part of shop fabrication drawings and shall be submitted for approval along with the shop fabrication drawings. The shop fabrication drawings and welding procedures shall clearly indicate the welding procedure corresponding to each weld shown.

**3.3.9** The fabricator shall expressly understand that the Engineer's review of shop fabrication drawings submitted by the fabricator covers requirements for strength and arrangement of component parts, and the Engineer assumes no responsibility for errors in dimensions.

**3.3.10 Originals.** Original shop fabrication drawings, corrected 'as-built', shall be delivered to the Department before final payment will be made.

### **3.4 Material Identification.**

**3.4.1** The identification of steels during fabrication shall be according to AASHTO 11.4.1, except that steel stamping shall not be used for material identification.

#### **3.4.2 Mill Test Reports.**

**3.4.2.1** Two copies of certified heat number identified mill test reports showing physical test results and chemical analysis for all main and secondary structural members shall be furnished to the Engineer. Mill test reports shall be traceable to the piece mark and identified by the State project name, project number, and bridge number.

**3.4.2.2** Any material not properly identified shall not be incorporated in the work.

**3.4.2.3** Receipt of acceptable mill test reports by the Inspector is required before fabricated material may be released for shipment. Receipt of acceptable mill test reports by the Engineer is a prerequisite for payment for any fabricated material.

**3.4.3 Substitutions.** Materials other than those shown on shop fabrication drawings reviewed by the Engineer may be used under the following provisions:

- (a) that the substitute material is equal or greater in strength and properties to the material originally shown;
- (b) that the substitution is approved by the Engineer; and
- (c) that the substitution is made at no additional cost to the Department.

### 3.4.4 Die Stamping.

**3.4.4.1** Die stamping shall not be permitted on main members for radiographic testing, welder identification, heat number transfer or quality assurance acceptance. Girder piece marks may be made with low stress stamps on the web at mid-depth at the end of the girder and on splice plates outside the bolt pattern, or as approved.

**3.4.4.2** When die stamping is permitted, low stress dies (i.e. dies manufactured to produce impressions that are rounded at the bottom of the impression rather than sharp edged) shall be used and shall conform to the following requirements:

Nominal Character Size inches (mm)	Minimum Character Face Radius inches (mm)
1/8 (3)	0.007 (0.18)
3/16 (4.5)	0.008 (0.20)
1/4 (6)	0.01 (0.25)

### 3.5 Preparation of Base Metals.

**3.5.1** Thermal cutting of structural steel shall conform to the requirements of the AASHTO Welding Specifications. Thermal cutting of main members shall be done only when the steel in the area of the cut is above 40 °F (4 °C) and in a surface-dry condition except when using plasma arc.

**3.5.2** All thermal cut surfaces shall be produced using a mechanically guided torch, unless otherwise approved. Thermal cut surfaces produced by manually guided torch, when allowed, shall be made with a suitable guiding device and be smoothed by grinding.

**3.5.3 Reentrant corners.** Reentrant corners shall be formed to a radius of not less than 1 in (25 mm). On main material a 2 in (50 mm) minimum radius shall be provided whenever possible. All reentrant corner edges shall be ground to a 1/16 in (1.5 mm) radius.

**3.5.4 Thermal cutting of high strength steel, 50 ksi (345 MPa) min. yield strength.** The fabricator shall take steps to insure that the thermal cut edges of main material subject to tensile stresses are not hardened by the cutting process. This may be achieved by preheating, post heating or control of the burning process. Flame cut edges of webs which are incorporated into final submerged arc web-to-flange fillet welds need not be tested for hardness.

**3.5.4.1** Thermal cut edges found to have a Rockwell Hardness Value of C30 or greater will be considered unacceptable. A portable Rockwell Hardness Tester will be employed by the fabricator and witnessed by the Inspector to determine conformance with these requirements. Unacceptably hard surfaces shall be removed by grinding, machining, or approved heat treating procedures.

**3.5.4.2** All Rockwell Hardness testing shall be performed on the thermal cut edge at the mid-thickness location of the plate. Testing shall be performed randomly along the length of each plate.

## SECTION 550

**3.5.5 Weld repairs.** Approved weld repairs of notches and gouges in thermal cut plate edges shall be performed in accordance with the requirements of the AASHTO Welding Specifications and 3.6.9.

**3.5.6 Facing of bearing surfaces.** The surface finish of bearings shall meet the requirements of AASHTO 11.4.6.

**3.5.6.1** Sliding bearings with a surface roughness greater than ANSI 60 shall be machined or ground or machined and ground so that the lay of the cut does not restrict movement in the longitudinal direction. This includes the rotating portion of the top of rockers and rocker sockets in sole plates.

**3.5.7 Flange plates.** All flange plates shall be furnished with either thermal cut edges or Universal Mill plates. When thermal cutting flange plates, both edges shall be cut simultaneously to minimize distortion.

**3.5.8 Web plates.** Web plates of built up girders shall be thermal cut to produce the required camber.

**3.5.9 Splice plates and gusset plates.** Flange and web splice plates shall be furnished with thermal cut edges, although web splice plates 5/8 in (16 mm) or less in thickness may be made of sheared plates.

**3.5.10 Stiffeners and connection plates.** Stiffeners and connection plates welded transverse to girder webs and flanges may be furnished with sheared edges provided their thickness does not exceed 5/8 in (16 mm). Universal Mill plate may be used provided its thickness does not exceed 1 in (25 mm). All other stiffener and connection plates shall be furnished with thermal cut edges.

### **3.5.11 Bending of Structural Steel.**

**3.5.11.1 Heat bending.** Unless otherwise approved, cold or low-heat bending of main material is not permitted. To facilitate bending, the steel shall be heated between 900° and 1,150 °F (480° and 625 °C) over the entire area and cross section to be bent. Heating methods and equipment shall be as described in 550.3.10.

**3.5.11.2 Bending flange plates.** When flange plates are required to be bent to a radius of 2 ft (600 mm) or less, the area to be bent shall be heated for the full width of the flange and for a length of at least six times the thickness of the flange. No bending force shall be applied until this entire area is heated to a temperature between 900° and 1,150 °F (480° and 625 °C). After bending is complete, and the temperature of the plate has cooled to ambient temperature, all surfaces of the heated area shall be magnetic particle inspected.

**3.5.11.3 Cold-bent plates.** Unwelded, cold-bent plates of secondary members, such as cross frame gusset plates on a skewed bridge, shall conform to AASHTO 11.4.3.3.2. Bending shall be such that no cracking of the plate occurs. Before bending, the corners of the plate shall be rounded to a radius of 1/16 in (1.5 mm ) throughout the portion of the plate at which the bending is to occur.

## **3.6 Shop Welding.**

### **3.6.1 Welding Procedures.**

**3.6.1.1** The fabricator shall submit welding procedure specifications to the Administrator, Bureau of Bridge Design and receive written approval of the procedures prior to the start of fabrication.

**3.6.1.2** All welding shall conform to the approved welding procedure specifications.

**3.6.1.3** Welding procedures shall be provided to the welders and welding operators and shall be posted on welding machines for use during production.

**3.6.1.4 Welding Procedure Specifications.** Form III-2 of Annex III of the AASHTO Welding Specifications shall be required for use in both qualified and prequalified written welding procedure specifications.

### **3.6.2 Qualification of Welders and Welding Operators.**

**3.6.2.1** Welding shall be performed by only prequalified welders, welding operators, and tackers, and shall be qualified by the applicable tests as described in the AASHTO Welding Specifications.

**3.6.2.2** Welder and welding operator qualification tests shall be the responsibility of the fabricator. However, the qualification tests shall be witnessed and approved by an independent, qualified testing/inspection agency.

**3.6.2.3** The fabricator shall maintain a file of the welder and welding operator qualification test records and make this file available for examination to the Administrator, Bureau of Bridge Design, upon request. Welder qualification test records shall be Form III-4 of Annex III of the AASHTO Welding Specifications or equal.

**3.6.2.4** For each project, the fabricating shop shall submit a letter of compliance to the Engineer listing by name all welders and welding operators employed on the fabrication of material for the project. The letter shall certify that these welders or welding operators have been prequalified and that they have been continuously engaged in the welding process for which they are qualified with no lapses in such employment in excess of 6 months since being prequalified.

### **3.6.3 Welding Processes.**

**3.6.3.1 Main members.** Welding of main load-carrying members and attachments (3.1.5) shall be performed using only submerged arc (SAW) and shielded metal arc processes (SMAW).

**3.6.3.2 Submerged arc welding.** All principal welds on main members shall be made with the submerged arc process, including all welding of butt splices, flange-to-web welds, connection or stiffener plates to webs, and attaching cover plates.

#### **3.6.3.3 Shielded Metal Arc Welding.**

**3.6.3.3.1** The use of the manual shielded metal-arc process shall be limited to welding connection plates to rolled beams, welding bridge shoes, repairs, tack welding, joints under 2 ft (600 mm) in length, minor detail attachments, and other limited welding applications where the use of submerged arc welding equipment is impractical because of limited access or the isolated location and short length of welds involved. Shielded metal arc welding may be used for submerged arc weld repairs.

**3.6.3.3.2** Only low hydrogen electrodes will be allowed. Proper electrode storage must be strictly adhered to according to the AASHTO Welding Specifications.

**3.6.3.4 Flux cored arc welding.** The flux cored arc welding process (FCAW) may be used for members which are not main load-carrying members, such as bridge shoes, cross frames, diaphragms, steel bridge rail, steel light poles, scuppers, expansion joints, and approved secondary material, unless directed otherwise.

## SECTION 550

**3.6.3.5 Gas metal arc welding.** The gas metal arc welding process (GMAW) may be used for welding the products listed in 3.6.3.4, unless directed otherwise.

**3.6.3.6** Electroslag (ESW) and electrogas (EGW) welding processes is not permitted.

**3.6.3.7 Calibration.** The fabricator shall periodically calibrate the amperage and voltage meters on welding machines, or, alternatively, verify meter readings by the use of a tong ammeter and volt meter external to the welding machine at regular intervals, or as requested by the Inspector.

**3.6.3.8 Arc strikes.** Arc strikes outside the area of permanent welds are prohibited on any base metal. Arc strikes are to be ground smooth, and on main member material the area shall be checked for soundness by magnetic particle testing at all locations.

### **3.6.4 Welding AASHTO M 270/M 270 M Grade 50 W (345W) (weathering) steel.**

**3.6.4.1 Deposited weld metal.** When AASHTO M 270/M 270M Grade 50 W (345W) is specified, deposited weld metal shall have the atmospheric corrosion resistance and coloring characteristics that matches that of the base metal.

**3.6.4.2 Minimum heat input.** The minimum heat input during welding of M 270/M 270M Grade 50W (345W) steel shall be determined by the procedure qualification test parameters.

**3.6.5 Preheat and interpass temperature.** Preheating is required for all welding when the temperature of the base metal is below the minimum specified in the AASHTO Welding Specifications (see Table 4). The base metal shall be preheated in such manner that the parts on which the weld metal is being deposited are above the specified minimum temperature for a distance equal to the thickness of the part being welded but not less than 3 in (75 mm) in all directions from the point of welding. In joints involving combinations of base metals, preheat shall be as specified for the higher strength metal being welded. Temperatures above the minimum specified may be required for highly restrained welds. Preheat temperatures shall be monitored at the locations specified above.

**Table 4 - Minimum Preheat and Interpass Temperature\***

Thickness of thickest part at point of welding	M 270/M 270M Gr 36 (Gr 250)
	M 270/M 270M Gr 50 (Gr 345)
	M 270/M 270M Gr 50W (345W)
	°F (°C )
To 3/4 in (19 mm)	50 (10)
Over 3/4 to 1-1/2 in (19 to 38 mm)	70 (20)
Over 1-1/2 to 2-1/2 in (38 to 64 mm)	150 (65)
Over 2-1/2 in (64 mm)	225 (110)

\* A minimum preheat temperature of 200°F (100°C) [max. 400°F (205 °C)] will be required for all field welding, irrespective of existing temperatures.

### 3.6.6 Weather Conditions.

**3.6.6.1** Welding shall not be performed when surfaces to be welded are wet from condensation, rain, snow or ice, when rain or snow is falling on the surfaces to be welded, or during periods of high wind unless the welder and the work are properly protected. Welding shall not be permitted when the ambient temperature is below 32 °F (0 °C). (The ambient temperature does not mean the ambient environmental temperature but the temperature in the immediate vicinity of the weld.)

**3.6.6.2** Shop areas for automatic and semiautomatic welding shall be kept at a temperature not lower than 40 °F (4 °C) for at least one hour before work begins and at all times when work is being performed.

### 3.6.7 Tack Welds.

**3.6.7.1** The provisions of the AASHTO Welding Specifications shall govern the use of tack welds.

**3.6.7.2** Temporary welds that are not incorporated into the final weld are not permitted, except as shown on the shop fabrication drawings and approved. All the quality requirements of final welds shall apply to such temporary welds including preheat. Temporary welds shall be removed by grinding smooth and flush, the area inspected by dye penetrant testing, and tested for hardness as required.

**3.6.7.3** Tack welds shall be thoroughly cleaned before final welding.

**3.6.7.4** Tack welds shall be sufficiently small to insure that they do not produce objectionable changes in the appearance of the weld surface or result in a decrease in penetration. Tack welds larger than permitted shall be reduced by grinding before final welding is begun.

**3.6.7.5** Unless otherwise approved, tack welds shall be made by E7018 electrodes.

**3.6.7.6** Tack welds that contain cracks shall be removed and rewelded before placing final welds.

**3.6.7.7** Preheat is required for tack welds which are remelted and incorporated into any final weld made by a process other than submerged arc.

### 3.6.8 Weld Terminations.

**3.6.8.1** Run-on and run-off extension plates. Welds shall be terminated (started and stopped) at the end of a joint in a manner that will insure sound welds. Whenever possible, this shall be done by the use of weld tabs (run-on and run-off extension plates) placed in a manner that will duplicate the joint detail being welded. Weld tabs shall be of sufficient length in the direction of the weld that potential crater cracks do not extend into the edge of the member, but not less than 2 in (50 mm).

**3.6.8.2 Weld tab installation.** Weld tabs shall be installed in a manner that will prevent cracks from forming in the area where the weld tab is joined to the member. The preferred method is by tack welding inside the joint where the tack welds will be consumed in producing the final weld.

**3.6.8.3 Weld tab removal.** Weld tabs shall be removed upon completion and cooling of the weld. The ends of the welds shall be made smooth and flush with the edges of the abutting parts. The edges of flanges and webs at the ends of groove-weld butt joints shall be inspected by dye penetrant testing.

## SECTION 550

**3.6.8.4 Fillet weld terminations.** All fillet welds must have full throat and no unfilled craters at the beginning and end of the weld. Fillet weld terminations shall have a smooth, rounded profile free of sharp irregularities. Grinding required to correct irregular profiles shall be done with a burr grinder.

### **3.6.9 Repairs.**

**3.6.9.1** Weld repairs shall be performed in accordance with the requirements of the AASHTO Welding Specifications.

**3.6.9.2 Approval.** Prior to performing any corrective weld repairs, the Fabricator shall submit a proposed repair procedure to the Department and receive approval. Prior approval does not have to be obtained in writing, unless required by the Engineer. However, a written record shall be made of all repair work performed and locations.

**3.6.9.3 Multiple repairs.** The maximum number of repairs to unacceptable defects in main member welds shall be three; i.e. the number of times a weld may be opened, repaired, and resubmitted for nondestructive testing, unless otherwise approved by the Administrator, Bureau of Bridge Design.

**3.6.9.4** Structural members shall not be accepted for placement in the structure until all repairs have been made and accepted.

**3.6.9.5 Preheat.** All weld repairs shall be performed with a minimum preheat and interpass temperature of 250 °F (120 °C).

**3.6.9.6 Air carbon-arc gouging.** Air carbon-arc gouging shall be followed by thorough grinding, that is, grinding to all-over bright metal.

**3.6.9.7 Testing.** All weld repairs in tension areas shall be inspected for soundness by dye penetrant testing and shall be retested by the method originally used. The repair of a repair (i.e. successive repairs in a given location) at a main member groove-weld location in tension shall be inspected for soundness by radiographic, ultrasonic and dye penetrant testing after waiting for an interval of 72 hours. All groove-weld repairs shall be ground smooth and flush prior to testing.

**3.6.10 Stud welding.** Studs shop welded to pier nose angles, scuppers and expansion joints as required on the plans shall meet the requirements of 547, Shear Connectors and AASHTO Welding Specifications, Chapter 7.

### **3.7 Shop Inspection.**

**3.7.1 Quality assurance inspection.** The Department will inspect the fabrication of structural steel on bridge projects which involve main load-carrying members, including welded girders and rolled beams. This quality assurance inspection will include the examination of materials, welding, nondestructive testing, work procedures, painting, and the final fabricated product.

**3.7.1.1** Fabrication shall only be done in the presence of an authorized inspector representing the Department. The Department's authorized quality assurance inspector is herein referred to as the Inspector.

**3.7.1.2** The Engineer may waive shop inspection for secondary structural components and make a complete inspection at a later stage in the construction sequence.

## SECTION 550

**3.7.2 Notice.** The fabricator shall give ample notice (two weeks minimum) of the beginning of work so that arrangements can be made for inspection. No materials shall be fabricated before the Engineer has been so notified.

**3.7.3 Authority.** The Inspector shall have the authority to reject any material or workmanship that does not meet the requirements of the contract documents. In case of dispute, the Contractor may appeal to the Engineer, whose decision shall be final.

**3.7.3.1** Inspection at the shop is intended as a means of facilitating the work and avoiding errors, and it is expressly understood that it will not relieve the fabricator from any responsibility in regard to imperfect material or workmanship and the necessity for replacing the same.

**3.7.4 Acceptance.** The Inspector shall affix the acceptance stamp of his company to the structural steel when it is ready for shipment and has been properly loaded. This acceptance mark shall be made by paint or ink stamp placed near the erection mark of the piece. Boxed or bundled material may be stamped on durable tags.

**3.7.4.1** Receipt of acceptable mill test reports by the Inspector and the completion of all inspections are prerequisite for fabricated material being approved and released for shipment.

**3.7.4.2** The fabricator shall present the Inspector with a copy of the shipping invoice to be stamped for verification of inspection and approval of steel items prior to shipment.

**3.7.4.3** The Inspector's acceptance implies that at the time of shipment from the shop, it was the opinion of the Inspector that the structural steel was fabricated from accepted materials by approved processes, painted and loaded for shipment in accordance with the contract requirements. The Inspector's stamp of approval for shipment does not imply that the structural material will not be rejected by the State if subsequently found to be defective.

**3.7.5 Facilities.** The fabricator shall furnish facilities for the quality assurance (QA) inspection of materials and workmanship in the shop. The facilities for inspection shall include office accommodations separate from fabricator personnel and convenient to the work equipped with adequate and working lighting, electrical outlets, heating, ventilation and if necessary air conditioning, a desk and chair, a metal file cabinet, plan rack, and a telephone available for the exclusive use of the Inspector. The fabricator shall provide and permit the QA inspector access to and use of a fax machine, digital camera, and email connections.

### **3.7.6 Cooperation.**

**3.7.6.1** The fabricator shall fully cooperate with the Inspector in the inspection of the work in progress. This shall include the storage of members completed during the Inspector's absence, in such a manner, that he can completely and safely inspect the finished work.

**3.7.6.2** The fabricator shall allow the Inspector unrestricted access to the necessary parts of the shop during working hours. Work done while the Inspector has been refused access shall be automatically rejected.

**3.7.6.3** The fabricator shall furnish the Inspector with as many copies of mill orders as may be requested.

**3.7.7 Testing.** The fabricator shall perform nondestructive testing required by the contract, the specifications, and as detailed in 3.8.

## SECTION 550

**3.7.7.1** Nondestructive testing shall only be done in the presence of the Inspector.

**3.7.7.2** The fabricator shall notify the Inspector 48 hours in advance if nondestructive testing is to be performed at times other than regular daylight hours of the regular work week.

**3.7.7.3** The fabricator shall comply with all requests of the Inspector to correct deficiencies in materials and workmanship as provided in the Contract documents.

### **3.8 Nondestructive Testing of Welds.**

**3.8.1 Responsibility.** The fabricator is responsible for providing nondestructive testing of welds, including equipment, supplies, and technicians. Nondestructive testing shall be performed as required by the AASHTO Welding Specifications.

**3.8.2 Personnel qualification.** Personnel performing and interpreting nondestructive tests (i.e. magnetic particle, dye penetrant, radiographic, and ultrasonic) shall be certified Level II individuals qualified in accordance with the American Society for Nondestructive Testing Recommended Practice No. SNT-TC-1A, or equivalent, as required by the AASHTO Welding Specifications.

**3.8.3 Witness.** Nondestructive testing shall be performed in the presence of the Inspector, unless permitted otherwise. The fabricator shall advise the Inspector of nondestructive testing schedules. The Inspector shall be given 48 hours advance notice of any nondestructive testing that is to be performed at times other than regular daylight hours of the regular work week. Radiographic test films shall be made available to the Inspector in a timely manner for review.

**3.8.4 Reports.** Nondestructive test reports shall be identified as to structure member and location of weld or welds and shall also list all the defective welds, the number of times defective welds were corrected, and the amount of additional inspection required. All radiographs shall become the property of the Department and shall be turned over to the Department on completion of the fabrication, or when otherwise requested by the Inspector.

**3.8.4.1 Forms.** Nondestructive testing shall be reported on forms from the Appendices of the AASHTO Welding Specifications, or equal. Use Annex 7 Form VII-11 for ultrasonic testing, Annex III Form III-5 for radiographic testing, and Form III-6 for magnetic particle testing.

**3.8.5 Zone of stress reversal.** For the purpose of determining nondestructive testing requirements in beams and girders, the zone of stress reversal shall be assumed to extend 10 ft (3 m) each side of the field splice location (or secondarily, the dead load point of contraflexure), unless otherwise detailed on the contract plans.

**3.8.6 Visual inspection.** All welds shall be visually inspected.

### **3.8.7 Magnetic Particle Testing.**

**3.8.7.1** Magnetic particle testing shall be performed on welds as described in the AASHTO Welding Specifications, including web-to-flange, bearing stiffener-to-web, cover plate to flange, bridge shoes, and cross frame welds and connection plate-to-web welds on horizontally curved girders.

**3.8.7.2** When magnetic particle testing is used, the procedure and technique shall be in accordance with the dry powder magnetic particle examination of welds using the yoke method or prod method in accordance with ASTM E 709.

**3.8.7.3 Yoke Method.** The yoke method shall be performed using half-wave rectified direct current electromagnetic yokes and shall have a lifting force of at least 50 lb (225 N) at the maximum pole spacing that will be used over four inches.

**3.8.7.4 Prod Method.** When the prod method is performed on AASHTO M 270/M 270M Gr 50 (345) or Gr 50W (345W) steel or other steels with a minimum specified yield strength of 50 ksi (345 MPa) or greater, aluminum prods shall be used on the test equipment. Copper prods shall not be used on such steels. Arcing shall be minimized by following the proper testing procedures.

**3.8.8 Radiographic testing.** Radiographic testing shall be performed on groove welded butt joints in main members. Radiographic testing shall be performed in accordance with the requirements of the AASHTO Welding Specifications, except that wire penetrometers shall not be permitted.

**3.8.8.1** All identification marks required on butt welds for radiographic purposes shall be made with paint. Steel die stamping shall not be permitted.

**3.8.8.2** Edge blocks shall be used when radiographing butt welds greater than 1/2 in (12 mm) thickness. The edge blocks shall have a length sufficient to extend beyond each side of the weld centerline for a minimum distance equal to the weld thickness, but not less than 2 in (50 mm), and shall have a thickness equal to or greater than the thickness of the weld. The minimum width of the edge blocks shall be equal to half the weld thickness, but not less than 1 in (25 mm). The edge blocks shall be centered on the weld against the plate being radiographed, allowing not more than 1/16 in (1.6 mm) gap for the minimum specified length of edge blocks. Edge blocks shall not be tack welded. Edge blocks shall be made of radiographically clean steel and the surface shall have a finish of 125 microinches (ANSI 3  $\mu$ m) or smoother.

**3.8.9 Ultrasonic testing.** Ultrasonic testing shall not be used as a substitute for radiographic testing. Ultrasonic testing may be used by the fabricator to determine the extent of discontinuities, laminations and inclusions discovered in any base metal.

**3.8.10 Dye penetrant testing.** Dye penetrant testing shall be used to inspect transverse fillet welds (3.9.3.2), ends of groove weld butt splices (3.6.8), weld repairs (3.6.9), arc strikes (3.6.3.8), and may be used to supply additional information at the discretion of the Inspector. Dye penetrant testing shall only be performed when the steel is between the temperatures of 40 to 110 °F (4 to 45 °C). After dye penetrant testing is completed and approved, discoloration shall be removed from the steel with suitable solvents.

### **3.9 Assembly of Shop Welded Connections.**

**3.9.1 Plate girder assembly.** Flange and web plates for welded girders shall be completely shop welded separately before assembly as shown on the plans.

**3.9.2 Butt splice welds.** All butt splice groove welds shall be made flush and smooth by grinding in the longitudinal direction of the girder.

### **3.9.3 Assembly of Vertical Stiffeners.**

**3.9.3.1** Intermediate stiffeners, bearing stiffeners, and connection plates shall be sniped at the corners and welded to the web and flanges as specified on the Contract plans. The fillet welds connecting the stiffener or connection plate to the web shall be started at the end of the stiffener that is adjacent to the tension flange and progress toward the compression flange. The fillet welds shall extend to within 1/2 in (12 mm) of all sniped corners and shall not be wrapped around the end of the plate in the sniped corner.

## SECTION 550

Care shall be taken to prevent the stiffener welds from intersecting the continuous flange to web welds. The maximum possible clearance between intersecting welds is desired. All fillet welds must have full throat and no unfilled craters at the beginning and end of the weld. Localized undercut of the stiffener at the point where the welding machine is started or stopped shall not require repair unless severe in the opinion of the Inspector.

**3.9.3.2 Undercut.** When fillet weld toe undercut is less than 1/32 in (1 mm) deep and transverse to the primary stress, the undercut may be corrected by grinding to a smooth profile not to exceed 1/32 in (1 mm) deep. Repair by grinding shall be inspected by dye penetrant testing.

**3.9.3.3** Before welding, there shall be no gap between the web and the intermediate stiffeners, bearing stiffeners, or connection plates in excess of 3/32 in (2.4 mm).

**3.9.3.4** Intermediate stiffeners and connection plates may be cut 3/16 in (5 mm) short and then assembled with the stiffener tight against the tension flange and the weld size at the compression flange increased to include the gap. Stiffeners shall not be driven in place with sufficient force to distort the flange, web or stiffener. Stiffeners which show evidence of being under compressive stress, such as waviness along the length of the stiffener after fitting is completed, shall be removed and corrected prior to final welding.

**3.9.3.5** Tack welds shall be so placed that weld passes do not start or stop on the tack weld.

**3.9.4 Bearings.** Sole plates of beams and girders shall have full contact with the flanges, and the bearing surface shall be smooth and true and shall be truly perpendicular to the web of the member. Curved sole plates shall make full-line bearing with masonry plates, which line, unless otherwise shown on the plans, shall be at right angles to the web of the member.

**3.9.4.1 Sole plates.** The sole plate-to-flange fillet welds which are on opposite sides of a common plane of contact shall not be wrapped but terminated 1/4 in (6 mm) short of the common corner.

**3.9.5** Longitudinal stiffener plates shall be continuous and shall be butt spliced, if required, with full penetration groove welds, and 100% inspected by radiographic testing before being welded to the web.

**3.9.6 Cross frames.** Cross frame welds which are on opposite sides of a common plane of contact shall not be wrapped but terminated 1/4 in (6 mm) short of the common corner.

### 3.10 Heat Curving, Cambering, and Straightening.

**3.10.1** Straightening rolled or bent material, cambering, and heat curving rolled beams and welded girders shall conform to the requirements of AASHTO 11.4.7 and 11.4.12.2, respectively.

#### 3.10.2 Temperature.

**3.10.2.1** When heating is permitted, the maximum allowable temperature of the steel shall be 1,200 °F (650 °C) (a dull red) for AASHTO M 270/M 270M (ASTM A 709/A 709M) steels with a specified minimum yield point equal to or less than 50 ksi, e.g. Gr 36, 50, and 50W (345 MPa, e.g. Gr 250, 345, and 345W). When the application of heat to AASHTO M 270/M 270M Grade 485W and 70W and 100/100W (690/690W) steels is permitted by the Engineer, the temperature shall not exceed 1,050 °F (570 °C) nor shall the temperature exceed 900 °F (480 °C) at weld metal or within 6 in (150 mm) of weld metal, nor shall the heat be applied directly to weld metal.

**3.10.2.2** Heating temperatures shall be controlled with temperature indicating crayons. The fabricator shall provide temperature indicating crayons manufactured for 600°, 1,000°, 1,100° and 1,250 °F (315°, 540°, 600°, and 675 °C). Heat measurements shall be made after the heating flame has been removed from the steel.

**3.10.3 Artificial cooling.** Quenching with water or water and air will not be permitted. Cooling with dry compressed air will be permitted after the steel has cooled to 600 °F (315 °C).

**3.10.4 Destructive heating.** Any heating procedure which causes a portion of the steel to be heated to a temperature greater than 1,250 °F (675 °C) shall be considered destructive heating. Destructive heating shall automatically cause the rejection of the steel. Steel rejected for destructive heating shall be investigated for reacceptance, repair, or replacement by tests ordered by the Department.

**3.10.5 Damage.** Any method of handling, supporting, or loading that causes the member to distort permanently (yield without the application of heat) will result in rejection of the member. All nondestructive tests to evaluate damage and any corrective work ordered by the Department to compensate for overstressing shall be performed by the fabricator.

**3.10.6 Sequence of operations for heat curving.** Members shall be heat curved prior to performing the following work, unless otherwise approved by the Department.

- (a) Attachment of lateral gusset plates.
- (b) Attachment of longitudinal stiffeners.
- (c) Welding of intermediate stiffeners and connection plates to the flanges.

### **3.10.7 Heating patterns.**

**3.10.7.1** Heating patterns shall be marked on the flange surfaces prior to heating.

**3.10.7.2** Heating shall be conducted to bring the steel within the planned pattern to a temperature between 900° and 1,150 °F (480° and 625 °C) as rapidly as possible without overheating the steel.

**3.10.7.3** The heating torches shall be manipulated to guard against general and surface overheating. When heating thick plates, it may be necessary to occasionally interrupt heating for periods of less than one minute to allow the heat to soak into the flange and avoid surface overheating.

**3.10.8 Verification of camber and sweep.** After fabrication of rolled beams and welded girders is complete, the fabricator shall measure the camber in the unloaded position (with the web horizontal) and, if applicable, the sweep (with the web vertical) at the 1/4 points as a minimum. The fabricator shall furnish a report to the Department listing the camber and sweep measurements and certify that they are within specified tolerances.

## **3.11 Connections Using High Strength Bolts.**

### **3.11.1 General.**

**3.11.1.1** Structural joints shall be assembled using AASHTO M 164, ASTM A 325 (AASHTO M 164M, ASTM A 325M) high strength bolts tightened to a high tension.

**3.11.1.2** Bolts, nuts, washers and direct tension indicators (DTIs) shall conform to the requirements of 2.4.

## SECTION 550

**3.11.1.3** Standard holes (1/16 in larger than diameter of bolt) shall be used in high strength bolted connections. Proposed use of oversize or slotted holes shall be subject to approval by the Administrator, Bureau of Bridge Design. (See Table 5.)

**Table 5E - Nominal Hole Dimensions (English)**

	Hole Dimensions, inches			
	Standard (Dia.)	Oversize (Dia.)	Short Slot (Width x Length)	Long Slot (Width x Length)
1/2	9/16	5/8	9/16 x 11/16	9/16 x 1-1/4
5/8	11/16	13/16	11/16 x 7/8	11/16 x 1-9/16
3/4	13/16	15/16	13/16 x 1	13/16 x 1-7/8
7/8	15/16	1-1/16	15/16 x 1-1/8	15/16 x 2-3/16
1	1-1/16	1-1/4	1-1/16 x 1-5/16	1-1/16 x 2-1/2
>1-1/8	d + 1/16	d+ 5/16	(d +1/16) x (d+ 3/8)	(d+ 1/16) x (2.5 x d)

**Table 5 - Nominal Hole Dimensions (Metric)**

	Hole Dimensions, mm			
	Standard (Dia.)	Oversize (Dia.)	Short Slot (Width by Length)	Long Slot (Width by Length)
M16	18	20	18 by 22	18 by 40
M20	22	24	22 by 26	22 by 50
M22	24	28	24 by 30	24 by 55
M24	27	30	27 by 32	27 by 60
M27	30	35	30 by 37	30 by 67
M30	33	38	33 by 40	33 by 75
M36	39	44	39 by 46	39 by 90

**3.11.1.4** The assembly of structural joints with high strength bolts shall conform to the requirements of AASHTO 11.5.6. Installation and tightening of high strength bolts shall be in accordance with AASHTO 11.5.6.4. Of particular importance is obtaining the snug tight condition (as defined in 3.11.6.4.2) before final tightening.

**3.11.1.5** All bolted connections are classified as slip critical, unless noted otherwise on the plans.

**3.11.1.6** Bolts shall be tightened to the required pretension by the direct tension indicator (DTI) method according to the procedures and requirements of 3.11.6.7. At the written request of the Contractor and with approval of the Engineer, bolts may be tensioned to the required tension by the turn-of-nut method according to 3.11.6.4 or the calibrated-wrench method, provided the procedures required in 3.11.6.5 are carefully and thoroughly followed.

**3.11.1.7** A Skidmore-Wilhelm Calibrator or an acceptable equivalent tension measuring device shall be required at each job site during bolt installation. Periodic testing (at least once each working day) shall be performed to assure compliance with the installation test procedures required herein. Bolts that are too short for the Skidmore-Wilhelm Calibrator may be tested using direct tension indicators (DTIs). The DTIs must be calibrated in the Skidmore-Wilhelm Calibrator using longer bolts.

**3.11.1.8** The rotational-capacity test described in 2.4 shall be performed on each rotational-capacity lot prior to the start of bolt installation.

**3.11.1.9** Bolt, nut and washer combinations as installed shall be taken from the same rotational-capacity lot.

**3.11.1.10** The Contractor shall supply a sufficient number of extra bolts, nuts, washers and DTIs for testing as may be required and described herein.

**3.11.1.11** Direct Tension Indicators shall conform to ASTM F 959, AASHTO 11.5.6.4.7.

**3.11.1.12** Spline end (twist-off) bolts and lock-pin and collar fasteners shall not be used.

### **3.11.2 Bolt Holes.**

**3.11.2.1** Holes for high strength bolts shall conform to the requirements of AASHTO 11.4.8.

**3.11.2.2 Primary members.** All holes in components of main members shall be subpunched and reamed, subdrilled and reamed, or drilled from the solid.

**3.11.2.3 Secondary members.** Holes in secondary members, including cross frames, diaphragms, and lateral bracing, may be punched full size when the thickness of the steel does not exceed the limits specified in AASHTO 11.4.8.1.1 [namely, 3/4 in (20 mm) thick for structural carbon steel and 5/8 in (16 mm) for high-strength steel].

**3.11.2.4 Lateral bracing.** Oversize holes (see Table 5) may be used for lateral bracing with the following provisions:

- (a) Oversize holes occur in only one component of the bolted connection.
- (b) The holes in the girder stiffener/connection plate are made standard size.
- (c) The locations of the oversize holes are indicated on the shop fabrication drawings.
- (d) The exposed oversize holes are covered with a hardened ASTM F436 (ASTM F 436M) washer.

**3.11.2.5 Field reaming.** The field reaming of bolt holes is not permitted without approval of the Administrator, Bureau of Bridge Design, and shall conform to the requirements of 3.15.7.

**3.11.2.6 Welded restoration of material with misplaced holes.** The restoration by welding of material with misplaced holes shall be approved by the Engineer and shall be performed in accordance with 3.6.9 and the AASHTO Welding Specifications (section 3.7.7). Soundness of the restored base metal shall be verified by radiographic testing. For main members in tension, the weld repair shall be postheated at 200°F (95 °C) for one hour per 1 in (25 mm) of plate thickness, and weld soundness shall be verified by ultrasonic or radiographic testing.

**3.11.3** Preassembly of bolted connections. Preassembly shall conform to the requirements of AASHTO 11.5.3.

**3.11.4 Match-marking.** Connecting parts assembled in the shop for the purpose of reaming or drilling holes in field connections shall be match-marked. A diagram showing the match marks shall be furnished to the Engineer, unless the connecting parts are shipped attached to the piece.

### **3.11.5 Bolted Parts.**

**3.11.5.1** All material within the grip of the bolt shall be steel. There shall be no compressible material such as gaskets or insulation within the grip. Bolted steel parts shall fit solidly together after the

## SECTION 550

bolts are tightened. The slope of the surfaces of parts in contact with the bolt head or nut shall not exceed 1:20 with respect to a plane normal to the bolt axis.

**3.11.5.2** Prior to assembly, all joint surfaces, including surfaces adjacent to the bolt heads, nuts or washers shall be free of scale, and shall also be free of burrs, dirt, other foreign material, and other defects that would prevent solid seating of the connected parts in the snug tight condition.

**3.11.5.3** Contact surfaces within slip critical connections shall be free of oil, paint, lacquer, rust inhibitor, and galvanizing. Paint, including any inadvertent overspray, shall be excluded from areas closer than 1 in (25 mm) from the edge of any hole and all areas within the bolt pattern, including under the bolt head and nut. Paint may be permitted on contact surfaces of slip critical joints, if approved by the Engineer, when the paint has been tested and the joints have been designed in accordance with AASHTO Article 10.32.3.2.3, Div. I.

**3.11.5.4** The length of bolts shall be such that the end of the bolt will be flush with or up to three threads outside the face of the nut when properly installed.

### **3.11.6 Installation and Tightening.**

#### **3.11.6.1 Handling and Storage of Fasteners.**

**3.11.6.1.1** Fasteners (i.e. threaded bolts and nuts), washers, and DTI's shall be protected from dirt and moisture at the job site and stored in a building, shed or trailer. Only as many fasteners as are anticipated to be installed and tightened during a work shift shall be taken from protected storage. Fasteners not used shall be returned to protected storage at the end of the shift. Storage in a shipping container covered with plastic sheeting is not acceptable.

**3.11.6.1.2** Fasteners shall not be cleaned of lubricant that is present in the as-delivered condition. Fasteners must be "oily" to the touch when installed. Galvanized nuts shall be checked to verify that a visible lubricant is on the threads. Lubricant shall be removed after bolt installation prior to painting.

**3.11.6.1.3** Weathered or rusted fasteners resulting from job site conditions shall be rejected. The Contractor may submit for approval a procedure for cleaning and relubricating rejected fasteners. Recleaned or relubricated bolt, nut and washer assemblies shall be retested in accordance with 3.11.1.8 prior to installation. Relubrication after cleaning may be accomplished with an approved stick wax applied to the bolt threads and to the nut face in contact with the washer.

#### **3.11.6.2 Bolt Tension.**

**3.11.6.2.1** Fasteners (i.e. threaded bolts and nuts) together with washers of size and quality specified shall be installed in properly aligned holes and tensioned by the Direct Tension Indicator (DTI) method (or at the written request of the Contractor and with approval of the Engineer, the turn-of-nut method or calibrated-wrench method) to not less than the minimum tension specified in Table 6 when all the fasteners are tight. Bolts shall be tightened by turning the nut while the bolt is prevented from rotating. Tightening may be done by turning the bolt while the nut is prevented from rotating when it is impractical to turn the nut. Impact wrenches, if used, shall be of adequate capacity and sufficiently supplied with air to perform the required tightening of each bolt in approximately 10 seconds.

**Table 6E - Required Fastener Tension (English)**

Nominal Bolt Size, inches	Minimum Bolt Installation Tension <sup>1</sup> in 1000's of pounds (kips)	5 % Greater Than Min. Bolt Tension <sup>2</sup> in kips
	A 325 Bolts	A 325 Bolts
1/2	12	12.6
5/8	19	20.0
3/4	28	29.4
7/8	39	41.0
1	51	53.6
1-1/8	56	58.8
1-1/4	71	74.6
1-3/8	85	89.3
1-1/2	103	108.2

<sup>1</sup> Equal to 70 percent of specified minimum tensile strength of bolts rounded to the nearest kip.

<sup>2</sup> Equal to 5 percent greater than minimum bolt installation tension rounded to the nearest 0.5 kip.

**Table 6 - Required Fastener Tension (Metric)**

Bolt Size	Minimum Bolt Installation Tension <sup>1</sup> kN	5 % Greater Than Min. Bolt Tension <sup>2</sup> kN
	A 325M Bolts	A 325M Bolts
M16	91	95.5
M20	142	149.0
M22	176	185.0
M24	205	215.5
M27	267	280.5
M30	326	342.5
M36	475	499.0

<sup>1</sup> Equal to 70 percent of specified minimum tensile strength of bolts rounded to the nearest kN.

<sup>2</sup> Equal to 5 percent greater than minimum bolt installation tension rounded to the nearest 0.5 kN.

**3.11.6.2.2 Washers.** All bolts shall have a hardened washer under the element (nut or bolt head) turned in tightening. Where an outer face of the bolted parts has a slope of more than 1:20 with respect to a plane normal to the bolt axis, a smooth beveled washer shall be used to compensate for the lack of parallelism.

### 3.11.6.3 Tension Calibrator.

**3.11.6.3.1** A Skidmore-Wilhelm calibrator, or other acceptable device capable of indicating actual bolt tension, shall be supplied by the Contractor and shall be required at all job sites where high strength bolts in slip-critical connections are being installed and tightened.

## SECTION 550

**3.11.6.3.2** The bolt tension indicating device shall be used to confirm (1) the suitability of the complete fastener assembly, including lubrication and thread condition, to be used in the work to satisfy the requirements of Table 6, (2) the calibration of the wrenches, if applicable, and (3) the understanding and proper use by the bolting crew of the method to be used.

**3.11.6.3.3** Confirmation tests shall be performed as specified in 3.11.6.4, 3.11.6.5 and 3.11.6.7, as applicable, to ensure that the as-installed bolt/nut/washer assembly meets installation requirements. The Engineer may require the recalibration of any wrench at any time.

**3.11.6.3.4** The Contractor shall deliver the bolt tension indicating device to the Department's Laboratory before its use in the work to confirm its accuracy through calibration.

**3.11.6.3.5** Bolt/nut/washer assemblies used in calibration and confirmation tests shall not be used in the work. A sufficient number of bolt assemblies shall be supplied for testing.

**3.11.6.3.6** Calibration and confirmation testing shall use bolts with the same condition as those in the work at the time of final tightening. If final tightening is to occur after the bolted connection has been exposed to weather for a period of time, then bolts from the work shall be removed for testing.

### **3.11.6.4 Turn-of-Nut Tightening.**

**3.11.6.4.1 Testing.** A representative sample of not less than three bolt/nut/washer assemblies of each diameter, length and grade to be used in the work shall be checked at the start of each day's work in a device capable of indicating bolt tension. The test shall demonstrate that the method for estimating the snug-tight condition and controlling the turns from snug tight to be used by the bolting crew develops a tension not less than five percent greater than the minimum tension required by Table 6.

**3.11.6.4.2 Snug tightening.** Bolts shall be installed in all holes of the connection and brought to a snug-tight condition. (If the joint is not properly "snugged", the tightening procedure will not work.) Snug tight is defined as the tightness that exists when the plies of the joint are in firm contact. This may be attained by a few impacts of an impact wrench or the full effort of a man using an ordinary spud wrench. Snug tightening shall progress systematically from the most rigid part of the connection to the free edges, and then the bolts of the connection shall be retightened in a similar systematic manner as necessary until all bolts are simultaneously snug tight and the connection is fully compacted.

**3.11.6.4.3 Tightening.** Following this initial snug tightening operation, all bolts in the connection shall be tightened further by the applicable amount of rotation specified in Table 7. During the tightening operation there shall be no rotation of the part not turned by the wrench. Tightening shall progress systematically from the most rigid part of the joint to its free edges.

### **3.11.6.5 Calibrated-Wrench Tightening.**

**3.11.6.5.1** The calibrated wrench method includes the use of manual torque wrenches which indicates torque by means of a dial and power wrenches which are adjusted to stall at a specified tension. Calibrated-wrench tightening may be used only when installation procedures are calibrated on a daily basis and when a hardened washer is used under the element turned in tightening. This specification does not recognize standard torques determined from tables or from formulas which are assumed to relate torque to tension. Installation torque must be determined directly from calibrations performed at the job site reflecting actual work conditions.

**3.11.6.5.2 Calibration.** When calibrated wrenches are used for installation, they shall be set to provide a tension not less than five percent in excess of the minimum tension specified in Table 6. The installation procedures shall be calibrated by verification testing at least once each working day for each

diameter, length and grade of bolt, using bolt/nut/washer assemblies that are being installed in the work. This verification testing shall be accomplished in a device capable of indicating actual bolt tension by tightening three typical bolts of each diameter, length and grade from the bolts being installed and with a hardened washer from the washers being used in the work under the element turned in tightening. Wrenches shall be recalibrated when a significant difference is noted in the surface condition of the bolts, threads, nuts, or washers.

**3.11.6.5.3 Snug tightening.** When calibrated wrenches are used to install and tension bolts in a connection, bolts shall be installed with hardened washers under the element turned in tightening bolts in all holes of the connection and brought to a snug-tight condition (see 3.11.6.4.2).

**3.11.6.5.4 Tightening.** Following the initial snug tightening operation, all bolts in the connection shall be tightened using the calibrated wrench to the minimum bolt installation tension in Table 6. (Power wrenches shall be adjusted to stall or cut out at the required tension. Manual torque wrenches shall tighten the fastener to the torque value corresponding to the calibrated tension.) Tightening shall progress systematically from the most rigid part of the joint to its free edges. The wrench shall be returned to “touch up” previously tightened bolts which may have been relaxed as a result of the subsequent tightening of adjacent bolts until all bolts are tightened to the prescribed amount. If manual torque wrenches are used, nuts shall be turned in the tightening direction when torque value is measured.

**3.11.6.5.5 Verification.** Wrench adjustment shall be verified during actual installation in the assembled steelwork so that the wrench adjustment selected by the calibration does not produce a nut or bolt head rotation from snug tight greater than that permitted in Table 7.

**3.11.6.6 Reuse of bolts.** ASTM A 325 (ASTM A 325M) bolts shall not be reused after having been tightened to the required fastener tension, Table 6. Touching up or retightening previously tightened bolts which may have been loosened by the tightening of adjacent bolts shall not be considered as reuse provided the snugging up continues from the initial position and does not require greater rotation, including the tolerance, than that required by Table 7. ASTM A 490 (ASTM A 490M) bolts shall not be reused.

**Table 7 - Nut Rotation from Snug Tight Condition<sup>1,2</sup>**

Bolt Length <sup>4,5</sup>	Disposition of Outer Face of Bolted Parts		
	BOTH FACES NORMAL to bolt axis	ONE FACE NORMAL to bolt axis and OTHER SLOPED not more than 1:20 (beveled washer not used)	BOTH FACES SLOPED not more than 1:20 from normal to the bolt axis (beveled washer not used)
Up to and including 4D (3.5 in [88 mm])	1/3 turn	1/2 turn	2/3 turn
Over 4D to 8D (7 in [176 mm])	1/2 turn	2/3 turn	5/6 turn
Over 8D to 12D <sup>3</sup> (10.5 in [264 mm])	2/3 turn	5/6 turn	1 turn

<sup>1</sup> Nut rotation is relative to bolt regardless of the element (nut or bolt) being turned. For bolts installed by 1/2 turn (180 degrees) and less, the tolerance should be plus or minus 30 degrees; for bolts installed by 2/3 turn (240 degrees) and more, the tolerance should be plus or minus 45 degrees.

<sup>2</sup> Applicable only to connections in which all material within the grip of the bolt is steel.

## SECTION 550

<sup>3</sup> No research has been performed by the Council to establish the turn-of-nut procedure for bolt lengths exceeding 12 diameters. Therefore, the required rotation must be determined by actual test in a suitable tension measuring device which simulates conditions of solidly fitted steel.

<sup>4</sup> Bolt length is measured from underside of head to extreme end of bolt.

<sup>5</sup> Bolt lengths in parenthesis ( ) are for an 7/8 in diameter (M22) bolt.

D = nominal bolt diameter (inches)

### 3.11.6.7 Direct Tension Indicator Tensioning.

**3.11.6.7.1 General.** These specifications are written to conform to Procedure for Verification and Installation of High Strength Bolts with Direct Tension Indicators (DTIs) in Appendix A6 of FHWA Report SA-91-031, revised April 1992, and AASHTO Standard Specifications for Highway Bridges, 1996, except as noted. DTIs installed with high strength bolts to indicate bolt tension shall be subjected to field verification testing (3.11.6.7.2) prior to installation, and the installation requirements (3.11.6.7.3) described below.

**3.11.6.7.1.1** When Direct Tension Indicators (DTI's) are to be installed with high-strength bolts to indicate bolt tension, the DTI shall be placed under the head of the bolt with the protrusions facing the head of the bolt, and the nut shall be turned to tension the fastener with a hardened washer under it. If for reasons of installation or inspection accessibility it is necessary to place the DTI under the turned element, the DTI shall be oriented so that the protrusions face outward from the work, and a hardened washer shall be placed between the DTI and the turned element.

**3.11.6.7.1.2** The bolt, DTI, hardened washer, and nut assembly used in the verification testing device and installed in the work shall be such that at least 3 and preferably not more than 5 threads are located in the grip (i.e. between the bearing face of the nut and the bolt head).

**3.11.6.7.1.3** Bolts used in the verification test and installed in the work shall not be tightened to a "no-visible" gap condition (i.e. a condition when all the DTI protrusions are completely compressed). A visible gap must remain in at least one space after installation. [It is possible to have no entries and yet have a visible gap. The load in the bolt becomes indeterminate when no gap exists and may exceed the capacity of the fastener, possibly causing bolt failure by tensioning beyond complete crushing of the DTI.]

**3.11.6.7.1.4** The Contractor shall supply 5 mil tapered feeler gages, a calibrated bolt tension-measuring device, and equipment necessary to perform field verification testing and inspection of tensioned bolts. The feeler gages, fasteners, and impact and manual wrenches shall be the same as that to be used in the work.

**3.11.6.7.1.5** It is mandatory that the Contractor obtain the services of a qualified technical advisor employed by the DTI manufacturer to make at least one site visit to assist the Contractor and to assure the proper installation and use of DTI's, unless the Contractor can demonstrate to the Department's satisfaction successful use of DTI's on previous projects for the Department.

**3.11.6.7.2 Field verification testing.** Verification testing shall be performed in a calibrated bolt tension-measuring device (Skidmore) with a special flat insert (supplied by the Contractor) replacing the normal bolt head-holding insert. (This special insert allows the DTI to be located on the flat front face of the Skidmore for ease of observation and greater access to measure the DTI gap during testing).

**3.11.6.7.2.1** The purpose of verification testing is to ensure that (i) the DTI's were properly manufactured (since it is the performance of the DTI that controls the installed bolt tension) and that the fastener in the work will be at or above the required installation tension when the DTI has been compressed to allow entries for fewer than half the number of spaces; and (ii) the fastener in the work will not plastically deform when the DTI is compressed to the maximum allowable limit for the project.

**3.11.6.7.2.2** Three verification tests are required for each combination of fastener rotational-capacity lot, DTI lot, and DTI position (under the nut or bolt head) used on the project. All three tests must pass for the DTI and assembly combination to be approved. Testing shall be performed at the jobsite by the Contractor and witnessed by the Department.

**3.11.6.7.2.3** When testing for the normal DTI position, the nut shall be turned and the bolt head against the DTI shall be restrained from turning with another wrench. When testing with the DTI under the turned element, the turned element shall be placed on the flat front face of the Skidmore and the unturned element will be in the rear held by another wrench.

Table 8 - Direct Tension Indicators

Bolt Size (inch)	Verification Tension <sup>1</sup> (kips)		Verification - Required Number of Entries <sup>2,3</sup>		Number of DTI Spaces between Protrusions		Installation - Required Number of Entries <sup>2,4</sup>	
	A325	A490	A325	A490	A325	A490	A325	A490
1/2	13	16	3-4	3-5	4	5	0-2	0-2
5/8	20	25	3-4	3-5	4	5	0-2	0-2
3/4	29	37	3-5	4-6	5	6	0-2	0-3
7/8	41	51	3-5	4-6	5	6	0-2	0-3
1	54	67	4-6	4-7	6	7	0-3	0-3
1-1/8	59	84	4-6	4-7	6	7	0-3	0-3
1-1/4	75	107	4-7	5-8	7	8	0-4	0-4
1-3/8	89	127	4-7	5-8	7	8	0-4	0-4
1-1/2	108	155	5-8	5-9	8	9	0-4	0-4

<sup>1</sup> Verification tension is 1.05 x the required Table 6 installation tension.

<sup>2</sup> An entry occurs when a 5 mil tapered feeler gage fits into the space between DTI protrusions and touches the bolt shank. See 3.11.6.7.1.3.

<sup>3</sup> For coated DTI's under the turned element at least one entry is required.

<sup>4</sup> For coated DTI's under the turned element no entries are allowed.

**3.11.6.7.2.4** The verification test shall be conducted in two stages:

- a) **Stage 1.** The fastener shall first be tensioned to the Verification Tension load listed in Table 8 for the grade and size of fastener. If an impact wrench is used, tension to a load two-thirds below the required load and use a manual wrench to attain the required tension. (The load-indicating needle of the bolt calibrator cannot be read accurately when an impact wrench is used, due to vibrations).
- b) Determine and record the number of entries of a 5 mil feeler gage in the spaces between the protrusions (the number of spaces on a DTI is listed in column 4 of Table 8). The number of entries shall meet the number listed in column 3 of Table 8 under Verification - Required Number

## SECTION 550

of Entries for the grade and size of bolt for DTI's. [When using coated (galvanized or epoxy coated) DTI's under the turned element there shall be at least one entry of the feeler gage.] The DTI lot is rejected if the number of entries is less than the value in column 3 of the table or if for coated DTI's used under the turned element there are no entries.

- c) **Stage 2.** After the number of entries is recorded at the verification load, the fastener shall be further tensioned with a manual wrench until there are no entries for the 5-mil feeler gage but a visible gap exists in at least one space. Note and record the load in the bolt at this condition (the maximum allowable limit of DTI compression) and remove the fastener from the tension-measuring device.
- d) The capability of the bolt to tolerate the maximum allowable limit of DTI compression is determined in two ways. (i) The simplest is to hand turn the nut down the complete thread length of the bolt excluding thread runout. If this is successful, then the bolt has not undergone significant plastic deformation and the assembly passes the verification test. (ii) If the nut cannot be turned down the complete thread length, the DTI lot shall be rejected unless the load recorded is less than 95% of the average load measured in the rotational capacity test of the fastener lot as specified in Article 11.5.6.4.2g of the AASHTO Standard Specifications for Highway Bridges, Division II, in which case the assembly is deemed to have passed the test.

**3.11.6.7.2.5** Bolts used in verification tests shall be marked and shall not be reused in the work.

**3.11.6.7.2.6 Short bolts.** If the bolt is too short to be tested in the calibration device, the DTI shall be tested on a longer bolt in a calibrator to determine the number of entries at the Verification Tension listed in column 2 of Table 8. The number of entries shall meet the number listed in column 3 of Table 8 under Verification - Required Number of Entries. Another DTI from the same lot shall then be assembled with the short bolt in a convenient hole in the work. The fastener assembly shall be tensioned with a manual wrench until there are no entries for the 5-mil feeler gage but a visible gap exists in at least one space. The fastener shall then be disassembled. Subsequently the nut must be run down, by hand, for the complete thread length of the bolt excluding thread runout. The DTI lot shall be rejected if the nut cannot be assembled to this thread length. Three verification tests are required as stated above.

**3.11.6.7.3 Installation and Inspection.** Installation of fasteners using DTI's shall be performed in two stages, initial (joint snugging) and final (bolt tensioning). For normal installation, the bolt head against the DTI shall be held against rotation during each stage of the installation while the nut is turned. Two workers are required, one to operate the wrench, and the other to prevent turning of the element against the DTI and to monitor the gap.

- a) **Stage 1. Joint snugging.** The connection shall first be snugged with bolts installed in all the holes of the connection and the bolts initially tensioned sufficiently to bring all the plies of the connection into firm contact while the drift pins remain in the connection. Snugging shall progress systematically beginning at the most rigid part of the connection and progressing to the free edges until the connection is fully compacted, as described in 3.11.6.4.2.
- b) DTI's shall be inspected after snugging and the gaps checked. The number of entries for a 5-mil feeler gage in the DTI after snugging shall meet the number listed in column 3 of Table 8 under Verification - Required Number of Entries. If the number of entries is less than the values in the table, the fastener must be removed and another DTI installed, followed by resnugging of the fastener. [This is required because a fastener's tension may have relaxed during the snugging of adjacent fasteners. A compressed DTI does not rebound if the fastener tension is reduced. If a DTI were left in place, which has fewer entries, it would give a false indication of bolt tension.]

- c) **Stage 2. Final bolt tensioning.** The bolts in the connection shall then be further tensioned to the point that the number of entries for a 5-mil feeler gage meets the number listed in Table 8 under Installation - Required Number of Entries. Tightening shall progress systematically beginning at the most rigid part of the connection and progressing to the free edges. Drift pins shall be removed during this process. Several cycles may be required. If the fastener is tightened so that no visible gap in any space remains, the bolt and DTI shall be removed, and replaced by a new properly tightened fastener and DTI.
- d) An additional required inspection step is to check the bolt thread stickout on the nut side after installation to the final specified gap to look for inconsistency of pattern. Any stickouts greater than the other bolts shall be investigated and discarded (e.g. if necking down of the bolt has occurred or the wrong length bolt was used). The end of the properly installed bolt shall be at least flush with the nut or stick out not more than three threads.

**3.11.7.1 Inspection responsibility.** Before the installation of fasteners in the work, the Engineer shall check the marking, surface condition and storage of bolts, nuts and washers and the faying (contact) surfaces of joints for compliance with the above requirements. The Engineer shall observe calibration or testing procedures or both required above as applicable, to confirm that the selected procedure is properly used and that, when so used with the fastener assemblies supplied the tensions specified in Table 6 are provided. The Engineer shall monitor the installation of fasteners in the work to assure that the selected procedure, as demonstrated in the initial testing to provide the specified tension, is routinely properly applied.

**3.11.7.2 Inspection of completed joints.** In addition to the requirements of 3.11.7.1, inspection of completed joints is required according to the following inspection procedure.

**3.11.7.2.1 Bolt tension for fasteners with DTIs shall be verified by the use of a manual inspection torque wrench (which indicates torque by means of a dial) or by using 5 mil tapered feeler gages provided and operated by the Contractor.**

**3.11.7.2.2 Calibration of inspecting wrench.** At least once each inspection day, a representative sample of three bolts of each diameter, length and grade of bolt used in the work shall be tightened in the tension measuring device by any convenient means to an initial (i.e. snug-tight) condition equal to approximately 15 percent of the required fastener tension and then to the minimum tension specified in Table 6. There shall be a washer under the part turned in tightening each bolt. Tightening beyond the initial condition must not produce greater nut rotation than 1-1/2 times that permitted in Table 7. The job-inspecting torque shall be taken as the average of the torque required for all three bolts. The inspecting wrench shall then be applied to the tightened bolts in the work and the torque necessary to turn the nut or head 5 degrees (approximately 1 in [25 mm] at 12 in [300 mm] radius) in the tightening direction shall be determined.

**3.11.7.2.3 Inspection of turn-of-nut or calibrated-wrench tightened bolts.** Bolts represented by the sample in the foregoing paragraph which have been tightened in the structure shall be inspected by applying, in the tightening direction, the inspecting wrench and its job torque to 10 percent of the bolts, but not less than 2 bolts, selected at random in each connection in question. If no nut or bolt head is turned by application of the job inspecting torque, the connection shall be accepted as properly tightened. If any nut or bolt is turned by the application of the job inspecting torque, all bolts in the connections shall be tested, and all bolts whose nut or head is turned by the job inspecting torque shall be tightened and reinspected. Alternatively, it is the fabricator or erector's option to retighten all of the bolts in the connection and then resubmit the connection for the specified inspection.

## SECTION 550

**3.11.7.2.4 Inspection of DTI tensioned bolts.** All bolts installed using DTI's shall be inspected after snug tightening and again after full tensioning with 100% visual inspection and 10% of the bolts in any connection (but not less than two) shall be inspected by feeler gage. If the installation of inspected bolts is accepted, then the connection shall be accepted as properly tensioned. If any bolt in a connection does not pass inspection, then all (100%) of the bolts in that connection shall be inspected with the feeler gage. Any bolt, which does not pass inspection, as described herein shall be further tensioned, if required, or if over tensioned, shall be removed and replaced by a new properly tensioned bolt and DTI.

**3.11.7.2.5** This specification does not recognize standard torques determined from tables or from formulas which are assumed to relate torque to tension. Testing using such standard torques shall not be considered valid. Inspection torques must be determined directly from calibrations performed at the job site reflecting actual work conditions.

**3.11.7.3 Delayed verification inspection.** The procedure specified in 3.11.7.2 is intended for inspection of bolted connections and verification of pretension within 24 hours of tensioning the joint. If verification of bolt tension is required after a passage of a period of time and exposure of the completed joints, the procedures of 3.11.7.2 will provide an indication of bolt tension that is of questionable accuracy. Procedures appropriate to the specific situation should be used for verification of bolt tension. This might involve use of the inspection procedure contained in 3.11.7.2, or might require the development and use of alternate procedures.

### **3.12 Surface Preparation.**

#### **3.12.1 General Requirements.**

**3.12.1.1 Scope.** All structural steel included in 550 shall be blast cleaned.

**3.12.1.2 Preblast.** Structural steel shall be blast cleaned prior to fabrication except as permitted in 3.12.3.

**3.12.1.3 Blast cleaning.** Blast cleaning shall be performed in conformance with the requirements of SSPC-SP 10, Near-White Blast Cleaning, unless otherwise directed.

**3.12.1.4 Method.** Blast cleaning shall be performed by either the centrifugal wheel or the air pressure blast method, unless permission is given to use other methods.

**3.12.2 Material condition.** Upon inspection of the cleaned steel, evidence of rolled-in scale or slag, pits, other surface imperfections, or laminations may indicate that certain material is unacceptable in accordance with AASHTO M 160/M 160M (ASTM A 6/A 6M). The disposition of such unacceptable material shall be governed by 106.09. The welded repair of discontinuities shall be performed in conformance with the requirements of the AASHTO Welding Specifications and with 3.6.9. Welded repairs of main members in tension shall also be inspected by radiographic testing.

**3.12.3 Preparation for welding.** Mill scale shall be removed by blast cleaning from all structural steel surfaces to be welded. At the fabricator's option all mill scale may be removed from the faying (contact) surfaces by first grinding them to bare metal (e.g. girder flange-to-web and stiffener-to-web welds) before blast cleaning the rest of the steel. However, grinding is at the fabricator's own risk if subsequent blast cleaning reveals material conditions that are unacceptable.

#### **3.12.4 Unpainted Weathering Steel.**

**3.12.4.1 Initial cleaning.** High strength low alloy structural weathering steel shall be blast cleaned before fabrication to remove all mill scale or other foreign material in order to allow uniform

oxidation to occur when exposed to the atmosphere. It will be necessary to remove all heavy coatings of oil or grease with suitable solvent prior to blast cleaning operations.

**3.12.4.2 Cleaning after fabrication.** Care shall be taken to keep weathering steel clean of all foreign matter such as grease, oil, chalk marks, crayon marks, and dirt during and after fabrication.. Slag, flux, and spatter resulting from welding operations shall be removed. Identification markings on surfaces to be exposed to view in finished structures will not be permitted. Natural oxidation of the steel will not be considered foreign matter. Steel which becomes contaminated by foreign matter after it has been blast cleaned shall be cleaned as soon as possible with the proper solvent according to the requirements of SSPC-SP 1, Solvent Cleaning, or SSPC-SP 2, Hand Tool Cleaning, or SSPC-SP 3, Power Tool Cleaning, or SSPC-SP 10, Near-White Blast Cleaning depending upon the severity of the surface condition. Fascia girders will require cleaning by SSPC-SP 10, Near-White Blast Cleaning, if the above methods are not able to produce a uniform, acceptable surface on the fascia surfaces.

**3.12.4.3 Store to weather.** The cleaned high strength low alloy weathering steel shall be stored in a position and at a location allowing optimum weathering of the surfaces of the steel which will be exposed to public view. Water shall not be allowed to collect in puddles on such surfaces. The duration of exposure to the weather shall be as long as practicable prior to erection.

### **3.12.5 Painted Steel.**

**3.12.5.1** Shop painting shall conform to the requirements of AASHTO 13 and SSPC-PA 1 and Section 550-Special Provision for painting, whichever is more stringent.

**3.12.5.2** Structural steel conforming to AASHTO M 270/M 270M Gr 36 or 50 (Gr 250 or 345) shall be painted, unless noted otherwise on the plans.

**3.12.5.3** Structural steel conforming to M 270/M 270M 50W (weathering) (Gr 345W [weathering]) shall not be painted, unless otherwise noted on the plans.

**3.12.5.4** Surfaces to be painted shall include bridge shoes (except sliding surfaces). Surfaces in direct contact with concrete shall be painted with primer only.

**3.12.5.5 Expansion joint.** When an expansion joint is included as part of the structural steel, it shall be painted with one shop coat of approved zinc-rich primer to a minimum dry film thickness of 3 mils (76  $\mu\text{m}$ ). Surfaces in direct contact with the seals shall be left unpainted. Surfaces in contact with concrete shall be primed only.

**3.12.5.6 Pier nose protection.** Pier nose protection steel (usually an angle) shall be galvanized in conformance with the requirements of AASHTO M 111 (ASTM A 123).

**3.12.5.7 Neutralizing welded surfaces.** Welded surfaces shall be neutralized by power wire brushing or blast cleaning prior to shop painting.

**3.12.5.8 Bearing protective coatings.** Machine finished surfaces in sliding contact, including surfaces in sockets at the top of rocker bearings, shall receive one coat of approved low temperature grease as soon as machining is complete. The Contractor shall maintain all protective coatings to prevent corrosion. All other machine finished surfaces shall be blasted and painted if painting of the structural steel is required.

## SECTION 550

### 3.13 Shop Painting.

#### 3.13.1 General.

**3.13.1.1** Shop painting shall conform to the requirements of AASHTO 13 and SSPC-PA 1 and the special provision, whichever is more stringent.

**3.13.1.2** Structural steel conforming to AASHTO M 270/M 270M Gr 36 or 50 (Gr 250 or 345) shall be painted, unless noted otherwise on the plans.

**3.13.1.3** Structural steel conforming to M 270/M 270M 50W (weathering) (Gr 345W [weathering]) shall not be painted, unless otherwise noted on the plans.

**3.13.1.4** Surfaces to be painted shall include bridge shoes (except sliding surfaces). Surfaces in direct contact with cast-place-concrete shall be painted with primer only.

**3.13.1.5** After paint has been applied, material shall not be handled until paint has thoroughly dried.

**3.13.1.6** See the special provision for paint sampling and testing requirements.

**3.13.2 Surface preparation.** Surface preparation for painting shall conform to the requirements of 3.12.5. If the steel surface after preblast and fabrication is not suitable for painting, it shall be blast cleaned again in accordance with SSPC-SP 10, Near-White Blast Cleaning.

#### 3.13.3 Paint System.

**3.13.3.1** When structural steel is required to be painted, the work shall conform to the painting requirements detailed in a special provision.

**3.13.4 Expansion joint.** When an expansion joint is included as part of the structural steel, it shall be painted with one shop coat of zinc-rich primer, 708-NH 1.60, to a minimum dry film thickness of 3 mils (76  $\mu\text{m}$ ). Surfaces in direct contact with the seals shall be left unpainted. Surfaces in contact with concrete shall be primed only.

**3.13.5 Pier nose protection.** Pier nose protection steel (usually an angle) shall be galvanized in conformance with the requirements of AASHTO M 111 (ASTM A 123).

### 3.14 Handling, Storing, and Shipping Material.

#### 3.14.1 General.

**3.14.1.1** Structural members shall be handled, stored and shipped in such a manner as to prevent damage to the material and to keep construction stresses within allowable values.

**3.14.1.2 Softeners.** Structural members shall be handled with suitable clamps or plate hooks which will not leave nicks, gouges, or depressions during handling. Chains shall not be used for handling structural members unless a protective shield (such as steel angles) is used between the chain and the steel.

**3.14.1.3** Girders and beams shall be handled, stored and shipped with their webs vertical and shall be adequately shored, braced, or clamped or braced and clamped to resist any lateral forces which might

occur. Members other than girders shall be handled, stored and shipped at all times so that the stronger axis is vertical to resist the dead load of the member.

**3.14.1.4** Permanent distortion resulting from improper handling or storage will be cause for rejection.

### **3.14.2 Handling.**

**3.14.2.1** Shallow nicks, gouges, or dog marks 1/8 in (3 mm ) deep or less on structural material caused by lifting devices shall be repaired by grinding to produce a smooth, flared surface with a minimum 1:10 slope in the longitudinal direction. On main members, this ground repair area shall be nondestructively tested by the magnetic particle or dye penetrant method.

**3.14.2.2** Nicks and gouges deeper than 1/8 in (3 mm) shall be repaired by filling with weld metal and grinding flush and smooth. The extent and method of repair of defects shall be consistent with the requirements for delivery of structural steel as specified in ASTM A 6/A 6M. Welded repairs shall use a preheat of 250 °F (120 °C) and shall be inspected by ultrasonic and dye penetrant testing.

**3.14.2.3** Damage deformations outside of usual tolerances shall be reported to the Engineer. Kinks shall result in rejection of the member.

**3.14.2.4 Lifting.** Proper consideration shall be given to guard against lateral buckling of long, unsupported beams and girders. As a general rule, straight beams and girders 30 in (760 mm) in depth or deeper lifted according to the following criteria should be stable. For the following L/b ratios, L equals the length of a portion of the girder as defined (in feet [meters]), and b equals the minimum width of the flange in compression (in feet [meters]).

(a) Case 1 (Overhang). The L/b ratio for the unsupported overhang length shall not exceed 35 nor shall the maximum overhang length exceed 50 ft (15 m). Two pickup points shall be required for all beams or girders with a total length exceeding 70 ft (21 m).

(b) Case 2 (Between pickup points). The L/b ratio for the unsupported distance between pickup points shall not exceed 85 nor shall the maximum distance exceed 100 ft (30 m).

**3.14.2.5** Field connection holes shall not be used for lifting the material or for tie-down.

**3.14.2.6** Coated steel shall be insulated from lifting devices and from the scraping and rubbing of parts that would damage the coating by the use of lifting softeners, padded slings, storage pallets, separators, cushioners, tie-downs, and other approved supports.

### **3.14.3 Storage.**

**3.14.3.1** Structural material and fabricated members shall be stored at the fabrication shop or construction site above the ground on platforms, skids, blocking or other supports and shall be protected as far as practicable from surface deterioration by exposure to conditions producing rust. Material shall be kept free from accumulations of dirt, oil, and foreign matter and shall be positioned to permit proper drainage. See 106.07.

**3.14.3.2** Horizontally curved fabricated girders in storage shall be secured in an acceptable manner to prevent overturning.

### **3.14.4 Shipping.**

**3.14.4.1** Marking and shipping shall conform to the requirements of AASHTO 11.4.15.

## SECTION 550

**3.14.4.2** Shipping bolts shall be removed and discarded at the construction site and not incorporated in the final assembled structure.

**3.14.4.3** Structural material shall be clean and free from deformities upon arrival on the project.

**3.14.4.4** Hold-down softeners shall be used to prevent chain marks on the structural material during shipment. Such softeners shall be durable enough to perform adequately.

**3.14.4.5** Structural members shall be shipped in the upright position (with the webs vertical), unless there are unusual circumstances and written permission from the Administrator, Bureau of Bridge Design is obtained to do otherwise.

**3.14.4.6** Structural members shipped on truck beds or supported on dollies shall not cantilever behind same in excess of 25 percent of their length. Other shipping configurations shall require calculations that demonstrate that the member will not be overstressed during shipment and submitted for documentation in accordance with 105.02. The calculations shall account for impact by adding 200% to the calculated actual stress. .

### **3.15 Erection of Structural Steel.**

#### **3.15.1 Delivery and Field Inspection.**

**3.15.1.1** Material, workmanship, and condition after shipment will be inspected after delivery to the construction site, with this and any previous inspections constituting only partial acceptance.

**3.15.1.2** All work of handling, assembling and erecting structural steel shall be subject to the inspection and approval of the Engineer, who shall be furnished with necessary facilities, including scaffolding and supports, to provide access to the structure to allow for inspection of workmanship and testing of field connections.

#### **3.15.2 Handling and Storage.**

**3.15.2.1** The provisions of 3.14 on handling and storage shall apply.

**3.15.2.2** No material shall, at any time, be dropped, thrown, dragged, or stored on the ground.

#### **3.15.3 Falsework, Scaffolding and Erection Plans.**

**3.15.3.1 Falsework and Scaffolding.** Falsework and scaffolding shall be properly designed and substantially constructed and maintained, without detrimental settlement or deformation, for the full loads that will come upon it. The Contractor shall prepare and submit plans for falsework and scaffolding for documentation in accordance with 105.02.

**3.15.3.2 Erection Plans.** Before starting the work of erecting all structures with welded girders or rolled beams, and prior to the erection of other structures when ordered, the Contractor shall submit an erection plan for documentation in accordance with 105.02. The erection plan shall describe the method of erection proposed and the amount and character of equipment proposed.

**3.15.3.3** The structural steel for the bridge may be used as supports for equipment and erection operations only when it is in its permanent position in the structure.

**3.15.4 Setting anchor rods.** Unless otherwise indicated on the plans, anchor rod holes having a diameter at least 1 in (25 mm) larger than that of the anchor bolts shall be drilled normal to the plane of

the bridge seat. Anchor rods shall be placed in the holes prior to final setting to assure proper fit. During freezing weather, the holes shall be kept free from ice in a satisfactory manner. Unless otherwise permitted, the final setting of anchor rods shall be made after all the structural steel has been erected.

**3.15.4.1** Anchor rods shall be set in one of the following materials:

- (a) Non-shrinking, non-ferrous, cement-base grout. This grout shall be used only when both the temperature of the masonry and the ambient temperature are kept at 40 °F (4 °C) or above until the grout has cured.
- (b) Fast-setting anchor cement.
- (c) Sulfur.

**3.15.4.2** Non-shrinking, non-ferrous, cement base grout or fast setting anchor cement shall be a product as included on the Qualified Products List. Unless otherwise directed, the recommendations of the manufacturer of the product shall be followed exactly, so as to completely fill the space around the bolt.

**3.15.4.3** Anchor rods in expansion shoes shall be located in relation to the slotted holes as required by the prevailing temperature. The nuts on anchor rods at the expansion ends of spans shall permit the free movement of the span.

### **3.15.5 Setting Bearings.**

**3.15.5.1** Bridge bearings shall be set level and must have full and uniform bearing on the substructure masonry. They shall not be placed on masonry bearing areas that are irregular or improperly cured or finished. Under no condition will the bearing area be acceptable at an elevation below that of the surrounding masonry.

**3.15.5.2** Unless otherwise indicated on the plans, bearing plates shall be placed on preformed fabric bearing pads meeting the requirements of 2.6. Each pad shall be the same size as the bearing plate it is to support. Holes for anchor rods shall be cleanly and accurately punched before setting the pad in place.

**3.15.5.3** Care shall be taken that full and free movement of the superstructure at the expansion bearings is not restricted by improper setting or adjustment of bearings or anchor rods and nuts.

**3.15.5.4** All protective grease applied in the shop to sliding bearing surfaces shall be removed immediately prior to erection of the superstructure. When the protective coating is removed, the parts shall be thoroughly cleaned and then recoated with the required grease (see 3.12.6) before erection of the superstructure.

**3.15.5.5** Shim plates, if required, shall be weathering steel or painted with shop-applied primer.

### **3.15.6 Assembling Steel.**

**3.15.6.1** Structural steel members shall be carefully handled during assembly so that no parts are bent, broken, or otherwise damaged. Slight defects may be repaired, if approved, and shall be corrected prior to erection. More severe damage and kinks will be cause for rejection of the damaged member. All repairs to structural steel shall be subject to approval by the Engineer.

**3.15.6.2** Structural steel shall not be erected before the bridge abutments have been backfilled to the elevation of the bridge seats, unless otherwise permitted. The final adjustment of bridge shoes shall be performed after approach slabs are constructed, unless otherwise permitted.

## SECTION 550

**3.15.6.3** The component parts of a structure shall be accurately assembled as shown on the plans and any match-marks shall be followed.

**3.15.6.4** Hammering which will injure or distort the members shall not be done.

**3.15.6.5** If surfaces which are to be connected by field bolting have been painted or contaminated with any foreign material or become moderately or heavily rusted that would make these connecting procedures unacceptable, the Contractor shall clean the surfaces of contaminants and loose rust at no additional cost to the Department. A tight coating of light rust will be permitted on faying (contact) surfaces of bolted joints.

**3.15.6.6** Fitting-up bolts shall be the required high strength bolts or bolts of the same nominal diameter as the high strength bolts. Cylindrical erection pins shall be 1/32 in (0.8 mm) larger.

**3.15.6.7** Curved girders and long span straight girders shall be stabilized with falsework, temporary braces, or holding cranes until a sufficient number of adjacent girders are erected with all diaphragms and crossframes connected to provide the necessary lateral stability.

**3.15.6.8** Splices and field connections of main stress carrying members shall be made with a minimum of 50 percent of the holes filled with approved high strength bolts and full size erection pins before the external support systems are released. At least one-half of this percentage shall be bolts, tightened to specification requirements. The bolts and pins shall be installed uniformly throughout the connection except that erection pins shall be used in the extreme corners of all main connections.

**3.15.6.9** Members to be assembled on the ground before erection shall be blocked to their proper no-load profile and 100 percent of the approved high strength bolts shall be installed and tightened to specification requirements before erecting the member. The "no-load" profile is the fully cambered condition with no dead load deflections. When members are assembled with their webs vertical, they shall be supported at intervals of 20 ft (6 m), or two tenths of the span length, whichever is less.

**3.15.6.10** Diaphragms and crossframes shall be installed as the work progresses to insure lateral stability of the members during all phases of the erection procedure.

**3.15.6.11** Between the first two lines of straight girders, each diaphragm or crossframe to girder connection shall be made with at least 50 percent of the holes filled with approved high strength bolts. The bolts shall be tightened until there is no gap between the connected parts. After the first two lines of girders are erected and stabilized, diaphragms or crossframes installed between subsequent lines of girders may have each of their connections made with a minimum of two approved high strength bolts installed in each connection unless a greater number of bolts is required for stability. The bolts shall be tightened until there is no gap between the connected parts.

**3.15.6.12** Between all lines of curved girders, each diaphragm or crossframe to girder connection shall be made with at least 50 percent of the holes filled with approved high strength bolts. The bolts shall be tightened until there is no gap between the connected parts.

**3.15.6.13** In bolted field splices, bolts shall be oriented so that the heads are visible to public view, unless directed otherwise. On fascia girders and beams, the bolt head shall be located on the outer web face. On all flanges, the bolt head shall be located on the bottom face.

### **3.15.7 Field Reaming and Drifting of Holes.**

**3.15.7.1** Members shall be subject to only light drifting to align holes. Any members subjected to drifting that results in distortion of the member or elongation of the holes will be rejected.

**3.15.7.2** No field reaming shall be performed on main member splice connections.

**3.15.7.3** Secondary members, i.e. diaphragms, crossframes, lateral bracing, etc., that have standard holes may be subjected to limited field reaming when approved by the Engineer. If approved, reaming shall not elongate holes by an amount greater than 1/16 in (1.6 mm) for 75 percent of the holes in any erection sub-assembly and 1/8 in (3 mm) for the remaining 25 percent. The following requirements shall also be met:

- (a) Reaming shall occur in only one component of the bolted connection.
- (b) Reaming shall only be done to the secondary member and not to connection or gusset plates welded to the main girder.
- (c) The reamed hole shall be covered with a hardened ASTM F 436 (ASTM F 436M) washer.

**3.15.7.4** Additional reaming of secondary members may be approved provided adequate edge distances and fastener spacings are maintained. In such case, the next larger fastener size shall be used. The edge distance shall be considered to be that governed by the original fastener size for a rolled or planed edge.

**3.15.7.5** Field reaming producing results exceeding the limits previously described, will be cause for rejection of the member.

**3.15.7.6** Secondary members with oversize holes (see Table 5) shall not be field reamed without approval.

### **3.16 Field Welding.**

**3.16.1 General.** Welding performed in the field on material that will become an integral part of the finished work or on any material used in a temporary capacity that will affect public safety shall be subject to all of the applicable requirements within this specification.

**3.16.2 Welder qualification.** Field welding shall only be performed by welders who have passed the qualification tests in conformance with the AASHTO Welding Specifications for the welding process and position, and material type and thickness required for the work. The minimum qualification shall be for “all-position” groove welding on “limited thickness” (3/4 in [20 mm] maximum) plate. (The qualification test consists of vertical-up and overhead groove welds on 3/8 in [10 mm] plate.) The welder must furnish acceptable proof of qualification, namely, AWS Certification or sworn copies of a satisfactory qualification test record or both. A welder’s qualification shall be considered as remaining in effect indefinitely unless the welder is not engaged in a given process of welding for which he is qualified for a period exceeding six months, or unless there is some specific reason to question the welder's ability.

**3.16.3 Process.** The shielded metal arc welding process (SMAW) is the only process approved for the field welding of structural steel. Welding shall only be done with low hydrogen electrodes (E 8018-C 3 with weathering steel or E 7018 with all other steels, unless approved otherwise).

**3.16.4 Approval.** Field welding of structural steel will not be permitted without approved drawings and welding procedures, unless approved otherwise.

**3.16.5 Weather conditions.** Welding shall not be performed when surfaces to be welded are wet from condensation, rain, snow or ice, when rain or snow is falling on the surfaces to be welded, or during periods of high wind unless the welder and the work are properly protected. Welding shall not be permitted when the temperature in the immediate vicinity of the welding is below 32 °F (0 °C). (The

## SECTION 550

environmental temperature may be below 32 °F [0 °C] but a heated structure or shelter around the area being welded shall maintain the temperature adjacent to the weldment at 32 °F [0 °C] or higher.)

**3.16.6 Surface preparation.** Surfaces to be welded and surfaces adjacent to the weld shall be free from loose or thick scale, slag, rust, moisture, grease, paint and other foreign material that would prevent proper welding. Surfaces shall be cleaned by blast cleaning or grinding to bare metal.

**3.16.7 Tack welds.** Tack welds are subject to the same quality requirements as the final weld, including preheat.

**3.16.8 Electrode storage and use.** Low hydrogen electrodes (E 7018) shall be kept until used in a portable holding oven heated and maintained at 250 °F (120 °C). Once removed from the oven for use, the electrodes may not be exposed to the atmosphere for more than 4 hours or they must be discarded. Wet electrodes shall not be used.

**3.16.9 Preheat and interpass temperatures.** All base metal being welded shall be preheated to a minimum of 200 °F (100 °C) (max. 400 °F [205 °C]) within an area 3 in (75 mm) minimum in all directions from the point of welding. This temperature must be maintained along the entire length of weld if more than one pass is required. Preheat temperatures shall be monitored with temperature indicating crayons.

**3.16.10 Clean up.** All weld slag shall be removed and the weld area suitably cleaned. Before painting, the weld area shall be power wire brushed or abrasively blast cleaned.

### **3.16.11 Nondestructive Testing & Weld Repair.**

**3.16.11.1** Nondestructive testing of field welds shall be performed when so required by the plans, special provisions, specifications or the Engineer. Each test shall be witnessed by an authorized representative of the Department.

**3.16.11.2** Welds or sections of welds containing imperfections and judged unacceptable by the Department shall be removed and rewelded at the Contractor's expense. Welds so removed and replaced will be reinspected by the Department by the same method of inspection and judged by the same criteria, or the entire piece shall be rejected as determined by the Engineer.

**3.16.11.3** All costs for the reinspection of defective welds shall be at the Contractor's expense.

**3.16.11.4** The Contractor shall furnish and properly locate suitable scaffolding, platforms or other means of accessibility to the area where testing is required.

### **3.16.12 Stud Welding.**

**3.16.12.1** Shear connectors used in composite beam construction shall be welded in place in accordance with the requirements of 547. Preheat shall not be required with the field use of automatically timed stud welding equipment, unless directed otherwise.

**3.16.12.2** Threaded fasteners (e.g. as stay-in-place form holddowns), if used, shall meet the requirements of 547, and torque tested as per AASHTO Welding Specifications, Chapter 7.

## **3.17 Field Painting.**

**3.17.1 General.** Field painting when called for on the plans shall include the proper preparation of the metal surfaces, the application, protection, and drying of the paint coatings, the protection of

pedestrian, vehicular, or other traffic upon or beneath the bridge structure, and the protection of all portions of the structure against disfigurement. Surfaces other than those where paint has been permitted to remain shall be primed the same day that the steel is cleaned. In case cleaned surfaces are left overnight without priming, the steel shall be blast cleaned again and then cleaned in accordance with 3.12.4 before priming. See the special provision for paint sampling and testing requirements.

**3.17.1.1** Existing dirt, dust and the debris from cleaning operations shall be removed from the roadway and structure to prevent the contamination of surfaces either prepared for paint or surfaces freshly painted. It may be necessary to remove or allay the dust on each end of the bridge to prevent traffic from picking it up. Repetitive operations will be required for the distance deemed necessary to assure protection for the paint surfaces.

**3.17.1.2** All necessary precautions shall be taken to prevent pollution and contamination of air and water during cleaning and painting operations. The precautions shall include, but not be limited to tarpaulins, plastic sheeting, plywood, and the like. The Contractor shall take prompt action to correct any noted deficiencies in methods. In populated areas, it may become necessary to control noise emissions from compressors.

**3.17.1.3** Care shall be taken to prevent damage to vegetation, water supplies, traffic, utilities, abutting properties, and the structure by equipment, personnel, and cleaning and painting operations. Any damage shall be promptly rectified. Any paint splatterings shall be removed and the surfaces shall be repaired.

**3.17.1.4** Materials shall be stored in an area protected from traffic. Approved storage areas shall be secured by the Contractor.

**3.17.1.5** The Contractor shall furnish an approved dry film thickness gauge with which to measure the dry paint film.

**3.17.2 Cleaning.** When all field connections have been completed and approved and before applying the first field coat of paint, the surface of the shop coat shall be thoroughly cleaned of all loose or foreign substances. Oil and grease shall be removed by the use of SSPC-SP 1, Solvent Cleaning. All unpainted or damaged surfaces including all areas showing any evidence of the presence of rust, shall be blast cleaned as specified in SSPC-SP 10, Near-White Blast Cleaning, unless other effective means are permitted. The blast cleaned surface shall be painted the same day it is blast cleaned.

**3.17.3 Retouching.** After the steel has been cleaned, all surfaces not covered by the full thickness of shop coat paint, including areas from which the paint has been previously omitted, has been worn off or removed, or has become damaged, shall be thoroughly coated with the primer and intermediate coats of the specified paint system. See 550.3.13.3.

**3.17.4 Weather conditions.** During surface preparation, coating application and four hours thereafter, the ambient environmental and steel temperature shall be between 50° and 100 °F (10° and 40 °C), the steel temperature shall be at least 5 °F (3 °C) above the dew point temperature, and the relative humidity shall not exceed 80 percent, unless manufacturer's recommendations state otherwise.

**3.17.5 Mixing and Thinning.**

**3.17.5.1** All ingredients in any container of paint shall be thoroughly mixed before use and shall be agitated often enough during application to keep the paint in a uniform condition.

## SECTION 550

**3.17.5.2** All pigmented paint shall be strained after mixing except where application equipment is provided with adequate strainers. Strainers shall be of a type to remove only skins and undesirable matter but not to remove the pigment.

**3.17.5.3** If it is necessary in cool weather to have the paint of a thinner consistency than when delivered in the containers, the paint may be thinned to spread more freely by heating in hot water or on steam radiators. No thinner shall be added to the paint unless necessary for proper application. Paints to be applied by brush will usually require no thinning. Paints to be sprayed, if not specifically formulated for spraying, may require thinning when proper adjustment of the spray equipment and air pressure does not result in satisfactory paint application.

**3.17.5.4** The type of thinner shall comply with the paint specification or manufacturer's recommendations.

**3.17.5.5** When the use of thinner is permissible, thinner shall be added to paint during the mixing process. All thinning shall be done under the supervision of one acquainted with the correct amount and type of thinner to be added to the paint.

**3.17.6 Application.** Painting shall be done in a neat and workmanlike manner. Paint shall be applied with hand brushes or rollers, by spraying, or with permission, by other methods. By any method, the coating of paint applied shall be smoothly and uniformly spread so that no excess paint will collect at any point and the paint shall evidence no defects which detract from the system's performance.

**3.17.6.1** When brushes are used, the following provisions shall apply to both field coats: To secure a maximum thickness of paint film upon rivet and bolt heads and nuts (connectors), and upon edges of shapes, the edges shall first be striped with a longitudinal motion and the connectors with a rotary motion of the brush. General painting of the whole surface, including the edges and connectors, may follow immediately.

**3.17.6.1.1** During general painting, the paint shall be so manipulated under the brush as to produce a smooth, uniform, even coating in close contact with the previously applied paint and the paint shall be worked into all corners and crevices.

**3.17.6.1.2** On all surfaces which are inaccessible to paint brushes, the paint shall be applied by spraying, with sheepskin daubers, or by other approved methods to insure thorough covering.

**3.17.6.2** When spray equipment is used, the power equipment shall be capable of applying the paint in a fine, even spray. Connectors and edges of shapes shall be covered with preliminary passes of the spray gun or shall be striped by brushing as per 3.17.6.1. Care shall be exercised that adequate thickness of wet paint is deposited. When it becomes necessary to build the film thickness, the areas to be painted shall be sprayed horizontally and vertically, with ample overlapping. This may be repeated to gain film build. Areas inaccessible to the spray pattern shall be spot primed before spraying or shall be touched up by the use of brushes or the like after spraying.

**3.17.7 Field coats.** Field coats shall be applied as detailed in a special provision. All oil, grease, dirt, or salt deposited on the surfaces to be painted shall be removed before applying each successive coat of paint. Special recommendations of the manufacturer shall be followed exactly.

**3.17.7.1** Prior to painting, weld surfaces shall be power wire brushed or abrasively blast cleaned. Prior to painting, galvanized surfaces shall be pretreated with SSPC-SP1, Solvent Cleaning, using zinc phosphate or a light acid without attacking the zinc, to remove soluble contaminants, and abrasive blasting or other mechanical means to remove insoluble contaminants such as zinc hydroxide (i.e. white rust) and to thoroughly roughen the entire surface and produce a uniform anchor profile of 1 to 1.5 mils

(25 to 38  $\mu\text{m}$ ) without removing the zinc layer. Alternate pretreatments or tie-coats may be considered if recommended by the coatings manufacturer and approved by the Department.

**3.17.7.2** Surfaces which have been galvanized or shop painted with zinc rich paint and have become damaged after being coated shall be pretreated as specified in 3.17.7.1 and shall be repaired with 2 coats of zinc-rich primer, 708-NH 1.60. The second coat shall not be applied until the first coat has been approved.

**3.17.8 Paint thickness.** The total dry film thickness of the complete system (shop and field coats) shall be as specified in a special provision. The procedure to measure the dry film thickness shall be in accordance with SSPC-PA 2.

**3.17.9 Removal of paint.** If the painting is unsatisfactory, the paint shall be removed and the metal thoroughly cleaned and repainted.

### **3.18 Field Cleaning of Weathering Steel.**

**3.18.1** All detrimental substances such as oil, dirt, grease, chalk and the like remaining after erection shall be removed as soon as possible. Concrete spatter shall be washed off immediately. To obtain a uniformly rusted appearance, the entire exterior fascias of the outside beams or girders shall be cleaned by means of brush-off blast cleaning in accordance with SSPC-SP 7.

### **3.19 Removal of Rust and Stains from Concrete.**

**3.19.1** In the final stage of construction, all rust and other stains shall be removed from the exposed surfaces of the substructure, using approved methods. Ferrous stain remover shall be a product as included under section 537 of the Qualified Products List.

### **3.20 Fracture Control Plan.**

**3.20.1 Specifications.** Fracture critical members shall conform to the following requirements and the AASHTO Welding Specifications, Chapter 12.

**3.20.2 Modifications to ASTM A 6/A 6M.** The quality of steel plates shall meet the general requirements of Article 9, ASTM A 6/A 6M, with the following modifications:

- (a) Mill conditioning and exploration will be limited to grinding or arc-air gouging. No welding at the mill is allowed.
- (b) The ground or gouged areas deeper than 1/16 in (1.5 mm) shall not exceed 2% of the area of the surface being ground (conditioned).
- (c) After grinding, the net cross-sectional area shall not be less than 98% of the nominal cross-sectional area of the plate.
- (d) The thickness of the plate after removal of imperfections must not be reduced by more than 15% of the nominal thickness.
- (e) Weld repairs may be made in the fabrication shop in accordance with 550 and the AASHTO Welding Specifications.

**3.20.3 Additions to ASTM A 6/A 6M.** The quality of steel plates shall meet the general requirements of Article 9, ASTM A 6/A 6M, with the following additions:

- (1) Surface imperfections. All injurious surface imperfections shall be removed by the manufacturer of discrete cut length plates.

## SECTION 550

a. Shallow imperfections shall be ground to sound metal; the ground area shall be well faired and the thickness of the ground plate shall not be reduced below the minimum thickness permitted.

b. All surface imperfections, the removal of which will reduce the plate thickness below this minimum, shall be cause for rejection of the plate; however, by agreement with the purchaser, the metal so removed may be replaced with weld metal as provided in ASTM A 6/A 6M, 9.5.

**3.20.4 Qualification of fillet welds.** Prior to welding Fracture Critical Members the use of a 90 degree included angle shall be specified in qualification testing fillet-welding procedures, with the test plate welded in the position(s) of welding to be used in fabrication. The test weld shall be made with the same procedure and the same number of passes as will be used in production.

### Method of Measurement

**4.1** Structural steel and bridge shoes will not be measured, but shall be the pound (kilogram) or Each, respectively, final pay quantities in accordance with 109.11 for structural steel and bridge shoes required as shown on the plans.

**4.1.1** Pier nose protection steel shall be included as part of the item of structural steel unless otherwise shown on the plans.

### Basis of Payment

**5.1** Except as provided in 544.5.2, structural steel and bridge shoes are final pay quantity items and will be paid for at the Contract unit price per pound (kilogram) or each respectively complete in place in accordance with 109.11.

**5.1.1** The cost of inspection facilities, quality control inspection, tests, including equipment, supplies and technicians, to evaluate material, retests of unacceptable work, any necessary repairs, painting, and other items necessary for the proper completion of the work in accordance with the Contract shall be subsidiary.

#### Pay items and units:

550.1 _ _	Structural Steel (F)	Pound (Kilogram)
550.2 _ _	Bridge Shoes (F)	Each

## SECTION 556 -- PAINTING EXISTING STRUCTURAL STEEL

### Description

**1.1** This work shall consist of field cleaning, and painting existing structural steel and bridge shoes that have been erected by others, using pollution control methods, as shown on the plans and specified in a special provision.

**1.2** The location of the structures and the painting requirements will be described on the plans and in a special provision.

### Materials

**2.1** Paint shall conform to 708.

**2.2** Abrasive material shall have a maximum particle size not larger than that passing through a No. 16 (1.18 mm) mesh screen, U.S. sieve series.

**Construction Requirements**

**3.1 Field Painting.**

**3.1.1 General.** Requirements for field painting shall be as specified in 550.3.17 and a special provision.

**3.2 Special Requirements.**

**3.2.1** Loading and unloading of materials on the bridge will be permitted only with appropriate safeguards for traffic, such as construction signs and warning devices as required in the Manual on Uniform Traffic Control Devices (MUTCD), uniformed officers, and the like, and only at such times as may be permitted.

**3.2.2** Temporary suspension of work may be required during periods when the traffic load is such that hazardous conditions would result from interference with the normal flow of traffic.

**3.2.3** During field painting the Contractor shall provide appropriate safety measures, approved by the Department, for the protection of the public against damage due to paint drippings, paint spatter, wind blown paint, falling objects, etc. The Contractor shall be fully responsible for property damage or personal injury which may result from operations incidental to the field painting of structural steel. The State shall be protected and indemnified in accordance with Section 107.01.

**3.2.4** The applicable portions of 618 and 619 will apply to this item as though contained herein and will be subsidiary unless these items are included in the contract.

**3.2.5** Special signing requirements may be detailed in a special provision.

**3.2.6** The paint system shall at all times during its application or repair be protected from dust, either caused by construction activities or by traffic, that may adhere to the uncured coating. When ordered the entire upper surface of concrete bridge seats shall be cleaned of all dirt and debris before beginning to paint the bridge shoes.

**Method of Measurement**

**4.1** This item will be measured as a unit. When more than one unit is specified in the contract, separate item numbers will appear for each separate and complete unit.

**Basis of Payment**

**5.1** The accepted quantity of painted structural steel will be paid for at the contract lump sum price.

**Pay item and unit:**

556	Painting Existing Structural Steel	Unit
-----	------------------------------------	------

## SECTION 560

### *SECTION 560 -- PREFABRICATED COMPRESSION SEAL EXPANSION JOINT*

#### **Description**

**1.1** This work shall consist of furnishing and installing a watertight prefabricated expansion joint utilizing a single elastomeric compression seal, as shown on the plans.

#### **Materials**

**2.1** The compression seal shall be elastomeric material conforming to AASHTO M220 and meet the configuration shown on the plans and shall be a product as included on the Qualified Products List. Each seal shall be furnished full length. Splices in the length of an individual seal will not be permitted unless the splices are made at the plant by the manufacturer of the seal with the approval of the Department.

**2.1.1** The seal material shall be identified with the production date, manufacturer's name or trademark, and lot number.

**2.2** Steel members shall comply with AASHTO M 183/M 183M (ASTM A 36/A 36M), unless specified otherwise on the plans.

**2.2.1** Studs shall meet the requirements of AASHTO M 169 (ASTM A 108).

**2.3** Paint shall conform to 708.

**2.4** Lubricant-adhesive shall be a one-part, moisture curing polyurethane and aromatic hydrocarbon solvent mixture with the following physical properties:

Average weight	8 lb/gal $\pm$ 10 % (1 kg/L $\pm$ 10 %)
Solids content by weight (minimum)	65 percent
Adhesive to remain fluid from	5° to 120 °F (-15° to 50 °C)
Film strength, min. (ASTM D 412)	2,000 psi (13.8 MPa)
Elongation	250 percent

**2.4.1** Each lot of adhesive shall be delivered in containers plainly marked with the manufacturer's name or trademark and shall be accompanied by the manufacturer's affidavit attesting conformance with the specification.

**2.5** Concrete bonding agent shall consist of a flexible low-modular, epoxy bonding agent as included under Section 520 of the Qualified Products List to be used as shown on the plans or ordered. A list of materials approved for bonding steel to fresh concrete is available from the Bureau of Materials and Research.

#### **Construction Requirements**

**3.1 General.** The expansion joint assembly shall be fabricated at a plant with an AISC Category SBR certification. See 550.3.2.

### 3.2 Fabrication.

**3.2.1** Shop fabrication drawings showing all details of the complete expansion joint assembly shall be submitted for approval in accordance with 105.02. Approval of the shop fabrication drawings shall be required prior to the manufacture of the assembly. Detailed welding procedures shall be considered an integral part of shop fabrication drawings and shall be submitted for approval along with the shop fabrication drawings. The shop fabrication drawings shall indicate the welding procedure to be used for each weld shown. The name of the manufacturer of the elastomeric compression seal shall be shown on the shop fabrication drawings. Original shop fabrication drawings, corrected, shall be delivered to the Department before the final payment is made.

**3.2.2** Fabrication and workmanship shall be performed in accordance with the applicable provisions of 550.3.

**3.2.3 Preblast.** All steel elements shall be blast cleaned before fabrication in conformance with the requirements of SSPC-SP 10, Near White Blast Cleaning.

**3.2.4** Welding of steel shall be performed in accordance with 550.3.6. Welding shall be performed by prequalified welders and welding operators.

#### 3.2.5 Stud Welding.

**3.2.5.1** The welding of studs shall meet the requirements of the AASHTO Welding Specifications, Section 7 (see 550.3.6.10).

**3.2.5.2 Automatic equipment.** Studs shall be welded with automatically timed stud welding equipment connected to a suitable source of direct current straight polarity power. Welding voltage, current, time, and gun settings for lift and plunge should be set at optimum settings, based on past practice, recommendations of stud and equipment manufacturer, or both. AWS C5.4, Recommended Practices for Stud Welding, should also be used for technique guidance.

**3.2.5.3 Testing.** Ten percent (10%) of welded studs shall be tested. The test shall consist of bending the studs, after they are allowed to cool, to an angle of approximately 15 degrees from their original axes by either striking the studs on the head with a hammer or placing a pipe or other suitable hollow device over the stud and manually or mechanically bending the stud. If any studs fail the test, then all studs shall be tested. Acceptable bent studs shall be left in the bent position.

**3.2.6** Painting shall be done in the shop. Except for areas in direct contact with the seal, all metal surfaces of the prefabricated assembly, shall be painted with one coat of approved zinc-rich primer to a dry film thickness of at least 3 mils (75  $\mu\text{m}$ ).

**3.2.7** Cleaning the mating surfaces of the steel elements shall be performed just prior to installing the seal. The steel surfaces shall be blast cleaned and the seal surfaces cleaned in accordance with the manufacturer's recommendations.

**3.2.7.1** The seal elements shall be securely bonded in place with sealant adhesive.

**3.2.8** Shipping and adjusting devices required to ship, install, and adjust the joint assembly on the bridge shall be provided at approximately 4 ft (1 m) spacings and shall be furnished and installed by the fabricator. Immediately after the joint has been secured to the structural steel and the abutment, the shipping and adjustment devices shall be removed and any bolt holes plug welded. Any welds on exposed surfaces shall be ground smooth and damage to exposed painted surfaces shall be repaired with an approved zinc-rich primer.

## SECTION 560

### 3.3 Inspection.

**3.3.1 Notice.** The fabricator shall give ample notice (two weeks minimum) of the beginning of work so that arrangements can be made for inspection. No materials shall be fabricated before the Engineer has been so notified.

**3.3.2** The Department will inspect the fabrication of expansion joints. This inspection will include the examination of materials, welding, testing, work procedures, painting, and the final fabricated product.

**3.3.3** The Engineer may waive shop inspection and make a complete inspection at a later stage in the construction sequence.

**3.4 Installation.** The joint assembly shall be installed in the bridge as shown on the plans, as recommended by the manufacturer, and as ordered.

**3.4.1** The steel and concrete surfaces adjacent to the blockout shall be cleaned thoroughly, employing blast cleaning as required

**3.4.2** Class AA concrete shall be placed as blockout filler as directed.

### Method of Measurement

**4.1** Prefabricated compression seal expansion joints will not be measured, but shall be the linear foot (linear meter) final pay quantities in accordance with 109.11 for expansion joints required as shown on the plans.

### Basis of Payment

**5.1** Prefabricated compression seal expansion joints are final pay quantity items and will be paid for at the Contract unit price per linear foot (linear meter) complete in place in accordance with 109.11.

#### Pay item and unit:

560.1	Prefabricated Compression Seal Expansion Joint (F)	Linear Foot (Linear Meter )
-------	---	-----------------------------

## SECTION 561 -- PREFABRICATED EXPANSION JOINT

### Description

**1.1** This work shall consist of furnishing and installing a watertight prefabricated expansion joint utilizing either a single extruded locking elastomeric strip seal, or multiple modular extruded locking box or strip seals, or a prefabricated finger joint as shown on the plans.

### Materials

**2.1** The seal, except as provided in 2.1.1, shall be elastomeric material conforming to AASHTO M 220 meeting the configuration as shown on the plans and shall be a product as included on the Qualified

Products List. Each seal shall be furnished full length. Splices in the length of an individual seal will not be permitted unless the splices are made at the plant by the manufacturer of the seal with the approval of the Department.

**2.1.1** The requirements for recovery set forth in Table 1 of AASHTO M 220 will not apply.

**2.1.2** The seal material shall be identified with the production date, manufacturer's name or trademark, and lot number.

**2.2 Steel members.** Extruded steel sections and rolled steel plates and sections shall conform to AASHTO M 222/M 222M (ASTM A 588/A 588M) or AASHTO M 183/M 183M (ASTM A 36/A 36M), as shown on the plans.

**2.2.1** Studs shall meet the requirements of AASHTO M 169 (ASTM A 108).

**2.3** When the plans show the modular box seal, the seal end plug shall be a flexible polyurethane foam bonded to the end of the elastomeric box seal.

**2.4** When the plans show the modular box or modular strip seal, the following shall be adhered to:

Stainless steel bearing plates: ASTM A 276

Upper Compression Springs and Lower Bearing Blocks: urethane rubber, epoxy blend and Teflon; configuration as shown on the plans.

Elastomeric Control Springs: dense polyurethane foam with nylon dowels; configuration and location as shown on the plans.

**2.5 Painting.** Except for areas in direct contact with the seal, all metal surfaces of the prefabricated assembly shall be painted with one coat of approved zinc-rich primer to a dry film thickness of at least 3 mils (75  $\mu$ m).

**2.6** Lubricant-adhesive shall be a one-part, moisture curing polyurethane and aromatic hydrocarbon solvent mixture with the following physical properties:

Average weight	8 lb/gal $\pm$ 10 % (1 kg/L $\pm$ 10 %)
Solids content by weight (min.)	65 percent
Adhesive to remain fluid from	5° to 120 °F (-15° to 50 °C)
Film strength, min. (ASTM D 412)	2,000 psi (13.8 MPa)
Elongation	250 percent

**2.6.1** Each lot of adhesive shall be delivered in containers plainly marked with the manufacturer's name or trademark and shall be accompanied by the manufacturer's affidavit attesting to conformance with the specification.

**2.7** Concrete bonding agent shall consist of a flexible low-modular, epoxy bonding agent as included under section 520 of the Qualified Products List, to be used as shown on the plans or ordered.

**2.8** When the plans show a prefabricated finger joint, the preformed fabric trough shall be a product included on the Qualified Products List:

## SECTION 561

**PREFORMED FABRIC** shall be a multi-layer sheet composed of multi-ply of 15 oz. per square yard (5%) polyester laminated with butadiene acrylonitrile and vulcanized to form an integral laminate.

<b>Physical Properties</b>	
Number of Plies	3
Minimum Weight of Laminate (lbs/sq. ft.)	0.85
Minimum Thickness (inches)	5/32
Minimum Ultimate Tensile Strength of Laminate ((lbs/in) of width)	1,200
Maximum Elongation at Ultimate Tensile Strength	30%
Maximum Elongation at 1/10 Ultimate Tensile Strength	3%

### Construction Requirements

**3.1 General.** The expansion joint assembly shall be fabricated at a plant with an AISC Category SBR certification. See 550.3.2.

#### 3.2 Fabrication.

**3.2.1** Shop fabrication drawings showing all details of the complete expansion joint assembly shall be submitted for approval in accordance with 105.02. Approval of the shop fabrication drawings shall be required prior to the manufacture of the assembly. Detailed welding procedures shall be considered an integral part of shop fabrication drawings and shall be submitted for approval along with the shop fabrication drawings. The shop fabrication drawings shall indicate the welding procedure to be used for each weld shown. The name of the manufacturer of the elastomeric seal shall be shown on the shop fabrication drawings. Original tracings of all shop fabrication drawings, corrected, shall be delivered to the Department before final payment is made.

**3.2.2** Fabrication and workmanship shall be performed in accordance with the applicable provisions of 550.3.

**3.2.3 Preblast.** All steel elements shall be blast cleaned in conformance with the requirements of SSPC-SP 10, Near White Blast Cleaning, before fabrication.

**3.2.4** Welding of steel shall be performed in accordance with 550.3.6. Welding shall be performed only by prequalified welders and welding operators.

#### 3.2.5 Stud Welding.

**3.2.5.1** The welding of studs shall meet the requirements of the AASHTO Welding Specifications, Section 7 (see 550.3.6.10).

**3.2.5.2 Automatic equipment.** Studs shall be welded with automatically timed stud welding equipment connected to a suitable source of direct current straight polarity power. Welding voltage, current, time, and gun settings for lift and plunge should be set at optimum settings, based on past practice, recommendations of stud and equipment manufacturer, or both. AWS C5.4, Recommended Practices for Stud Welding, should also be used for technique guidance.

**3.2.5.3 Testing.** Ten percent (10%) of welded studs shall be tested. The test shall consist of bending the studs, after they are allowed to cool, to an angle of approximately 15 degrees from their original axes by either striking the studs on the head with a hammer or placing a pipe or other suitable hollow device over the stud and manually or mechanically bending the stud. If any studs fail the test, then all studs shall be tested. Acceptable bent studs shall be left in the bent position.

## SECTION 561

**3.2.6** Painting shall be performed in the shop. Except for areas in direct contact with the seal, all metal surfaces of the prefabricated assembly shall be painted with one coat of approved zinc-rich primer to a minimum dry film thickness of 3 mils (75  $\mu\text{m}$ ).

**3.2.7** Cleaning the mating surfaces of the steel and the elastomeric seal elements shall be performed just prior to installing the seal. The steel surfaces shall be blast cleaned and the seal surfaces cleaned in accordance with the manufacturer's recommendations.

**3.2.7.1** The seal elements shall be securely bonded in place with sealant adhesive.

**3.2.8** When the plans show a modular box or modular strip seal, the following shall apply:

- (a) The stainless steel plates shall be firmly attached to the support bars.
- (b) During assembly of the support bar bearings, a pre-load shall be applied to prevent noise and looseness of the support bars.
- (c) Centering devices as required for the separation beams shall be attached to the support bars.

**3.2.9** Shipping and adjusting devices required to ship, install, and adjust the joint assembly on the bridge shall be provided at approximately 4 ft (1 m) spacings and shall be furnished and installed by the fabricator. Immediately after the joint has been secured to the structural steel and the abutment, the shipping and adjustment devices shall be removed and any bolt holes plug welded. Any welds on exposed surfaces shall be ground smooth and damage to exposed painted surfaces shall be repaired with an approved zinc-rich primer.

### **3.3 Inspection.**

**3.3.1 Notice.** The fabricator shall give ample notice (two weeks minimum) of the beginning of work so that arrangements can be made for inspection. No materials shall be fabricated before the Engineer has been so notified.

**3.3.2** The Department will inspect the fabrication of expansion joints. This inspection will include the examination of materials, welding, testing, work procedures, painting, and the final fabricated product.

**3.3.3** The Engineer may waive shop inspection and make a complete inspection at a later stage in the construction sequence.

**3.4 Installation.** The joint assembly shall be installed in the bridge as shown on the plans, as recommended by the manufacturer, and as ordered.

**3.4.1** The steel and concrete surfaces adjacent to the blockout shall be cleaned thoroughly, employing blast cleaning as required, and an approved bonding agent applied as shown on the plans.

**3.4.2** Class AA concrete shall be placed as blockout filler as directed.

**3.4.3** When the plans show the modular box or modular strip seal, the expansion joint assembly shall be installed on the bridge under the supervision of the manufacturer's representative.

**3.5** A water collection and drainage system shall be located at the end of the fabric trough. The drainage system shall catch and channel all water to a point where it can be discharged away from the superstructure and substructure.

## SECTION 561

**3.5.1** The pipe and pipe drain shall be secured to the steel superstructure and the concrete substructure at 10-foot intervals (maximum) or as shown on the plans or as directed by the Engineer.

**3.5.2** Sharp bends in the pipe which might allow sediment to collect will not be permitted.

### Method of Measurement

**4.1** Prefabricated expansion joints, of the type specified, will not be measured, but shall be the linear foot (linear meter) final pay quantities in accordance with 109.11 for prefabricated expansion joints required as shown on the plans.

**4.1.1** Expansion joint assemblies utilizing a single extruded locking elastomeric strip seal will be measured as "Type A" assemblies.

**4.1.2** Expansion joint assemblies utilizing multiple modular extruded locking elastomeric strip seals will be measured as "Modular Type A" assemblies.

**4.1.3** Expansion joint assemblies utilizing finger plates and a fabric trough will be measured as "Finger Joint" assemblies.

**4.1.4** Expansion joint assemblies utilizing multiple modular extruded locking elastomeric box seals will be measured as "Modular Type B" assemblies.

### Basis of Payment

**5.1** Prefabricated expansion joints, of the type specified, are final pay quantity items and will be paid for at the Contract unit price per linear foot (linear meter) complete in place in accordance with 109.11

#### Pay items and units:

561.110	Prefabricated Expansion Joint Type A (F)	Linear Foot (Linear Meter)
561.111	Prefabricated Expansion Joint, Modular Type A (F)	Linear Foot (Linear Meter)
561.211	Prefabricated Expansion Joint, Modular Type B (F)	Linear Foot (Linear Meter)
561.30	Prefabricated Expansion Joint, Finger Joint (F)	Linear Foot (Linear Meter)

## SECTION 562 -- ELASTOMERIC SEALANT

### Description

**1.1** This work shall consist of furnishing and placing a one-component or a two-component cold applied elastomeric type joint sealing compound, including curing agents, for caulking and sealing of the control joints of structures as shown on the plans or ordered.

### Materials

- 2.1** Primer furnished shall be as recommended by the manufacturer of the joint sealant.
- 2.2** Sealant for vertical joints shall be concrete gray in color and conform to ASTM C 920, type S or M, grade NS, class 25, with a use code of M and either T or NT and shall be a products as included on the Qualified Products List.
- 2.3** Sealant for horizontal joints shall be concrete gray in color and conform to ASTM C 920 type S or M, grade P or NS, class 25, with a use code of M and T and shall be a product as included on the Qualified Products List.
- 2.4** Requests for approval of a specific product shall be made in sufficient time for the material to be evaluated.

### Construction Requirements

- 3.1 Joint preparation.** The joints shall be thoroughly cleaned of all scale, rust, loose concrete, dirt, dust or other foreign matter. Projections of concrete into the joint space shall be removed.
- 3.1.1** The joints shall be cleaned by means of abrasive blast cleaning and loose particles removed. At the time of application, joints shall be clean, sound and dry.
- 3.1.2** For horizontal joints, the use of compressible backing material, such as styrofoam, shall be employed to insure that the depth of the cured sealant shall be no greater than 1/2 in (12 mm). The depth of the sealant shall not be greater than one half the width of the joint unless otherwise shown on the plans. A bond breaker material such as polyethylene tape shall be used at the sealant backing interface. The use of grease or oil will not be permitted.
- 3.1.3** For vertical joints, backup material shall be used where necessary and sealant shall be applied to a maximum depth of 1/2 in (12 mm) by use of a caulking gun.
- 3.2 Weather.** The application of the sealant shall be applied at temperatures between 40° and 120 °F (4° and 50 °C).
- 3.3 Primer.** The primer shall be applied to the sides of the joint and allowed to dry tack free. Primer application shall be in accordance with the manufacturer's specifications.
- 3.4 Sealant.** As soon as the primer has set, the sealant shall be introduced into the joint in accordance with the recommendations of the manufacturer and as directed by the Engineer. The joint shall not be filled flush, but shall be left approximately 1/4 in (6 mm) below the surface. The joint shall be protected from disturbance until it has set up tack free.

### Method of Measurement

- 4.1** Elastomeric sealant will not be measured.

### Basis of Payment

- 5.1** Elastomeric primer and sealant material will be subsidiary to the concrete to which it is applied.

## SECTION 563

### SECTION 563 -- BRIDGE RAIL

#### Description

**1.1** This work shall consist of furnishing and erecting railings for bridges and retaining walls in conformity with details shown on the plans or ordered. This work shall include anchor bolts or insert sleeves to support the railing and all construction above the top of the curb or sidewalk.

**1.2 Designations.** Bridge rails are classified as follows:

Type	Bridge Railing
Steel Tube Railing, 2 Rail	ST
Steel Tube Railing, 2 Rail (PL2)	T2
Steel Tube Railing, 4 Rail (PL2)	T4
W-Beam with Steel Tubing	T101
Aluminum Railing	F

**1.3** This work shall consist of furnishing and erecting protective screening or snow fence in conformity with details shown on the plans or ordered. Aluminum and steel components for screening may not be interchanged, and shall conform to the material requirements as detailed on the plans or as stated herein.

#### Materials

**2.1** Structural steel shall conform to the requirements of AASHTO M 270/M 270M Gr 50 (345) (ASTM A 709/A 709M Gr 50 [345]) unless otherwise specified on the plans, except anchor plates may be Grade 36 (250).

**2.1.1** Galvanized W-Beam sections shall comply with 606.2.4.

**2.2** Steel pipe shall conform to ASTM A 53, Grade B, seamless unless specified otherwise on the plans.

**2.3** Steel rail tubing shall conform to ASTM A 500, Grade B, unless otherwise specified on the plans. The tubing shall meet the Charpy V-notch toughness requirement of 15 ft-lbs (20 N-m) at 0 °F (-18 °C). CVN test samples shall be taken after forming the tubes.

**2.3.1** For steel tubing rail-to-post fasteners shall be ASTM A325 round-head bolts or ASTM A 276 Type 304 stainless steel threaded studs. All other fasteners may be ASTM A 307 bolts with ASTM A 563 nuts or cap screws. Anchor rods shall be ASTM A 449 with ASTM A 563 nuts.

**2.4** Galvanizing shall conform to AASHTO M 111 (ASTM A 123) for structural steel posts and tubing, AASHTO M 232 (ASTM A 153) for bolts, nuts, and washers, and conform to ASTM A 385 to provide adequate precautions (e.g. vent holes) for a quality product. The galvanizing kettle shall have 0.05 to 0.09 percent nickel. If the galvanizing is to be painted or powder coated, follow the requirements of Section 708-Appendix A and B.

**2.5** The material requirements of 606 shall apply for W-beam guardrail, thrie-beam guardrail, or tubular thrie-beam guardrail..

**2.6** Aluminum railing and aluminum and steel appurtenances shall conform to the pertinent materials specified in the latest edition of "A Guide To Standardized Highway Barrier Rail Hardware", by the AASHTO-AGC-ARTBA Joint Cooperative Committee, ARTBA (formerly Technical Bulletin No. 268-B AGC Standard Form No. 131, June 1979) as amended.

**2.6.1** Stainless steel studs shall meet the requirements of ASTM A 276, Type 304 modified or Type 430 modified, each to 100,000 psi (689 MPa) tensile strength with 15 percent elongation.

**2.7** Preformed bearing pads shall be a single sheet approximately 1/8 in (3 mm) thick, in the required dimensions shown on the plans they shall be a products as included on the Qualified Products List, and meeting the requirements of either one of the following:

(a) M 251 pads - Plain or fabric-reinforced elastomeric pads conforming to AASHTO M251 meeting the elastomer properties of 50 Shore A-durometer (minimum) material, adequate for 1,000 psi (6.9 MPa) design compression stress, and meeting Level I test requirements with no cracks after the compressive load test, or

(b) Random-oriented fiber pads consisting of a fabric and rubber body made with new unvulcanized rubber and unused fabric or synthetic fibers and vulcanized with a proportion of fiber content sufficient to maintain strength and stability. Rubber shall be polyisoprene (natural rubber) or polychloroprene (neoprene). The surface hardness shall be minimum  $80 \pm 5$  Shore A-durometer. The ultimate breakdown limit of the pad under compressive loading shall be no less than 7,000 psi (48 MPa) without splits and without deformations exceeding 10 percent of thickness after removing the load.

**2.8** Protective screening and snow fence materials shall conform to the following:

**2.8.1** Aluminum components shall meet the material requirements of Standard No. BR-R12 (BR-R12 M) except as noted below.

**2.8.1.1** Aluminum chain link fabric shall be 1 1/2" (38 mm) mesh conforming to ASTM B211 Alloy 6061-T94. Chain link fabric shall have a knuckled finish on the top and bottom.

**2.8.1.2** Aluminum tie material shall be 6 gauge conforming to ASTM B211 F626-96A. Use double pig-tailed ties to attach all fabric to horizontal and vertical pipe rail. Tie bands shall be allowed for attaching the fabric to the framework.

**2.8.2** Steel components shall meet the material requirements shown on the plans, except as noted below.

**2.8.2.1** Steel chain link fabric shall be 9 gauge 1 1/2" (38 mm) mesh conforming to AASHTO M181 Type II (aluminum coated steel). Chain link fabric shall have a knuckled finish on the top and bottom.

**2.8.2.2** Aluminum ties shall be used with aluminum coated steel fabric and conform to 2.8.1.2.

### Construction Requirements

**3.1 General.** Bridge rail shall be fabricated at a plant with an AISC Category SBR certification. See 550.3.2.

### 3.2 Fabrication.

**3.2.1** Shop fabrication drawings shall be submitted for approval in accordance with 105.02.

## SECTION 563

**3.2.1.1** The shop fabrication drawings shall show the lengths of all individual rail sections and locations of all field splices. Rail sections shall be supplied in continuous lengths as shown or specified on the plans. Butt welding of short pieces of rail to form the specified continuous length of rail section will not be permitted. If approved, shop splices shall be made by complete penetration groove welds and inspected by ultrasonic testing.

**3.2.2** Steel railings shall be constructed in accordance with the plans, the pertinent provisions of 550.3, or as directed.

**3.2.2.1** Welding of steel shall be done in accordance with 550.3.6. Welding shall be performed only by prequalified welders and welding operators.

**3.2.2.2** Threaded studs shall be welded on after the tubes are galvanized by spot grinding off the galvanizing, welding on the studs, and repairing the damaged galvanized coating as per 3.2.2.3.

**3.2.2.3** Damaged galvanized coating shall be repaired by cleaning, pretreating, and painting as specified in 708-Appendix A section 3.6.

**3.2.2.4** Galvanized rail tubes, posts, and components shall be stored in a manner to prevent wet storage stain. Material shall be stored off the ground and individual elements separated with spacers to prevent contact between adjacent surfaces and to provide free and adequate circulation of air. Rail shall be inclined to provide continuous drainage and prevent ponding of water.

**3.2.2.4.1** Remove all 'white rust' (i.e. a build-up of zinc corrosion products- see 708-Appendix A) from galvanized surfaces formed due to wet storage. Loose powders shall be removed with a stiff nylon bristle brush. Heavier accumulations of white rust shall be removed with a more vigorous treatment using brushing and approved solvents. Removing the white rust is essential to the proper formation over time of proper zinc carbonate layers on the galvanized surface.

**3.2.3** Aluminum railing shall be constructed in accordance with the details shown on the plans.

**3.2.3.1** Welding of aluminum shall conform to 716.

**3.2.3.2** All aluminum surfaces, including shims, to be placed in contact with concrete shall be given a heavy coat of asphalt-base aluminum roof coating.

**3.2.3.3** Aluminum shims in thicknesses of 1/16 in, 1/8 in, and 1/4 in (1.5 mm, 3 mm and 6 mm) shall be furnished in sufficient quantities to permit adjustment of the rail alignment. The shims shall be the size of the bearing area and may be slotted for ease of installation. The shapes shall be shown on the shop drawings.

### Method of Measurement

**4.1** Bridge rail, of the type specified, will not be measured, but shall be the linear foot (linear meter) final pay quantities in accordance with 109.b11 for bridge rail required as shown on the plans.

### Basis of Payment

**5.1** Bridge rail, of the type specified, is a final pay quantity item and will be paid for at the Contract unit price per linear foot (linear meter) complete in place in accordance with 109.11.

**5.2** All miscellaneous hardware needed to connect the protective screening or snow fence to the rail will not be paid for separately but will be considered subsidiary to the appropriate bridge rail item.

## SECTION 563

### Pay items and units:

563.12	Bridge Rail ST (F)	Linear Foot (Linear Meter)
563.22	Bridge Rail T2 (F)	Linear Foot (Linear Meter)
563.221	Bridge Rail T2 with Protective Screening (F)	Linear Foot (Linear Meter)
563.223	Bridge Rail T2 with Snow Screening (F)	Linear Foot (Linear Meter)
563.23	Bridge Rail T3 (F)	Linear Foot (Linear Meter)
563.231	Bridge Rail T3 with Protective Screening (F)	Linear Foot (Linear Meter)
563.24	Bridge Rail T4 (F)	Linear Foot (Linear Meter)
563.241	Bridge Rail T4 with Protective Screening (F)	Linear Foot (Linear Meter)
563.243	Bridge Rail T4 with Snow Screening (F)	Linear Foot (Linear Meter)
563.3	Bridge Rail T101 (F)	Linear Foot (Linear Meter)
563.72	Bridge Rail F (2-bar) (F)	Linear Foot (Linear Meter)
563.73	Bridge Rail F (3-bar) (F)	Linear Foot (Linear Meter)
563.8	Resetting Bridge Rail (F)	Linear Foot (Linear Meter)
563.81	Rehabilitation of Bridge Rail (F)	Linear Foot (Linear Meter)
563.84	Temporary Bridge Rail (F)	Linear Foot (Linear Meter)
563.94	Protective Screening for Overpass Structures (F)	Linear Foot (Linear Meter)
563.721	Bridge Rail F (2-Bar) with Protective Screening (F)	Linear Foot (Linear Meter)
563.723	Bridge Rail F (2-Bar) with Snow Screening (F)	Linear Foot (Linear Meter)
563.731	Bridge Rail F (3-Bar) with Protective Screening (F)	Linear Foot (Linear Meter)
563.733	Bridge Rail F (3-Bar) with Snow Screening (F)	Linear Foot (Linear Meter)

## SECTION 565 -- BRIDGE APPROACH RAIL

### Description

1.1 This work shall consist of the furnishing and erecting of bridge approach rail at the required location in conformity with the design shown on the plans or as ordered.

1.2 Designations will follow the classifications listed in 563.1.2.

### Materials

2.1 Materials shall conform to 563.2.

2.2 The material requirements of 606 shall apply for W-beam guardrail, thrie-beam guardrail, or tubular thrie-beam guardrail.

## SECTION 566

### Construction Requirements

3.1 Fabrication and construction shall comply with the pertinent provisions of 563.3 and 606.3.

### Method of Measurement

4.1 Bridge approach rail, of the type specified, will not be measured, but shall be the linear foot (linear meter) final pay quantity in accordance with 109.11 for bridge approach rail required as shown on the plans.

### Basis of Payment

5.1 Bridge approach rail, of the type specified, is a final pay quantity item and will be paid for at the Contract unit price per linear foot (linear meter) complete in place in accordance with 109.11.

### Pay items and units

565.12	Bridge Approach Rail, ST(F)	Linear Foot (Linear Meter)
565.22	Bridge Approach Rail, T2(F)	Linear Foot (Linear Meter)
565.23	Bridge Approach Rail T3 (F)	Linear Foot (Linear Meter)
565.24	Bridge Approach Rail, T4(F)	Linear Foot (Linear Meter)
565.72	Bridge Approach Rail F, (2-bar) (F)	Linear Foot (Linear Meter)
565.73	Bridge Approach Rail F, (3-bar) (F)	Linear Foot (Linear Meter)
565.81	Rehabilitation of Bridge Approach Rail(F)	Linear Foot (Linear Meter)

## SECTION 566 -- ELASTOMERIC JOINT SEAL

### Description

1.1 This work shall consist of furnishing and installing all required elastomeric compression joint seals extruded to the size, shape, and dimensional tolerances shown on the plans. All surfaces receiving the elastomeric joint seal must be smooth and uniform so as to provide a watertight joint. Designs other than those shown, having similar wall thicknesses and dimensional tolerances and which meet all other requirements of this specification will be considered, but must be approved.

### Materials

#### 2.1 Elastomeric Joint Seal.

2.1.1 The joint seal shall be elastomeric material conforming to AASHTO M 220 meeting the configuration as shown on the plans and shall be a products as included on the Qualified Products List. Each seal shall be furnished full length. Splices in the length of an individual seal will not be permitted unless the splices are made at the plant by the manufacturer of the seal with the approval of the Department.

2.1.2 The elastomeric material shall be identified with the production date, manufacturer's name or trademark, and the lot number.

**2.2** Lubricant-adhesive shall be a one-part, moisture-curing polyurethane and aromatic hydrocarbon solvent mixture with the following physical properties:

Average weight	8 lb/gal ± 10 % (1 kg/L ± 10 %)
Solids content by weight, (min.)	65 percent
Adhesive to remain fluid from	5 to 120 °F (-15° to 50 °C)
Film strength, min. (ASTM D 412)	2,000 psi (13.8 MPa)
Elongation	250 percent

**2.2.1** Each lot of adhesive shall be delivered in containers plainly marked with the manufacturer’s name or trademark and shall be accompanied by the manufacturer’s affidavit attesting conformance with the specification.

**Construction Requirements**

**3.1** The seal shall be installed during that part of the day when the joint opening is nearest its maximum.

**3.2** Joint and seal surfaces shall be clean and dry at the time of installation.

**3.3** The lubricant-adhesive shall be applied and the seal installed in accordance with the manufacturer’s recommended procedure. Except for such cutting as may be provided for on the plans, cutting, twisting, roll-over, or folding of the seal will not be permitted.

**3.4** The seal shall be inserted into the joint with tools that will not injure the material and will place the seal at the proper level in the joint. The seal shall be installed in the joint without stretching. Field splices will not be permitted.

**3.4.1** The depth of setting the seal below the joint surface is critical to its performance. Variation of more than 1/16 in (1.5 mm) high to 1 /8 in (3 mm) low from the setting height indicated on the plans will require resetting.

**Method of Measurement**

**4.1** Elastomeric joint, of the size specified, will not be measured, but shall be the linear foot (linear meter) final pay quantities in accordance with 109.11 for elastomeric joint seals required as shown on the plans. When more than one size is included in the Contract, separate item numbers will be used for each separate size.

**Basis of Payment**

**5.1** Elastomeric joint, of the size specified, is a final pay quantity item and will be paid for at the Contract unit price per linear foot (linear meter) complete in place in accordance with 109.11.

**Pay item and unit:**

566.	Elastomeric Joint Seal (F)	Linear Foot (Linear Meter)
------	----------------------------	----------------------------

## SECTION 568

### *SECTION 568 -- STRUCTURAL TIMBER*

#### **Description**

**1.1** This work shall consist of furnishing, fabricating, preparing, assembling, and erecting structural lumber and timber including the specified paint, preservative, metal parts, and hardware required in conformity with the details shown on the plans or ordered, excluding only those metal parts designated for payment under, or subsidiary to, another item.

#### **Materials**

**2.1** Structural lumber and timber shall consist of the species and grade shown on the plans or ordered, graded according to ASTM D 245.

**2.1.1** Round timber for framed bents and bearing piles shall conform to 510.2.1.1.

**2.2 Timber treatment.** Preservative materials, type and method of treatment, and minimum net retention of preservatives shall conform to the requirements of AASHTO M 133 or as shown on the plans.

**2.2.1** Wood to be painted after treatment shall be treated with a water-borne preservative.

**2.3** Structural shapes, including rods and plates, shall be of structural steel conforming to AASHTO M 183/M 183M (ASTM A 36/A 36M).

**2.4** Castings shall be cast steel or gray iron, as specified.

**2.4.1** Steel castings shall conform to AASHTO M 192/M 192M. Unless otherwise specified, all steel castings shall be Class 485 (70).

**2.4.2** Gray iron castings shall conform to AASHTO M 105 (ASTM A 48). Unless otherwise specified, all gray iron castings shall be Class 30.

#### **2.5 Hardware.**

**2.5.1** Bolts and dowels shall be medium steel. Washers shall be ogee, gray or malleable iron castings, or shall be cut from medium steel.

**2.5.2** Machine bolts shall have square heads and nuts unless otherwise specified. Nails shall be cut or round wire of standard form. Spikes shall be cut spikes, wire spikes, or boat spikes, as specified.

**2.5.3** Unless otherwise specified, except for malleable iron connectors, all hardware, including nails, spikes, bolts, dowels, washers, and lag screws shall be galvanized in conformance with AASHTO M 232 (ASTM A 153) or cadmium plated in conformance with AASHTO M 299 (ASTM B 696).

**2.6** Paint when required shall be as specified and shall conform to 708.

## Construction Requirements

### 3.1 Treatment and Inspection.

**3.1.1** Framing and boring of treated timbers shall be done before the treatment is applied, except for such timbers subject to variations due to field conditions, as indicated on the plans or directed.

**3.1.2** The Contractor shall give ample notice to the Engineer of the beginning of the treatment at the plant so that inspection may be provided. The Contractor shall furnish all facilities for the inspection of material and its treatment. Inspection at the plant is intended as a means of facilitating the work and avoiding error, and it shall be understood that it will not relieve the Contractor of any responsibility in regard to any imperfect material or workmanship and the necessity for replacing the same. The acceptance of any material by the Engineer shall not be a bar to its subsequent rejection if found defective. Rejected materials shall be replaced promptly by the Contractor.

**3.1.3** All work of erection shall be subject to the approval of the Engineer, who shall be given all facilities required for a thorough inspection of workmanship. Material and workmanship not previously inspected will be inspected after it is delivered at the site of the work.

### 3.2 Handling and Storage.

**3.2.1** Loading, transporting, unloading, and piling of timber or lumber shall be conducted so that it is kept clean and free from injury.

**3.2.2** Lumber and timber shall be stored in piles at the site of the work. Untreated material shall be open-stacked and placed on skids so that it is at least 12 in (300 mm) above the ground surface and piled so as to shed water and prevent warping. It shall be protected from the weather by suitable covering when directed. Treated material shall be close-stacked to prevent warping.

**3.2.3** All timber shall be carefully handled. Treated timber shall be so handled that there is no breaking of outer fibers or penetrating of the surfaces with tools. Treated timber shall be handled with rope slings without using cant hooks or similar appliances.

### 3.3 Workmanship.

**3.3.1** All framing shall be true and exact. Nails and spikes shall be driven to set the heads flush with the surface of the wood unless otherwise directed. Hammer marks in wood surfaces will not be permitted. The workmanship on metal parts shall be as specified in 550.3.

**3.3.2** All lumber and timber shall be accurately cut and framed for a close fit with joints bearing evenly over the entire contact surfaces. Mortises shall be true size for their full depths with tenons fitted snugly. Shimming of joints will not be permitted and open joints will not be accepted.

### 3.4 Piles.

**3.4.1** Construction requirements for piles shall conform to the pertinent provisions of 510.3 and the following:

**3.4.2** The piles in any bent shall be selected so that they are of uniform size.

**3.4.3** When a pile is driven out of line, it shall be straightened or replaced before being cut off or braced. Injured piles will not be accepted. Shimming on tops of piles and undue distortion of bracing will not be permitted.

## **SECTION 568**

**3.4.4** After cutting to receive the caps and before the caps are placed, pile heads shall be treated as follows:

**3.4.4.1** The sawed surfaces of treated pile heads shall be covered with 3 applications of an approved preservative meeting the requirements of 2.2.

**3.4.4.2** The sawed surfaces of untreated pile heads shall be thoroughly brush coated with 2 applications of an approved preservative meeting the requirements of 2.2.

**3.4.5** After being treated as specified above, all pile heads shall be covered with sheet metal of the kind specified on the plans. The edges shall be bent down over the sides of the pile and neatly trimmed.

### **3.5 Framed Bents.**

**3.5.1** Mud sills shall be firmly and evenly bedded to solid bearing and tamped into place.

**3.5.2** Sills, posts, and caps shall have true and even bearings on their supports.

**3.5.3** Superstructure stringers shall be sized at bearings and placed so that knots in their edges shall be in the top portions. The joints of stringers, two panels in length, shall be staggered unless otherwise permitted.

**3.5.4** Cross-bridging between stringers shall be as shown or ordered.

**3.5.5** Wheel guards and railings shall be constructed to true line and grade. They shall be placed in sections not less than 12 ft (3.6 m) in length unless otherwise shown or permitted.

**3.5.6** Trusses shall show no irregularities of line when completed. Chords shall be straight and true from end to end in horizontal projection. They shall show a smooth curve through panel joints conforming to the required camber in vertical projection.

### **3.6 Connections.**

**3.6.1** Connections shall be of the types shown or ordered.

### **3.7 Painting.**

**3.7.1** Rails, rail posts, and other portions of the timber work shown or ordered to be painted shall be given three coats of approved paint. Metal parts, except hardware, shall be given one coat of approved shop paint before erection and two coats of approved field paint after erection.

## **Method of Measurement**

**4.1** Structural timber will not be measured, but shall be the thousand foot board measure (MBM) (cubic meter) final pay quantity in accordance with 109.11 for structural timber required as shown on the plans.

## **Basis of Payment**

**5.1** Structural timber is a final pay quantity item and will be paid for at the Contract unit price per MBM (cubic meter) complete in place in accordance with 109.11.

5.2 When a quantity for metal parts other than hardware is included in the proposal, such metal parts will be paid for as provided on the plans.

5.3 Bearing piles will be paid for under 510.

**Pay item and unit:**

568. Structural Timber (F) MBM (Cubic Meter)

**SECTION 570 -- STONE MASONRY**

**Description**

1.1 This work shall consist of furnishing all materials and constructing masonry of approved stones, laid with or without cement mortar, as shown on the plans or ordered.

**Materials**

2.1 Stone shall be furnished in accordance with Table 1.

**Table 1 - Stone for Stone Masonry**

Stone	Source	Quality	Dress and Cut	Finish	
				Top and Bottom	Vertical Face Joints
Ashlar	approved quarry having the required quantity	compact, hard and practically non-absorbent; texture and color as indicated on plans or ordered	to exact dimensions	fine	fine
Squared	approved quarry having the required quantity	compact, hard and practically non-absorbent; texture and color as indicated on plans or ordered	roughly squared and to approximate dimensions	rough for at least 12 in (300 mm) depth	rough for at least 9 in (225 mm) depth
Rubble	field, quarry, or rock excavation	approved, sound, clean, and free from structural defects	unsquared, roughly dressed	---	---

**2.1.1 Ashlar and Squared Stone.**

2.1.1.1 Stones shall have their edges pitched to a true line with tops and bottoms parallel and cut to lie on their natural beds. The bottom beds shall be the full size of the stone, and hollow beds or overhanging tops will not be permitted.

## **SECTION 570**

**2.1.1.2** When specified as random or broken-ranged, stone shall have vertical joints unless otherwise indicated on the plans.

**2.1.1.3** Size of stone shall be as indicated on the plans.

**2.1.1.4** Surface finish shall be as shown on the plans in accordance with the following schedule:

- (a) Smooth finished: surfaces in which the variations from the pitch line do not exceed 1/16 in (1.5 mm).
- (b) Fine finished: surfaces in which the variations from the pitch line do not exceed 1/4 in (6 mm).
- (c) Rough finished: surfaces in which the variations from the pitch line do not exceed 1/2 in (12 mm).
- (d) Scabbled: surfaces in which the variations from the pitch line do not exceed 3/4 in (20 mm).
- (e) Rock-faced: surfaces on which there are no tool marks and which have irregular projection beyond the pitch line of not more than 1-1/4 in (30 mm).
- (f) Weather-faced: surfaces which have been exposed to the weather for sufficient time to become weather beaten in appearance.
- (g) Seam-faced: surfaces which are formed by seams in the natural ledge before stone is quarried.

**2.1.1.5** All stone shall be so finished that no holes or portions of holes will show on surfaces which will be exposed in the finished work.

**2.2** Cement mortar shall conform to 707.

**2.3** Stone masonry anchors shall be of the shapes and dimensions shown on the plans. The minimum ultimate tensile strength shall be 42,000 psi (290 MPa). Anchors shall be zinc-coated (galvanized) in accordance with ASTM A 653/A 653M, coating designation G 90.

### **Construction Requirements**

#### **3.1 Classification.**

**3.1.1** Stone masonry shall be classified by pattern: ranged, broken ranged, or random.

- (a) Ranged masonry shall be laid up in regular courses of uniform height throughout their entire lengths. When the height of courses is varied, it shall be regularly diminished from bottom to top masonry.
- (b) Broken-ranged masonry shall be laid up with courses not continuous throughout their entire lengths.
- (c) Random masonry shall be laid up without courses.

**3.1.2** Stone masonry shall be classified by type of stone and thickness of joints, in accordance with Table 2.

#### **3.2 Laying Stone.**

**3.2.1** All shaping and dressing of stone shall be done before it is placed.

**3.2.2** When required, the Contractor shall submit details of falsework or centering for approval.

**3.2.3** No stone in broken-ranged or random work shall be laid in a structure until at least 50 percent of the amount required for the structure has been delivered at the site.

**3.2.4** Stone shall be carefully set without jarring stone already laid and shall be handled with a lewis or other suitable device which will not mar the stone. Rolling or turning of stone on masonry already in place will not be permitted.

**Table 2 - Stone Masonry Classification**

Class of Masonry	Type of Stone	Joint Material	Max. Thickness inches (mm)
Ashlar	Ashlar	Cement mortar	1/2 (12)
Mortar Squared Stone	Squared	Cement mortar	1 (25)
Dry Squared Stone	Squared	Dry (closely and lightly pinned)	----
Mortar Rubble	Rubble	Cement mortar	1-1/2 (38)
Dry Rubble	Rubble	Dry (closely and lightly pinned)	----
Copings	Squared (Sawn Finish)	Cement mortar	1/2 (12)

**3.2.5** Stone to be laid in cement mortar shall be thoroughly cleaned before being set, and the bed to receive it shall be well cleaned. The thickness of all joints and beds shall be uniform throughout. Spalls shall not be used as pinner in mortar beds or joints. When any stone is disturbed or mortar joint broken, the stone shall be taken up, and after all mortar has been cleaned from the stone, bed, and joints, it shall be reset in fresh mortar.

**3.2.6** All stones shall be well bedded with the face joints properly pointed before the mortar has set, unless otherwise permitted. When permitted, joints to be pointed after mortar has set shall be raked out to a depth of 2 in (50 mm) before mortar has set and when pointed, shall be moistened and filled with mortar well driven in. All pointing shall be finished with an approved pointing tool to form the type of joint indicated on the plans or ordered.

**3.2.7** The masonry shall be kept wet during the pointing and in hot or dry weather shall be protected from the sun and kept wet for a period of 3 days after completion unless otherwise permitted or ordered. The exposed surfaces of the stones shall not be smeared with mortar. The joints shall be wiped free of loose mortar. Stone shall not be set when containing frost or during freezing weather unless permitted. When permission is granted, the masonry shall be protected in the same manner as concrete in 520.3.7 except that liquid curing compound shall not be used, and the masonry temperature shall be controlled as provided in 520.3.7.4.7.

### **3.3 Bond.**

**3.3.1** Stretchers shall have a depth of bed of not less than 1-1/2 times their height. They shall have a length not less than their height, nor less than 3 ft (1.0 m), nor more than 3-1/2 times their height, unless otherwise indicated on the plans.

**3.3.2** Headers shall have a length of 1-1/2 times their height and shall extend entirely through masonry having a thickness of 4 ft (1.2 m) or less. In masonry having a thickness greater than 4 ft (1.2 m), the depth of headers shall not be less than 2-1/2 times their height when the course is 18 in (460 mm) or less in height, and not less than 4 ft (1.2 m) in courses of greater height. Headers shall hold into the heart of the wall the same size shown on the face, bonding not less than 12 in (300 mm) with the core or backing. Headers shall be placed over stretchers equally dividing the spaces between headers of adjoining courses with no joints coming immediately over or under headers. Headers shall be spaced not

## **SECTION 570**

more than 8 ft (2.4 m) apart, and there shall be at least 1 header to every 2 stretchers unless otherwise indicated on the plans.

**3.4 Copings.** Stone for copings shall be selected. Copings shall be as shown on the plans.

**3.5 Cores and backing.** Cores or backing shall be of stone or concrete masonry as indicated on the plans.

**3.5.1** Stone backing shall be laid as specified for face stone, with headers interlocking with face headers when the thickness of the masonry permits. Stone in backing or cores shall break joints with the face stone and bond not less than 12 in (300 mm) with the face stone and with each other. Stone backing or cores shall be carried up with face stone and at least 50 percent of the stone shall be of the same size and character as the face stone and shall have parallel ends. When stone is laid in cement mortar, the beds shall be full and shall not exceed 1 in (25 mm) in thickness, and the joints shall be completely filled and shall not exceed 4 in (100 mm) in thickness.

**3.5.2** Concrete backing or cores shall be of the class shown on the plans and as specified in 520. The concrete shall be so worked and compacted that all spaces around stones are completely filled and an adequate bond with the stone is secured. Construction joints in the concrete, required by intermittent placing, shall be located not less than 6 in (150 mm) below the top bed of any course of the stone facing. The concrete shall be so placed that the stone masonry facing is not disturbed.

**3.6 Metal dowels and cramps.** Dowels and cramps shall be of the material, size, and shape, and at the locations indicated on the plans or as ordered. Holes for dowels or cramps shall be drilled in the stones before they are placed unless otherwise permitted. Cramps shall be countersunk flush with the top of the stone in which they are set. This work shall be subsidiary.

**3.7 Culvert headwalls and retaining walls.** In addition to applicable construction requirements, unless otherwise specified on the plans or in the special provisions, culvert headwalls and retaining walls to be constructed of mortar rubble masonry or dry rubble masonry shall conform to the following requirements: At least 75 percent of the stone shall be larger than 6 by 9 by 12 in (150 by 225 by 300 mm). No dressing, finishing, or coursing will be required. The stone shall be set without disturbing stone already in place. Stone to be laid in mortar shall be clean and moist and shall be placed on a full mortar bed. The stones shall be bonded in a workmanlike manner.

**3.8 Weepers.** Unless otherwise indicated on the plans, the Contractor shall furnish and place 4 in (100 mm) weepers in all closed abutments and retaining walls. These weepers shall be approximately 10 ft (3 m) apart and placed at the elevation which will best drain backfill. French drains of stone or coarse gravel shall be placed adjacent to the fill face of such walls and at such elevations as will permit drainage to and outletting into the weepers.

**3.9 Stone Masonry Arches.**

**3.9.1** Masonry for rings shall be ashlar or mortar squared stone unless otherwise indicated on the plans. Voussoirs shall be full size and shall have a bond of not less than the depth of the stones. Their beds shall be dressed to bring them to radial planes and to permit them to rest properly on the centering. The inside faces of stone backing or spandrel walls and extrados shall be given a finishing coat of 1:2-1/2 cement mortar trowelled smooth, and waterproofed as indicated on the plans.

**3.9.2** Masonry in arch rings shall be placed in such a manner as to load the ring uniformly about the center or as indicated on the plans.

**Method of Measurement**

**4.1** Stone masonry, of the class specified, except coping and resetting masonry wall will not be measured, but shall be the cubic yard (cubic meter) final pay quantity in accordance with 109.11 for stone masonry required as shown on the plans.

**4.2** Stone coping will not be measured, but shall be the linear foot (linear meter) final pay quantity in accordance with 109.11 for stone coping required as shown on the plans.

**4.3** Resetting masonry wall will be measured by the cubic yard (cubic meter), to the nearest 0.1 of a cubic yard (cubic meter).

**Basis of Payment**

**5.1** Stone masonry, of the class specified, except coping and resetting masonry wall,, are final pay quantity items and will be paid for at the Contract unit price per cubic yard (cubic meter) complete in place in accordance with 109.11, with the exception that masonry steps including the parapet walls will be paid for at 1.5 times the Contract unit price per cubic yard (cubic meter) for the class specified.

**5.2** Stone coping is a final pay quantity item and will be paid for at the Contract unit price per linear foot (linear meter) complete in place in accordance with 109.11.

**5.3** The accepted quantity of resetting masonry wall will be paid for at the Contract unit price per cubic yard (cubic meter) complete in place.

**Pay items and units:**

570.1	Ashlar Masonry (F)	Cubic Yard (Cubic Meter)
570.2	Mortar Squared Stone Masonry (F)	Cubic Yard (Cubic Meter)
570.3	Dry Squared Stone Masonry (F)	Cubic Yard (Cubic Meter)
570.4	Mortar Rubble Masonry (F)	Cubic Yard (Cubic Meter)
570.5	Dry Rubble Masonry (F)	Cubic Yard (Cubic Meter)
570.6	Stone Coping (F)	Linear Foot (Linear Meter)
570.9	Resetting Masonry Wall	Cubic Yard (Cubic Meter)

**SECTION 572 -- STONE WALL**

**Description**

**1.1** This work shall consist of reconstructing stone walls where shown on the plans or as ordered.

**Materials**

**2.1** Stone from the existing stone wall shall be utilized to reconstruct the wall at the specified location.

**2.1.1** Any special stone features such as lintels, gate posts, copings, markers, etc. shall be retained for resetting.

## **SECTION 572**

**2.2** Any added stone shall conform to the type used in the original wall.

**2.3** Gravel for surface preparation shall meet the requirements of 209.

### **Construction Requirements**

**3.1** The reconstructed stone wall shall match the existing wall as closely as possible.

**3.1.1** The Contractor shall, by photographs and measurements acceptable to the Engineer, record the width, height and configuration of the existing wall prior to removal. These photographs and measurements along with the prevailing width, height and configuration shall be used to guide the reconstruction of the wall. These records shall be made at intervals of not more than 500 ft (150 m) and at locations where characteristics of the wall change. The photographs shall become the property of the Department at the end of the project.

**3.1.2** When existing wall sections designated for reconstruction are in such disrepair that the original wall configuration cannot be determined, these sections shall be rebuilt to match abutting wall segments.

**3.2** The stone wall reconstruction shall be supervised by a person with experience in dry masonry construction.

**3.3** Care shall be taken to keep weathered faces exposed.

**3.4** The Contractor shall retain all stone from existing wall for reuse. Additional stones that may be necessary shall be blended with the existing stones in order to reproduce the appearance of the existing wall.

**3.5** The Contractor shall carefully replace chinking, blocking, bond stones and headers, as appropriate to the original style of wall, to ensure the maximum stability of the wall.

**3.6** The Contractor shall carefully duplicate special features of the original wall, such as lintels, gate posts, openings, copings, markers, etc.

**3.7** The ground surface shall be prepared by removing brush, vegetation, topsoil and unsuitable material. The area shall be rough graded to obtain a reasonably firm and level surface.

### **Method of Measurement**

**4.1** Reconstructing stone walls will be measured by the linear foot (linear meter), to the nearest 1 foot (0.5 meter), along the center line of the reconstructed wall.

**4.2** Clearing and grubbing will be measured as provided in 201.

**4.3** Gravel required for surface preparation will be measured by the cubic yard (cubic meter), complete in place. Limits of gravel will be as shown on the plans, or as ordered.

### **Basis of Payment**

**5.1** The accepted quantity of reconstructed wall will be paid for at the Contract unit price per linear foot (linear meter) complete in place.

**5.1.1** Any additional stone required to complete the reconstruction will be subsidiary.

## SECTION 572

**5.1.2** Reconstruction of special features as defined in 3.6 will be subsidiary.

**5.1.3** Photographs and measurement records of the existing wall will be subsidiary.

**5.2** Ground surface preparation will be subsidiary.

**5.2.1** When special site preparation such as clearing and grubbing or gravel base courses are ordered, this work will be paid under appropriate items of the Contract. If appropriate items are not included in the Contract, this work will be paid as provided in 109.04.

### **Pay items and units:**

572.1	Reconstructing Stone Wall, One Stone Wide	Linear Foot (Linear Meter)
572.2	Reconstructing Stone Wall, Multiple Stones Wide	Linear Foot (Linear Meter)
572.3	Reconstructing Stone Wall, Double Faced with Loose Fill	Linear Foot (Linear Meter)

FOR INFORMATION  
GENERAL CONFIGURATION OF STONE WALLS

---

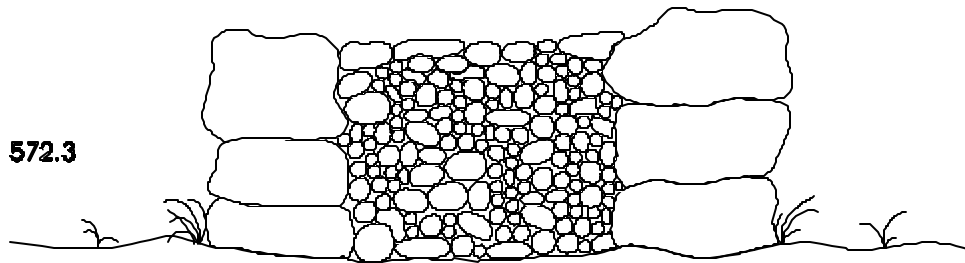
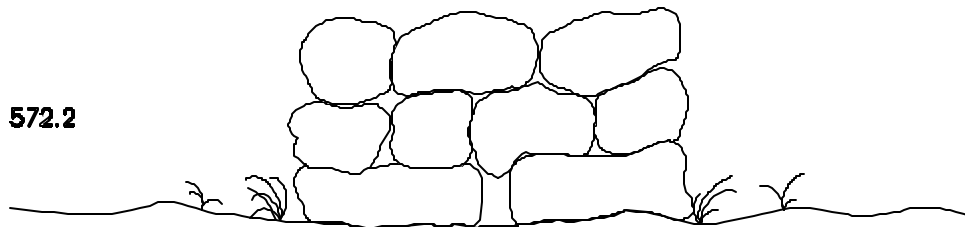
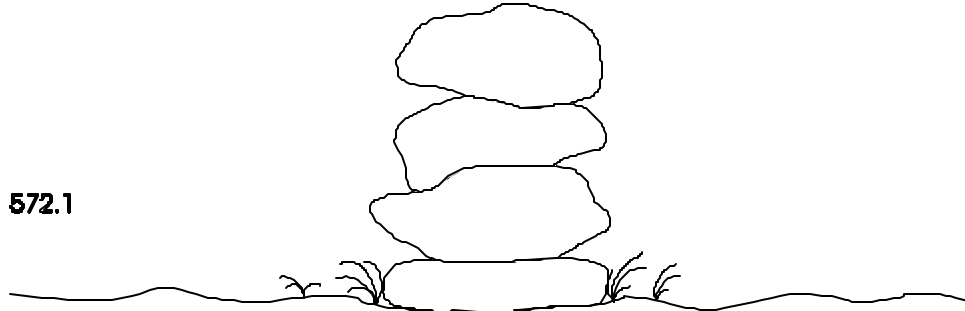

**NOTE:** DEPICTIONS ARE FOR DESCRIPTION OF THE ITEMS AND NOT INTENDED TO BE USED FOR CONSTRUCTION DETAIL.

**SECTION 582 -- SLOPE PAVING****Description**

**1.1** This work shall consist of a paved area of concrete as specified on a blanket of sand constructed at the locations shown on the plans or ordered.

**Materials**

**2.1** Concrete shall be Class A and conform to 520. The slump shall be 2 to 3 in (50 to 75 mm).

**2.2** Welded wire fabric shall conform to AASHTO M 55/M 55M (ASTM A 185) with a minimum gauge and spacing to be as shown in accordance with the Concrete Reinforcing Steel Institute.

**2.3** Sand shall conform to 304.2.3.

**2.4** Granular backfill shall conform to 209.2.1.2.

**2.5** Prefomed Joint filler shall conform to AASHTO M 213.

**Construction Requirements**

**3.1** The Contractor shall set forms so that the concrete slabs as detailed are parallel to the centerline of the structure. Forms shall allow for the outer 5 ft (1.5 m) to slope 1 in (25 mm). Concrete slab panel widths may vary from 5 to 30 ft (1.5 to 9 m) provided sections are of equal size and shall conform to the slopes as shown. No abrupt plan changes of horizontal joints will be permitted unless approved by the Engineer. Unless otherwise permitted, the Contractor shall pour alternating concrete panels to help reduce shrinkage cracking.

**3.2** Granular backfill and sand shall be placed and compacted to assure a proper bed, as detailed.

**3.3** Welded wire fabric, of the type specified, shall be placed as detailed. Other wire fabric patterns may be substituted provided an equal quantity of steel is supplied for each square foot (square meter) of area.

**3.3.1** The fabric shall be placed at least 3 in (75 mm) from all concrete surfaces and need not be continuous through any joints, but must be lapped with a minimum edge lap of 3 in (75 mm) or 1/2 mesh size and a minimum end lap of 6 in (150 mm) or 1 mesh size.

**3.4** Prefomed joint filler shall be placed along abutment or pier faces as detailed or ordered.

**3.5** After curing in accordance with 520.3.10.1, the entire surface shall be treated with two coats of Item 537, unless otherwise ordered.

**SECTION 582**

**SLOPE PAVING WITH CONCRETE DETAILS**

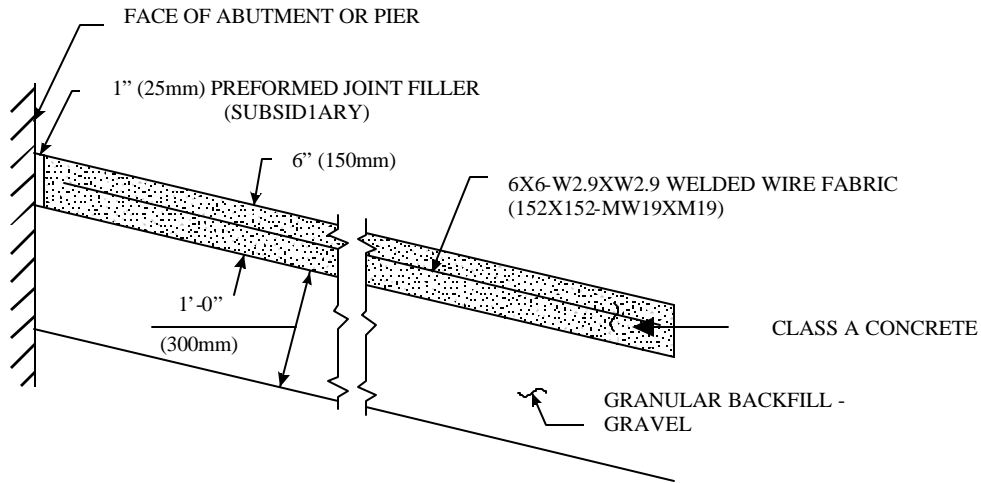

**DETAIL FOR TYPICAL 4: 1 SLOPE OR LESS**

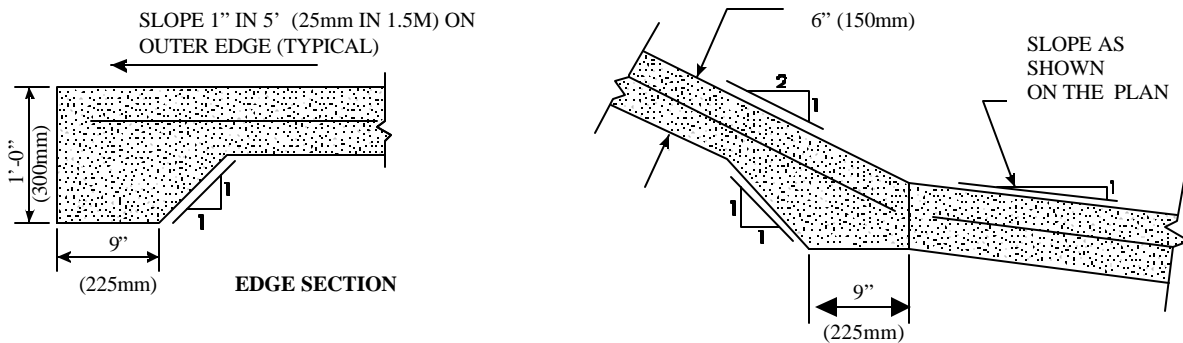
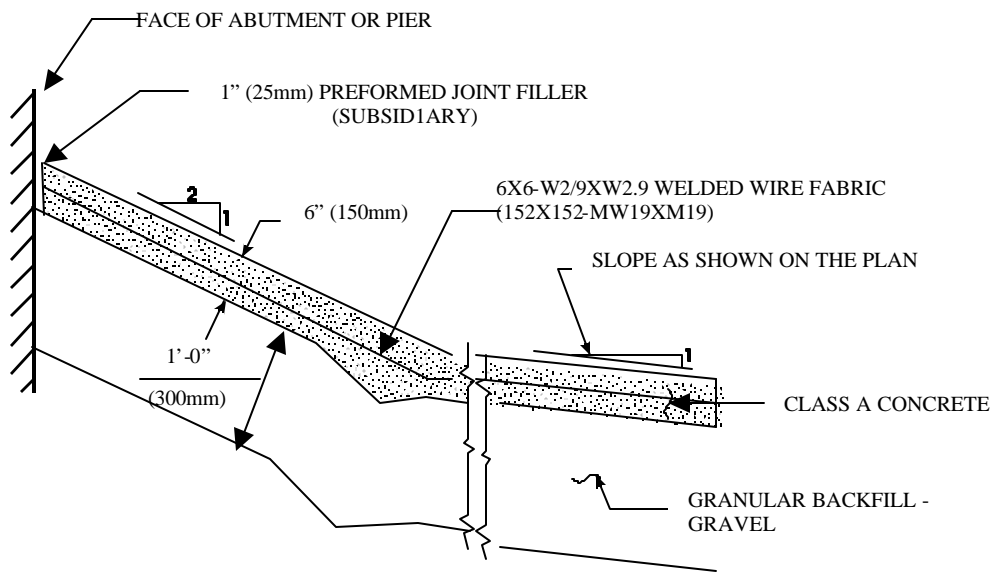

**DETAIL FOR TYPICAL 6: 1 OR 4: 1 SLOPE TO A 2: 1 SLOPE**

### Method of Measurement

**4.1** Slope paving, of the type specified, will not be measured, but shall be the square foot (square meter) final pay quantities in accordance with 109.11 for slope paving required as shown on the plans. Reinforcing fabric, sand bed and preformed joint filler will not be measured.

### Basis of Payment

**5.1** Slope paving, of the type specified, is a final pay quantity item and will be paid for at the Contract unit price per square foot (square meter) complete in place in accordance with 109.11. Excavation, sand, paving material, reinforcing fabric and joint filler shall be subsidiary to slope paving of the type specified.

**5.1.1** Granular backfill will be paid for under 209.1.

**5.1.2** Concrete sealer will be paid for under 537.

#### Pay item and unit:

582.1	Slope Paving with Concrete (F)	Square Yard (Square Meter)
582.5	Slope Paving with Granite Slabs (F)	Square Yard (Square Meter)

## SECTION 583 -- RIPRAP

### Description

**1.1** This work shall consist of a protective covering of stone constructed at the locations shown on the plans or ordered.

### Materials

**2.1** Field stone, quarry stone, or rock fragments used for riprap shall be sound, of approved quality, and free from structural defects. These stones shall have approximately rectangular shapes with one reasonably flat side for the top surface and shall have minimum dimensions and volumes as listed below:

**2.1.1 Riprap A, 1 ft (300 mm) thick.** Seventy-five percent of the stones shall have a minimum volume of 2 ft<sup>3</sup> (0.06 m<sup>3</sup>); the remainder shall have a minimum volume of 1/2 ft<sup>3</sup> (0.015 m<sup>3</sup>).

**2.1.2 Riprap B, 1-1/2 ft (460 mm) thick.** Seventy-five percent of the stones shall have a minimum volume of 8 ft<sup>3</sup> (0.2 m<sup>3</sup>).

**2.1.3 Riprap C, 2 ft (600 mm) thick.** Seventy-five percent of the stones shall have a minimum volume of 12 ft<sup>3</sup> (0.3 m<sup>3</sup>).

**2.1.4 Riprap D, 2-1/2 ft (760 mm) thick.** Seventy-five percent of the stones shall have a minimum volume of 18 ft<sup>3</sup> (0.5 m<sup>3</sup>).

**2.2** Gravel blanket material shall conform to 209.2.1.2.

## SECTION 583

### Construction Requirements

**3.1** Riprap stones shall be individually laid upward from the toe of the slope with the larger stones at the toe of the slope. The stones shall be laid with close joints roughly perpendicular to the slope. Open joints shall be filled with spalls.

**3.2** When a gravel blanket is shown or ordered, the gravel shall be placed in layers not exceeding 12 in (300 mm) in depth unless otherwise ordered.

**3.3** The finished surface shall be reasonably uniform in appearance, approximately parallel to and within 6 in (150 mm) of the lines and grades shown or ordered.

### Method of Measurement

**4.1** Riprap will be measured by the cubic yard (cubic meter) and computed to the nearest 0.1 of a cubic yard (cubic meter) by multiplying the actual area of the accepted and approved riprap by the nominal depth as shown or ordered.

### Basis of Payment

**5.1** The accepted quantity of riprap of the type specified will be paid for at the Contract unit price per cubic yard (cubic meter) complete in place.

**5.2** Gravel blanket material specified or ordered will be paid for under 209.

**5.3** The accepted quantity of excavation required for placing riprap and for placing any underlying gravel blanket will be paid for under the item of excavation being performed. Excavation above refers only to excavation of original ground or to material ordered removed not shown on the plans.

**5.4** Free borrow will not be required to replace the accepted quantity of stone obtained from the excavation. However, when the plans do not call for borrow, but the quantity of material removed from excavation for use under this item requires the Contractor to furnish borrow to complete the work, such borrow will be subsidiary.

### Pay items and units:

583.1	Riprap A	Cubic Yard (Cubic Meter)
583.2	Riprap B	Cubic Yard (Cubic Meter)
583.3	Riprap C	Cubic Yard (Cubic Meter)
583.4	Riprap D	Cubic Yard (Cubic Meter)

## SECTION 585 -- STONE FILL

### Description

**1.1** This work shall consist of furnishing and placing a dense stone fill at the locations shown on the plans or ordered.

### Materials

**2.1** Stone for stone fill shall be approved quarry stone, or broken rock of a hard, sound, and durable quality. The stones and spalls shall be so graded as to produce a dense fill with a minimum of voids.

**2.1.1** Class A stone shall be irregular in shape with approximately 50 percent of the mass having a minimum volume of 12 ft<sup>3</sup> (0.3 m<sup>3</sup>), approximately 30 percent of the mass ranging between 3 and 12 ft<sup>3</sup> (0.08 and 0.3 m<sup>3</sup>), approximately 10 percent of the mass ranging between 1 and 3 ft<sup>3</sup> (0.03 and 0.08 m<sup>3</sup>), and the remainder of the mass composed of spalls.

**2.1.2** Class B stone shall be irregular in shape with approximately 50 percent of the mass having a minimum volume of 3 ft<sup>3</sup> (0.08 m<sup>3</sup>), approximately 40 percent of the mass ranging between 1 and 3 ft<sup>3</sup> (0.03 and 0.08 m<sup>3</sup>), and the remainder of the mass composed of spalls.

**2.1.3** Class C stone shall consist of clean, durable fragments of ledge rock of uniform quality, reasonably free from thin or elongated pieces. The stone shall be made from rock which is free from topsoil and other organic material. The stone shall be graded as follows:

Sieve Size	Percentage by Weight Passing
12 in (300 mm)	100
4 in (100 mm)	50 - 90
1-1/2 in (37.5 mm)	0 - 30
3/4 in (19.0 mm)	0 - 10

**2.1.4** Class D stone shall conform to 520.2.2.3, Table 3 - Coarse Aggregate, Standard Stone Size No. 467.

**2.1.5** Spalls for filling voids shall be stones or broken rock ranging downward from a maximum size of 1 ft<sup>3</sup> (0.03 m<sup>3</sup>).

**2.2** Gravel blanket material shall conform to 209.2.1.2.

**2.3** Geotextile shall conform to 593.

### Construction Requirements

**3.1** Stones and spalls for stone fill shall be deposited and graded to eliminate voids and obtain a dense mass throughout the course. The spalls shall be tamped into place using an equipment bucket or other approved method.

**3.1.1** When stone fill is placed on a slope, the stones shall be deposited in such a manner as to not unnecessarily dislodge the underlying material.

**3.1.2** When stone fill is placed on a geotextile, it shall be deposited in such a manner so as to maintain the integrity of the geotextile.

**3.2** When gravel blanket is shown or ordered, the gravel shall be placed in layers not exceeding 12 in (300 mm) in depth unless otherwise ordered.

**3.3** The completed surface shall approximate the lines and grades shown or ordered. When ordered, stone placed over 1 ft (300 mm) outside or above such lines and grades shall be removed.

## SECTION 587

3.4 Stone fill (Bridge) shall be placed within the limits shown on the plans.

### Method of Measurement

4.1 Stone fill will be measured by the cubic yard (cubic meter) and in accordance with 109.01.

### Basis of Payment

5.1 The accepted quantity of stone fill of the class specified will be paid for at the contract unit price per cubic yard (cubic meter) complete in place.

5.2 Gravel blanket material specified or ordered will be paid for under 209.

5.3 Geotextile specified or ordered will be paid for under 593.

5.4 The accepted quantity of excavation required for placing stone fill and for placing any underlying gravel blanket will be paid for under the item of excavation being performed. Excavation above refers only to excavation of original ground or to material ordered removed not shown on the plans.

5.5 Free borrow will not be required to replace the accepted quantity of stone obtained from the excavation. However, when the plans do not call for borrow, but the quantity of material removed from excavation for use under this item requires the Contractor to furnish borrow to complete the work, such borrow will be subsidiary.

### Pay items and units:

585.1	Stone Fill, Class A	Cubic Yard (Cubic Meter)
585.2	Stone Fill, Class B	Cubic Yard (Cubic Meter)
585.21	Stone Fill, Class B (Bridge)	Cubic Yard (Cubic Meter)
585.3	Stone Fill, Class C	Cubic Yard (Cubic Meter)
585.4	Stone Fill, Class D	Cubic Yard (Cubic Meter)

## SECTION 586 -- PLACING EXCAVATED ROCK

### Description

1.1 This work shall consist of placing excavated rock in designated locations and to the thickness or shape shown on the plans or ordered.

### Materials

2.1 The material shall be approved from excavation within the project or an off-site source.

### Construction Requirements

3.1 The rock shall be close-packed and keyed together to be stable. The surface shall conform approximately to the specified lines and grades. Where ditches and channels are being lined or covered, the rock shall be left in such a position that the required waterway area is obtained. Rejected rock remaining outside of the lines and grades shown or ordered shall be removed. Fine grading will not be required.

### Method of Measurement

4.1 Excavated rock placed under this item will be measured by the cubic yard (cubic meter).

### Basis of Payment

5.1 The accepted quantity of excavated rock placed will be paid for at the Contract unit price per cubic yard (cubic meter) complete in place.

5.2 The accepted quantity of excavation required for placing excavated rock will be paid for under the item of excavation being performed. Excavation above refers only to excavation of original ground or to material ordered removed not shown on the plans.

### Pay item and unit:

586	Placing Excavated Rock	Cubic Yard (Cubic Meter)
586.1	Placing Excavated Rock in Stockpiles	Cubic Yard (Cubic Meter)
586.2	Placing Excavated Rock for Channel Protection	Cubic Yard (Cubic Meter)
586.3	Placing Excavated Rock for Slope Protection	Cubic Yard (Cubic Meter)
586.4	Placing Excavated Rock for Rock Lined Ditches	Cubic Yard (Cubic Meter)

## SECTION 587 -- KEYED STONE FILL

### Description

1.1 This work shall consist of furnishing and placing keyed stone fill to provide protection from erosion at locations shown on the plans or ordered.

### Materials

2.1 Stone shall be hard, durable, angular in shape, resistant to weathering and shall meet the following requirements. Neither breadth nor thickness of a single stone shall be less than one-third its length. Rounded stones or boulders will not be accepted without permission. The material shall not contain overburden, soil, shale or stone with shale seams, or organic material.

2.1.1 The sources from which the stone is obtained shall be selected well in advance of the time when the material will be required in the work. The acceptability of the stone will be determined by previous use records or by tests as the Engineer determines to be appropriate. If testing is required, suitable samples of stone shall be furnished by the Contractor and taken in the presence of the Engineer sufficiently in advance of the time when the placing is expected to begin. The approval of some stone from a particular source shall not be construed as constituting the approval of all stone taken from that source.

2.1.2 Stone shall be graded with approximately 30 percent of the mass ranging between 2.5 and 5 ft<sup>3</sup> (0.07 and 0.14 m<sup>3</sup>), approximately 45 percent of the mass ranging between 1 and 2.5 ft<sup>3</sup> (0.03 and 0.07 m<sup>3</sup>), approximately 15 percent of the mass ranging between 0.2 and 1 ft<sup>3</sup> (0.006 and 0.03 m<sup>3</sup>), and the remaining stones being less than 0.2 ft<sup>3</sup> (0.006 m<sup>3</sup>).

## SECTION 587

**2.1.3** Visual control of gradation will be by one of two methods: (1) loading from an approved stockpile at the quarry site or (2) comparing with a sample truckload at the revetment site. If a stockpile cannot be provided, the Contractor shall provide, at a location satisfactory to the Engineer and in close proximity to the project, a mass rock sample of at least 5 tons (4.5 metric tons) meeting the gradation for keyed stone fill. This sample will be used as a frequent reference for judging the gradation of the material supplied. Any difference of opinion between the Engineer and the Contractor shall be resolved by dumping and checking the gradation of truck loads of stone as ordered. Mechanical equipment, a sorting site, and labor needed to assist in checking gradation shall be provided by the Contractor.

**2.2** Gravel blanket material shall conform to 209.2.1.2.

### Construction Requirements

**3.1 Preparation of slopes.** Slopes to be protected shall be free of brush, trees, stumps, and other organic material and shall be dressed to a smooth surface. All soft or spongy material shall be removed to the depth shown on the plans or as directed and replaced with approved material. The density of such filled areas shall be as specified in 203.3.8. A toe trench shall be dug when shown on the plans and maintained until the stone is placed.

**3.2 Gravel blanket construction.** The filter blanket shall be placed on the prepared area to the full specified thickness in one operation, using methods which will not cause segregation of particle sizes within the layer. The surface of the finished layer shall be reasonably even and free from mounds or windrows.

**3.3 Erosion control.** It will be the Contractor's responsibility to protect embankments and excavated slopes from erosion by concurrent construction of the blanket and the stone.

**3.4 Placing stone.** The stone fill shall be placed in a manner which will produce a reasonably well-graded mass. The fill shall be placed to its full depth in one operation and in such a manner as to avoid displacing the underlying material. Placing of materials by end dumping on the slopes or by other methods likely to cause segregation will not be permitted.

**3.4.1** The larger stones shall be well distributed and the entire mass of stone shall conform approximately to the gradation specified. All stones shall be so placed and distributed that there will be no large accumulations of either the larger or smaller sizes. To accomplish this, all material shall be uniformly placed with a clam-shell, orange-peel bucket, skip, or similar approved device which will contain the material to its final destination. Materials shall not be dropped. The bucket shall not be opened until it has been lowered to the slope on which the material is being placed. The surface of the course shall be made smooth and uniform. Hand placing or rearranging of individual stones by mechanical equipment may be required to the extent necessary to secure the uniformity of gradation and surface specified.

**3.5 Compacting and keying.** After the material has been placed, it shall be compacted and keyed into place by impacting the exposed surface from a height of 3 to 4 ft (0.9 to 1.2 m) with a piece of armor plating approximately 4 by 5 ft (1.2 by 1.5 m) in size and weighing approximately 5,000 lb (2270 kg) or some other approved means which will produce a reasonably tight surface. If stones have been placed below water, the surface of the fill shall be smoothed by dragging the plate across it as necessary.

**3.5.1** Plating will not be required on stone fill within 10 ft (3 m) of any pier, abutment, or retaining wall.

**Method of Measurement**

**4.1** Keyed stone fill will be measured by the cubic yard (cubic meter).

**4.1.1** If the Engineer determines that in-place measurement is impracticable, the quantity for payment will be determined by loose measure in the hauling vehicle on the basis that 1 cubic yard (cubic meter), vehicle measure, is equivalent to 0.7 cubic yard (cubic meter) in place.

**Basis of Payment**

**5.1** The accepted quantity of keyed stone fill will be paid for at the Contract unit price per cubic yard (cubic meter) complete in place.

**5.1.1** Only when stone is examined in accordance with 2.1.3 and examination proves the gradation to be acceptable will payment be made for the examination process as extra work.

**5.2** Gravel blanket material specified or ordered will be paid for under 209.1.

**5.3** The accepted quantity of excavation required for placing keyed stone fill and for placing any underlying gravel blanket will be paid for under the item of excavation being performed. Excavation above refers only to excavation of original ground or to material ordered removed not shown on the plans.

**5.4** Free borrow will not be required to replace the accepted quantity of stone obtained from the excavation. However, when the plans do not call for borrow but the quantity of material removed from excavation for use under this item requires the Contractor to furnish borrow to complete the work, such borrow will be subsidiary.

**Pay item and unit:**

587.1 Keyed Stone Fill            Cubic Yard (Cubic Meter)

## SECTION 591

### *SECTION 591 -- STRUCTURAL PLATE PIPES, PIPE-ARCHES, AND ARCHES*

#### **Description**

**1.1** This work shall consist of furnishing and installing steel structural plate pipes, pipe-arches, or arches, of the size and type specified, at the location shown on the plans or ordered.

**1.1.1** Structural plate pipe as mill fabricated shall be elliptical.

#### **Materials**

**2.1** Materials and design of plates and metal bearings shall be as specified on the plans or in the AASHTO "Standard Specifications for Highway Bridges" unless otherwise provided hereinafter.

**2.2** Plates and fasteners shall conform to AASHTO M 167/M 167M.

**2.2.1** Dimensions, including the thickness of plates, shall be as shown on the plans.

**2.3 Elliptical requirements for pipe.** Pipe under the item of structural plate pipe shall be fabricated elliptically so as to increase the vertical diameter 5 percent and decrease the horizontal diameter 5 percent. These dimensions shall be subject to manufacturing tolerances.

**2.4** Backfill shall conform to 209.2.1.2.

#### **Construction Requirements**

##### **3.1 General.**

**3.1.1** The Contractor shall provide for the temporary diversion of water in order to permit the installation of the structure in a reasonably dry trench unless otherwise permitted.

**3.1.2** Fabrication and erection of structural plate structures shall be as specified in the AASHTO "Standard Specifications for Highway Bridges" unless otherwise specified hereinafter.

**3.1.3** Where soft or other unsuitable material is encountered, all of such unsuitable material shall be removed for the depth shown or ordered. See Figure 1-a.

**3.1.4** Where bedrock or other incompressible material is encountered, it shall be removed to a minimum of 1 ft (300 mm) below the flow line. See Figure 1-b.

**3.1.5** Granular backfill or other approved material shall be used to backfill the spaces left by the excavation of material removed in accordance with 3.1.3 and 3.1.4. The material shall be uniformly compacted by the use of lightweight construction equipment.

##### **3.2 Bedding of Pipe and Pipe -Arches.**

**3.2.1** The structure shall be placed at the designated location on a prepared foundation of granular backfill so that the flow line of the structure will conform to the required grade. Pipe or pipe-arch structures shall be set on a uniformly compacted bed of fine granular material 1 ft (300 mm) deep, or as ordered, below the bottom of the structure. The bed shall extend under the structure and at least 1 ft (300 mm) beyond each side of the span. See Figure 1-c.

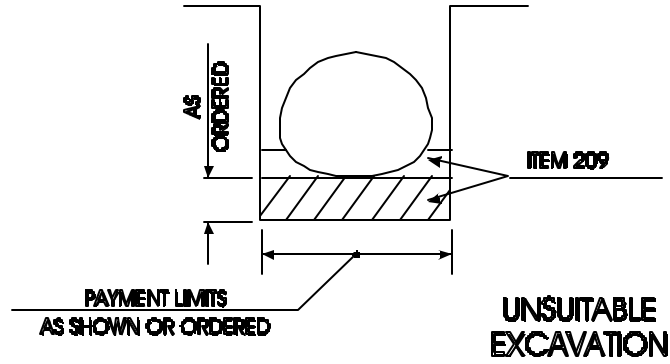

1 - a

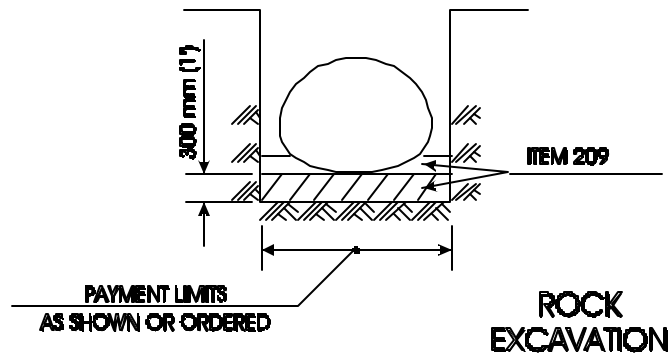

1 - b

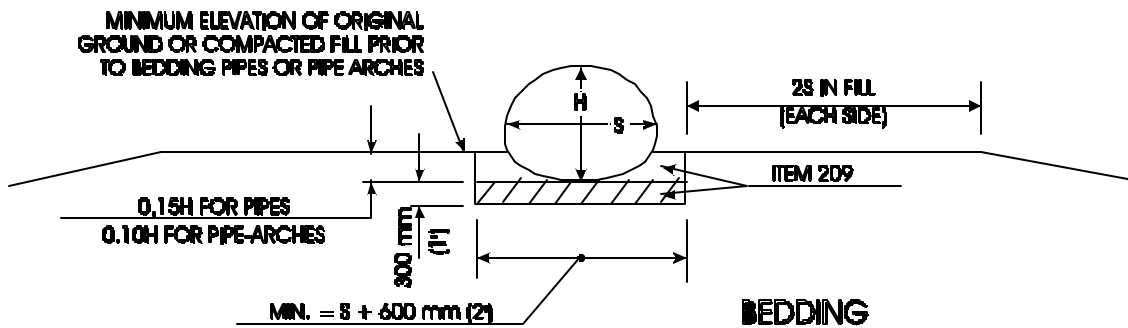

1 - c

FIGURE 1 - STRUCTURAL PLATE PIPE AND PIPE-ARCH DETAILS

## **SECTION 591**

**3.2.2** The granular backfill shall be carefully shaped by means of a template to fit the lower exterior of the structure, forming a trench equal in depth to at least 10 percent of the height in the case of a pipe-arch and 15 percent of the height in the case of a pipe. Care shall be taken to maintain the height of the edges of the bedding. Reasonable latitude will be permitted to allow for the field bolting of both circumferential and longitudinal seams of plates that are in the area of the shaped trench. When the top of the granular backfill is above the natural ground, fill for lateral support shall be constructed on each side of the granular backfill for a distance of approximately 2 times the span of the pipe or pipe-arch. See Figure I-c.

### **3.3 Arch Substructure.**

**3.3.1** The substructure for the arch shall be constructed as shown on the plans.

### **3.4 Structure Assembly.**

**3.4.1** The plates for the structure shall be assembled according to the manufacturer's assembly instructions and the plans.

**3.4.2** Pipe or pipe-arch structures may be assembled in their final location or partially or completely assembled elsewhere and then placed on the prepared foundation.

**3.4.3** Arches shall be erected in place upon the prepared substructure.

**3.4.4** The structure shall be assembled by partial bolting with the plate location and sequence of plates as shown on the Fabricator's drawings. Complete bolting and hand tightening shall follow the assembly no closer than two or three plate rings. Final tightening shall be carried out progressively and uniformly. Whenever possible, final tightening shall be completed by working from the outside and inside of the structure at the same time with the operation repeated as required, making sure that all bolts are tight. With pipe, the final tightening shall start at the bottom seams and work progressively to the top seams on each side.

**3.4.5** When assembling structures intended to be used as pedestrian or animal passes, all bolts shall be placed with bolt heads on the inside of the structure.

**3.4.6** Pipes shall normally be installed with the longer axis vertical.

**3.4.7** Anchor bolts shall be installed when and as shown on the plans.

**3.4.8** After erection of an arch and before backfilling is started, the groove of the metal bearing channel shall be filled with asphalt filler to the level of the top of the concrete.

**3.4.9** When completed, the structure shall be true to the required alignment and grade and properly placed as to the center line of the road.

### **3.5 Backfilling Structural Plate Pipe and Pipe -Arch.**

**3.5.1** All backfill material adjacent to a pipe or pipe-arch shall be approved compactible soil or granular fill material and shall not contain stones retained on a 3 in (75 mm) screen. This soil shall extend to a height of at least 1 ft (300 mm) above the top of the structure and the width shall fill the trench or in fills extend for a width on each side of the structure equal to twice the diameter or 12 ft (3.6 m) whichever is less, with the slopes normal to the structure not steeper than 6:1.

**3.5.2** This material shall be uniformly compacted at near optimum moisture content, in layers not exceeding 6 in (150 mm) in compacted thickness, by pneumatic tampers, vibratory compactors, or other approved means. Care shall be exercised to thoroughly compact the backfill under the haunches of the pipe or pipe-arch and to insure that the backfill soil is in intimate contact with the side of the structure. The backfill shall be brought up evenly on both sides of the structure along the full length installed. Fill at the sides may be compacted by rolling or operating heavy equipment parallel with the structure, provided care is taken to avoid displacement or injury. Material in the vicinity of pipes or pipe-arches shall be compacted to not less than 95 percent of AASHTO T 99, Method C.

**3.5.3** The Contractor shall place a protecting cover of earth or other approved material over the structure before allowing equipment or traffic to pass over it. The protective cover shall be of a thickness to prevent overstress and damage to the pipe as specified by the pipe manufacturer.

**3.6 Arch Backfill.**

**3.6.1** When backfilling an arch before headwalls are placed, the first material shall be placed in the form of ramps constructed on both sides of the arch, at right angles to the axis of the arch and midway of the ends. These two ramps shall be as narrow as practicable, consistent with thorough compaction, and shall be brought up uniformly on both sides of the arch until the ramps meet and material is placed at least 1 ft (300 mm) above the top of the arch. After the ramps have been joined, the remainder of the backfill shall be placed and compacted, widening the ramps uniformly along both sides and toward each end of the arch to avoid springing the arch out of shape.

**3.6.2** If the headwalls are built before the arch is backfilled, the filling material shall first be placed adjacent to one headwall until the top of the arch is reached, after which the fill shall be dumped from the top of the arch toward the other headwall, with care being taken to deposit the material evenly on both sides of the arch.

**3.6.3** In all cases, the filling material shall be thoroughly but not excessively tamped.

**3.6.4** Puddling the backfill will not be permitted.

**3.6.5** Arches shall be protected as required in 3.5.3.

**3.7 Workmanship.**

**3.7.1** It is the intent of these specifications that in addition to compliance with the details of construction, the completed structure shall show careful and finished workmanship in all particulars.

**3.7.2** Structures on which the spelter coating has been bruised or broken, either in the shop or in shipping, or which show defective workmanship, shall be rejected or repaired as directed. This requirement applies not only to the individual plates but to the shipment of any contract item as a whole.

**3.7.2.1** The following defects are specified as constituting poor workmanship, and the presence of any or all of them in any individual culvert plate or in general in any shipment shall constitute sufficient cause for rejection:

- (a) Uneven laps
- (b) Variation from a straight center line
- (c) Ragged edges
- (d) Loose or unevenly lined or spaced bolts

## SECTION 591

- (e) Illegible brand
- (f) Bruised, scaled, or broken spelter coating
- (g) Dents or bends in the metal itself

**3.7.2.2** Damaged spelter coating may be repaired by thoroughly wire brushing the damaged area and painting it with 2 coats of zinc-rich primer, 708-Appendix A.

### Method of Measurement

**4.1** Structural plate pipes, pipe-arches and arches will not be measured, but shall be the pound (kilogram) final pay quantity in accordance with 109.11 for the structural plate structure required as shown on the plans. When more than one structure is specified in the Contract, separate item numbers will be used for each separate and complete structure.

### Basis of Payment

**5.1** Structural plate pipes, pipe-arches and arches are final pay quantity items and will be paid for at the Contract unit price per pound (kilogram) complete in place in accordance with 109.11.

**5.2** Excavation will be paid for under 504 regardless of the span.

**5.3** Granular backfill below the flow line or as shown on the plans will be paid for under 209.

**5.4** Paving of invert, if required, will be paid for under the hand method of 403.

**5.5** Concrete for arch substructure will be paid for under 520.

### Pay items and units:

591.1	Structural Plate Pipe (F)	Pound (Kilogram)
591.2	Structural Plate Pipe-Arch (F)	Pound (Kilogram)
591.3	Structural Plate Arch (F)	Pound (Kilogram)

## SECTION 593 -- GEOTEXTILE

### Description

**1.1** This work shall consist of furnishing and installing geotextile fabric as shown on the plans or as ordered, including any labor and materials needed to anchor, splice, or repair the geotextile.

### Materials

**2.1 General.** Geotextile shall be a product tested under the AASHTO National Transportation Product Evaluation Program (NTPEP) and included on the Qualified Products List for the Application, Strength Class, and Structure specified.

**2.1.1** All geotextile properties referenced in the specifications and certified by the Contractor, with the exception of Apparent Opening Size (AOS), shall be considered minimum average roll values in the

weaker principal direction (i.e., the average test results for any sampled roll in a lot shall meet or exceed the minimum values specified). Values for AOS shall represent maximum average roll values.

**2.1.2** Fibers used in the manufacture of geotextiles, and threads used in joining geotextiles by sewing, shall meet the requirements of Section 3.1 and Section A1.4.1 of AASHTO M 288.

**2.1.3** Geotextile shall exhibit an ultraviolet stability (retained strength) of at least 50% after 500 hours of exposure, measured in accordance with ASTM D 4355.

**2.2 Application.** Following are the basic Applications of geotextile included under this specification. Applications are described according to their most common use(s) and may not include every function for which a geotextile is specified.

**2.2.1** Application 1 – Subsurface Drainage. Geotextile for this Application consists of fabric placed against a soil to allow for long-term passage of water into a subsurface drain system while retaining the in situ soil.

**2.2.2** Application 2 – Separation. Geotextile for this Application consists of fabric placed to prevent mixing of in situ or subgrade soil with aggregate cover materials.

**2.2.3** Application 3 – Stabilization. Geotextile for this Application consists of fabric placed in wet, saturated conditions to provide the coincident functions of separation and filtration. This Application may also be specified for geotextiles used to provide the function of reinforcement.

**2.2.4** Application 4 – Permanent Erosion Control. Geotextile for this Application consists of fabric placed below riprap or other armor systems to prevent soil loss and/or instability of the erosion control system.

**2.3 Strength Class.** Following are the basic Strength Classes of geotextile included under this specification:

**2.3.1** Class 1, Class 2, and Class 3. Geotextile specified as Class 1 (high strength), Class 2 (medium strength), or Class 3 (low strength) shall meet the applicable requirements of AASHTO M 288, Table 1, including sewn seam strength when sewn seams are used. A higher strength geotextile may be substituted for a lower strength geotextile provided all other specification requirements are met.

**2.3.2** Class 0. Geotextile specified as Class 0 (extra high strength) shall meet the following minimum requirements:

<b>Geotextile Property</b>	<b>Test Method</b>	<b>Property Requirement</b> [ lb. (N)]
Grab Tensile Strength	ASTM D 4632	375 (1670)
Sewn Seam Strength	ASTM D 4632	335 (1500)
Tear Strength	ASTM D 4533	135 (600)
Puncture Strength	ASTM D 4833	225 (1000)

## SECTION 593

**2.4 Structure.** The contract Item Number for geotextile includes a designation for Structure that defines the basic composition of the fabric. Geotextile shall conform to the specified structure as identified by the Item Number.

**2.5 Permittivity and Apparent Opening Size (AOS).** Geotextile shall meet the following requirements for permittivity and Apparent Opening Size (AOS):

Application	Required Geotextile Property	
	Permittivity per ASTM D 4491 (sec <sup>-1</sup> )	Apparent Opening Size (AOS) per ASTM D 4751 (mm)
1 - Subsurface Drainage	0.70 min.	0.22 max.
2 - Separation	0.05 min.	0.43 max.
3 - Stabilization	0.05 min.	0.43 max.
4 - Permanent Erosion Control	0.70 min.	0.22 max.

**2.6** Each roll shall be clearly labeled so as to easily identify the product in the field. The label shall include as a minimum the manufacturer's name, product name and number, and the Contract Item name and number.

**2.7 Staples or Pins.** Staples or pins required to hold the geotextile prior to placing overlying materials shall be those prescribed by the geotextile manufacturer.

### Construction Requirements

**3.1 Protection of Geotextile.** To prevent damage to the fabric, the Contractor shall exercise necessary care while transporting, storing, and installing the fabric. Prior to installation, the fabric shall be protected from weather, direct sunlight or other ultra-violet exposure, and from dust, mud, dirt, debris, and other elements which may affect its performance. Fabric that is torn, punctured, or otherwise damaged shall not be placed. After placement, fabric shall be covered within 5 days. Traffic or construction equipment shall not be permitted directly on the geotextile.

**3.2 Placement of Geotextile and Overlying Materials.** The geotextile and overlying materials shall be placed in accordance with the plans, the manufacturer's requirements, and the following:

**3.2.1. General.** Prior to placement of the fabric, the site shall be prepared to provide a smooth surface which is free from debris, obstructions, and depressions which could result in gaps, tears, or punctures in the fabric during cover operations.

**3.2.1.1** Successive sheets placed above water shall be overlapped by a minimum of 18 inches (0.5 meter). Sheets placed below water shall be sewn or overlapped by a minimum of 3 feet (1 meter). Larger overlaps may be called for on the plans or required by the Engineer in soft soil conditions or if gaps between adjacent sheets occur during placement of overlying material. Pins or staples may be used to anchor the fabric as directed by the Engineer.

**3.2.2 Subsurface Drainage.** Trench excavation shall be done in accordance with details shown on the plans. In all instances, excavation shall be done in such a way so as to prevent large voids from occurring in the sides and bottom of the trench.

**3.2.2.1** The geotextile shall be placed loosely with no wrinkles or folds, and with no void spaces between the geotextile and the ground surface. Successive sheets shall be shingled such that the upstream sheet is placed over the downstream sheet.

**3.2.2.2** Placement of drainage aggregate shall proceed immediately following placement of the geotextile. The geotextile shall be covered with a minimum of 12 inches (0.3 meter) of loosely placed aggregate prior to compaction. If a collector pipe is to be installed in the trench, a bedding layer of drainage aggregate shall be placed below the pipe, with the remainder of the aggregate placed to the minimum required construction depth.

**3.2.2.3** After placing the drainage aggregate, the geotextile shall be folded over the top of the aggregate in a manner that produces the overlap shown on the plans. In no case shall the minimum overlap be less than 12 inches (0.3 meter).

**3.2.3 Separation/Stabilization.** The installation site shall be prepared by clearing, grubbing, and removal of vegetation and topsoil. The site shall be excavated or filled to the proper grade as shown on the plans or as ordered. The Engineer may order that soft spots and unsuitable areas identified during site preparation or subsequent proof rolling be excavated, backfilled, and compacted with suitable materials.

**3.2.3.1** The geotextile shall be laid smooth without wrinkles or folds on the prepared subgrade, except that it may be folded or cut to conform to curves. Joints and overlaps shall be in the direction shown on the plans or as ordered by the Engineer. The folds or overlaps shall be held in place by pins, staples, or piles of fill or rock.

**3.2.3.2** Overlying fill or aggregate materials shall be placed by end dumping onto the geotextile from the edge of the geotextile, or over previously placed materials. Construction vehicles shall not be allowed directly on the geotextile. Materials shall be placed such that at least the minimum specified lift thickness is between the geotextile and equipment tires or tracks at all times. Turning of vehicles shall not be allowed on the first lift above the geotextile.

**3.2.3.2.1** On very soft subgrades, the fill or aggregate shall be spread to the proper lift thickness as soon as possible after dumping to minimize the potential of localized subgrade failure due to concentrated loading.

**3.2.3.2.2** In stabilization applications, vibratory compaction equipment on the initial lift of fill or aggregate material may be prohibited by the Engineer to prevent damage to the geotextile.

**3.2.3.3** Placement procedures that result in instability or damage to the geotextile shall be modified to eliminate further damage. The Engineer may order remedial measures such as increasing the initial lift thickness or decreasing equipment loads.

**3.2.3.4** Geotextile placed below temporary fills shall be completely removed immediately after the fill is removed. Geotextile salvaged from use under temporary fills shall not be used for any permanent application in the project unless approved by the Engineer.

**3.2.4 Permanent Erosion Control.** The geotextile shall be placed in intimate contact with the soils without wrinkles or folds, and anchored on a smooth graded surface approved by the Engineer. The

## SECTION 593

geotextile shall be placed in such a manner that placement of the overlying materials will not excessively stretch nor tear the geotextile. Anchoring of the terminal ends of the geotextile shall be accomplished through the use of key trenches or aprons at the crest and toe of the slope as shown on the plans.

**3.2.4.1** The geotextile shall be placed with the machine direction (long direction of the roll) parallel to the direction of water flow, which is normally parallel to the slope for erosion control runoff and wave action, and parallel to the stream or channel in the case of stream bank and channel protection. When overlapping, the fabric shall be placed such that the uphill sheet is placed over the downhill sheet, and the upstream sheet is placed over the downstream sheet. In cases where wave action or multidirectional flow is anticipated, all seams perpendicular to the direction of flow shall be sewn.

**3.2.4.2** The armor system placement shall begin at the toe and proceed up the slope. Placement shall take place so as to avoid stretching, puncturing, and tearing of the geotextile. Particles smaller than 1.5 cubic feet (0.04 cubic meter) shall be placed with drop heights less than 3 feet (1 meter). Particles greater than 1.5 cubic feet (0.04 cubic meter) shall be placed with no free fall. Drop heights exceeding the distance specified above may be allowed by the Engineer if field tests demonstrate that larger drop heights will not result in damage to the fabric. In no case shall stones be rolled or pushed onto the geotextile.

**3.2.4.3** The geotextile and armor materials shall be placed the same day in underwater applications.

**3.2.4.4** Field monitoring shall be performed to verify that the armor system placement does not damage the geotextile. Fabric which is damaged as a result of careless or improper placement of stone, grading techniques, or equipment traffic above the stone shall be repaired or replaced in accordance with 3.3.

**3.3 Repair of Geotextile.** Fabric that is damaged during or after placement shall be replaced or repaired by stitching or patching at the expense of the Contractor. Patches shall be of the same material as the placed geotextile. The patch shall be joined to the existing fabric using overlapped seams as specified above or as directed by the Engineer.

**3.3.1** The Contractor shall modify his placement or covering procedures to eliminate further or repeated damage from occurring.

**3.4 Sewn Seams.** Sewn seams, if specified, ordered, or allowed, shall result in a joint at least as strong as the sewn seam strength requirements described in 2.3. Field or factory seaming will be permitted unless otherwise specified. Sewn seams shall be lapped a minimum of 4 inches and double sewn using Stitch Type 401 as depicted in ASTM D 6193. Either a "J" seam (Type SSn-2) or "Butterfly" seam (Type SSd-2) shall be used as shown in Figure 1.

**3.4.1** All seams shall be subject to the approval of the Engineer. Sewn seams shall be positioned on the exposed side of the fabric to allow for inspection and/or repair of the fabricated joint. Seams shall not be positioned as shown in Figure 2.

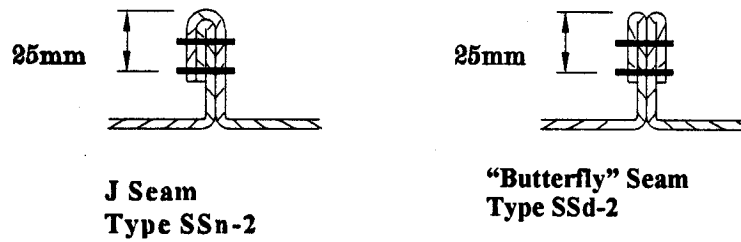

FIGURE 1

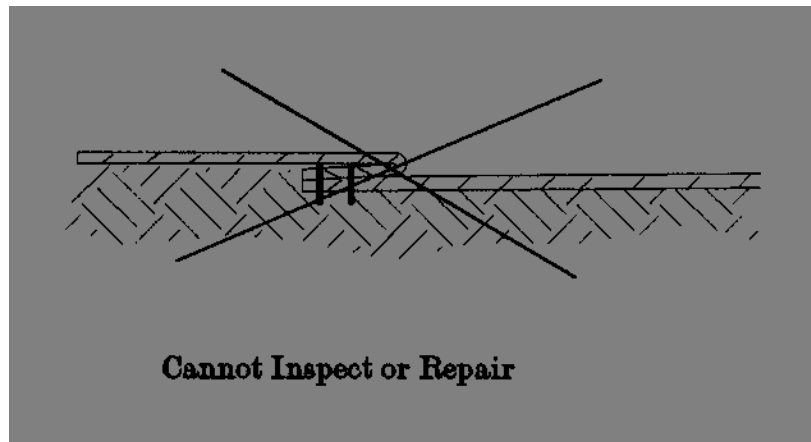

FIGURE 2

#### Method of Measurement

**4.1** Geotextile will be measured by the square yard (square meter) as determined by the actual surface measurements of the covered area. Additional material used for overlaps and repairs will not be measured.

#### Basis of Payment

**5.1** The accepted quantity of geotextile will be paid for at the Contract unit price per square yard (square meter) for the application, strength class, and structure specified, complete in place. The cost of all labor or materials used to anchor, splice, or repair the geotextile is considered subsidiary to the geotextile installation. Removal of temporary geotextile will be considered subsidiary to the geotextile installation.

## SECTION 593

### Pay Item and Unit:

593.A B C

Square Yard (Square Meter)

#### Key:

A= Application

1 = Subsurface Drainage

2 = Separation

3 = Stabilization

4 = Permanent Erosion Control

B = Strength Class

0 = Class 0

1 = Class 1

2 = Class 2

3 = Class 3

C = Structure

0 = Contractor Option

1 = Nonwoven (Default for Application 1 & Application 4)

2 = Monofilament, Woven

3 = Slit Filament, Woven